



21in Mulching/Rear Bagging Lawn Mower

Form No. 3379-755 Rev A

Model No. 10736—Serial No. 314000001 and Up

Operator's Manual



Receive a free side-discharge chute by completing the *Discharge Chute Order Form* when you register your product at www.Lawn-Boy.com! Please allow four to five weeks for delivery.

Introduction

This rotary-blade, walk-behind lawn mower is intended to be used by residential homeowners. It is designed primarily for cutting grass on well-maintained lawns on residential properties. It is not designed for cutting brush or for agricultural uses.

Read this information carefully to learn how to operate and maintain your product properly and to avoid injury and product damage. You are responsible for operating the product properly and safely.

You may contact Lawn-Boy directly at www.Lawn-Boy.com for product and accessory information, help finding a dealer, or to register your product.

Whenever you need service, genuine Lawn-Boy parts, or additional information, contact an Authorized Service Dealer or Lawn-Boy Customer Service and have the model and serial numbers of your product ready. Figure 1 identifies the location of the model and serial numbers on the product. Write the numbers in the space provided.

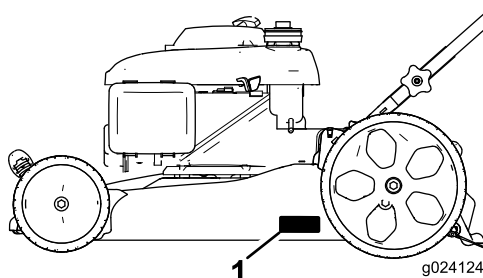

Figure 1

1. Model and serial number plate

Model No. _____
Serial No. _____

This manual identifies potential hazards and has safety messages identified by the safety alert symbol (Figure 2), which signals a hazard that may cause serious injury or death if you do not follow the recommended precautions.



Figure 2

1. Safety alert symbol

This manual uses 2 words to highlight information.

Important calls attention to special mechanical information and **Note** emphasizes general information worthy of special attention.

WARNING

CALIFORNIA Proposition 65 Warning

This product contains a chemical or chemicals known to the State of California to cause cancer, birth defects, or other reproductive harm.

The engine exhaust from this product contains chemicals known to the State of California to cause cancer, birth defects, or other reproductive harm.

Important: This engine is not equipped with a spark arrester muffler. It is a violation of California Public Resource Code Section 4442 to use or operate the engine on any forest-covered, brush-covered, or grass-covered land. Other states or federal areas may have similar laws.

This spark ignition system complies with Canadian ICES-002.

The enclosed *Engine Owner's Manual* is supplied for information regarding the US Environmental Protection



Agency (EPA) and the California Emission Control Regulation of emission systems, maintenance, and warranty. Replacements may be ordered through the engine manufacturer.

Net Torque

The gross or net torque of this engine was laboratory rated by the engine manufacturer in accordance with the Society of Automotive Engineers (SAE) J1940. As configured to meet safety, emission, and operating requirements, the actual engine torque on this class of mower will be significantly lower.

Contents

Introduction	1
General Operation	2
Slope Operation	3
Children	3
Service	3
Safety and Instructional Decals	4
Setup	5
Attaching the Handle	5
Installing the Recoil-starter Rope in the Rope Guide	5
Filling the Engine with Oil	5
Product Overview	6
Operation	7
Attachments/Accessories	7
Filling the Fuel Tank	7
Checking the Engine-oil Level	7
Adjusting the Cutting Height	8
Starting the Engine	8
Stopping the Engine	9
Mulching the Clippings	9
Bagging the Clippings	9
Operating Tips	9
Maintenance	11
Recommended Maintenance Schedule(s)	11
Preparing for Maintenance	12
Servicing the Air Cleaner	12
Changing the Engine Oil	13
Replacing the Blade	13
Cleaning the Underside of the Machine	14
Storage	15
Preparing the Machine for Storage	15
Folding the Handle	15
Removing the Machine from Storage	15

Safety

This machine meets or exceeds the CPSC blade safety requirements for walk-behind rotary lawn mowers.

Read and understand the contents of this manual before you start the engine.

The safety alert symbol (Figure 2) is used to alert you to potential personal injury hazards. Obey all safety messages that follow this symbol to avoid possible injury or death. Improperly using or maintaining this mower could result in injury or death. To reduce this potential, comply with the following safety instructions.

The following instructions have been adapted from the ANSI/OPEI standard B71.1-2003.

This cutting machine is capable of amputating hands and feet and of throwing objects. Failure to observe the following safety instructions could result in serious injury or death.

General Operation

- Read, understand, and follow all instructions on the machine and in the manual(s) before starting.
- Do not put hands or feet near or under the machine. Keep clear of the discharge opening at all times.
- Allow only responsible adults, who are familiar with the instructions, to operate this machine.
- Clear the area of objects such as rocks, wire, toys, etc., which could be thrown by the blade. Stay behind the handle when the engine is running.
- Be sure the area is clear of bystanders before operating. Stop machine if anyone enters the area.
- Do not operate the machine barefooted or while wearing sandals. Always wear substantial footwear.
- Do not pull machine backward unless absolutely necessary. Always look down and behind before and while moving backward.
- Never direct discharged material toward anyone. Avoid discharging material against a wall or obstruction. Material may ricochet back toward the operator. Stop the blade when crossing gravel surfaces.
- Do not operate machine without the entire grass catcher, discharge guard, rear guard, or other safety protective devices in place and working.
- Never leave a running machine unattended.
- Stop the engine and wait until the blade comes to a complete stop before cleaning the machine, removing grass catcher, or unclogging the discharge guard.
- Operate machine only in daylight or good artificial light.
- Do not operate machine while under the influence of alcohol or drugs.
- Never operate the mower in wet grass. Always be sure of your footing; walk; never run.

- Disengage the drive system, if so equipped, before starting the engine.
- If the machine should start to vibrate abnormally, stop the engine and check for the cause immediately. Vibration is generally a warning of trouble.
- Always wear eye protection when operating the machine.
- Lightning can cause severe injury or death. If you see lightning or hear thunder in the area, do not operate the machine; seek shelter.
- See the manufacturer's instructions for proper operation and installation of accessories. Only use accessories approved by the manufacturer.

Slope Operation

Slopes are a major factor related to slip-and-fall accidents, which can result in severe injury. Operation on all slopes require extra caution. If you feel uneasy on a slope, do not mow it.

- Mow across the face of slopes; never up and down. Exercise extreme caution when changing direction on slopes.
- Watch for holes, ruts, bumps, rocks, or other hidden objects. Uneven terrain could cause a slip-and-fall accident. Tall grass can hide obstacles.
- Do not mow on wet grass or excessively steep slopes. Poor footing could cause a slip-and-fall accident.
- Do not mow near drop-offs, ditches, or embankments. You could lose your footing or balance.

Children

Tragic accidents can occur if the operator is not alert to the presence of children. Children are often attracted to the machine and the mowing activity. **Never** assume that children will remain where you last saw them.

- Keep children out of the mowing area and under the watchful care of a responsible adult other than the operator.
- Be alert and turn mower off if a child enters the area.
- Never allow children to operate the machine.
- Use extra care when approaching blind corners, shrubs, trees, or other objects that may block your view of a child.

Service

Safe Handling of Gasoline

To avoid personal injury or property damage, use extreme care in handling gasoline. Gasoline is extremely flammable and the vapors are explosive.

- Extinguish all cigarettes, cigars, pipes, and other sources of ignition.

- Use only an approved gasoline container.
- Never remove the gas cap or add fuel with the engine running. Allow engine to cool before refueling.
- Never refuel the machine indoors.
- Never store the machine or fuel container where there is an open flame, spark, or pilot light, such as on a water heater or on other appliances.
- Never fill containers inside a vehicle or on a truck or trailer bed with a plastic liner. Always place containers on the ground away from your vehicle before filling.
- Remove gas-powered equipment from the truck or trailer and refuel it on the ground. If this is not possible, then refuel such equipment with a portable container rather than from a gasoline dispenser nozzle.
- Keep the nozzle in contact with the rim of the fuel tank or container opening at all times until fueling is complete. Do not use a nozzle lock-open device.
- If fuel is spilled on clothing, change clothing immediately.
- Never overfill fuel tank. Replace the gas cap and tighten it securely.

▲ WARNING

Exhaust contains carbon monoxide, an odorless, deadly poison that can kill you.

Do not run the engine indoors or in an enclosed area.

General Service

- Never operate the machine in a closed area.
- Keep all nuts and bolts tight to be sure the equipment is in safe working condition.
- Never remove or tamper with safety devices. Check their proper operation regularly. Never do anything to interfere with the intended function of a safety device or to reduce the protection provided by a safety device.
- Keep the machine free of grass, leaves, or other debris build-up. Clean up oil or fuel spillage and remove any fuel-soaked debris. Allow the machine to cool before storing it.
- If you strike a foreign object, stop and inspect the machine. Repair, if necessary, before starting.
- Never make any adjustments or repairs with the engine running. Disconnect the spark-plug wire and ground against the engine to prevent unintended starting.
- Check grass catcher components and the discharge guard frequently and replace them with manufacturer's recommended parts, when necessary.
- Mower blades are sharp. Wrap the blade or wear gloves, and use extra caution when servicing them.
- Do not change the engine governor setting or overspeed the engine.

- Maintain or replace safety and instruction labels, as necessary.
- To best protect your investment and maintain optimal performance of your Lawn-Boy equipment, count on Lawn-Boy genuine parts. When it comes to reliability, Lawn-Boy delivers replacement parts designed to the exact engineering specifications of our equipment. For peace of mind, insist on Lawn-Boy genuine parts.

Hauling

- Use care when loading or unloading the machine into a trailer or truck.
- Use full-width ramps for loading the machine into a trailer or truck.
- Tie the machine down securely using straps, chains, cable, or ropes. Both the front and the rear straps should be directed down and outward from the machine.

Safety and Instructional Decals

Important: Safety and instruction decals are located near areas of potential danger. Replace damaged decals.

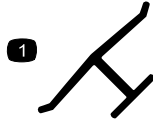

Manufacturer's Mark

1. Indicates that the blade is identified as a part from the original machine manufacturer.



94-8072

CALIFORNIA SPARK ARRESTER WARNING
 Operation of this equipment may create sparks that can start fires around dry vegetation. A spark arrester may be required. The operator should contact local fire agencies for laws or regulations relating to fire prevention requirements. 117-2718

117-2718

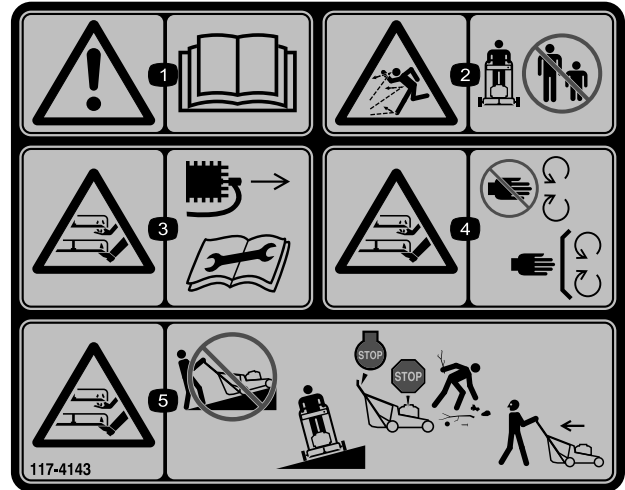

117-4143

1. Warning—read the *Operator's Manual*.
2. Thrown object hazard—keep bystanders a safe distance from the machine.
3. Cutting/dismemberment hazard of hand or foot, mower blade—disconnect the spark-plug wire and read the instructions before servicing or performing maintenance.
4. Cutting/dismemberment hazard of hand or foot, mower blade—stay away from moving parts and keep all guards and shields in place.
5. Cutting/dismemberment hazard of hand or foot, mower blade—do not mow up and down slopes, only mow across; stop the mower and engine, pick up debris before operating; look behind and down when reversing.

Setup

Important: Remove and discard the protective plastic sheet that covers the engine.

Attaching the Handle

⚠ WARNING

Folding or unfolding the handle improperly can damage the cables, causing an unsafe operating condition.

- Do not damage the cables when folding or unfolding the handle.
- If a cable is damaged, contact an Authorized Service Dealer.

1. Remove the handle knobs from the machine housing (Figure 3).

Important: Route the cables to the outside of the handle as you install the handle.

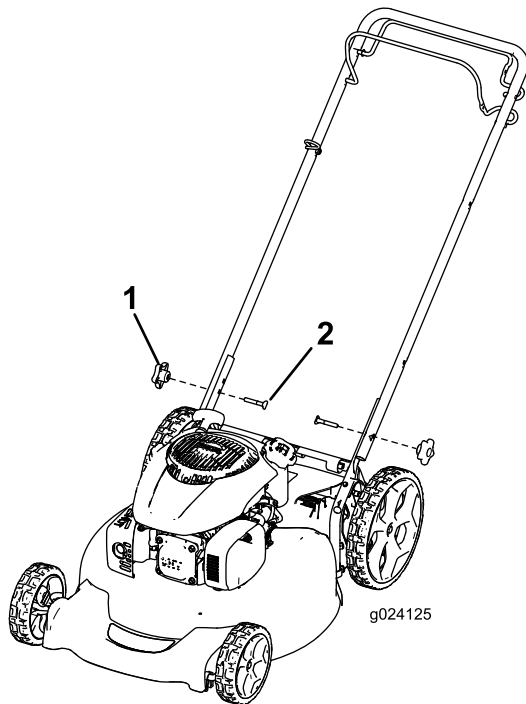

Figure 3

1. Handle knob (2)
2. Bolt (2)

Installing the Recoil-starter Rope in the Rope Guide

Important: To start the engine safely and easily whenever you use the machine, install the recoil-starter rope in the rope guide.

Hold the blade-control bar to the upper handle, and pull the recoil-starter rope through the rope guide on the handle (Figure 4).

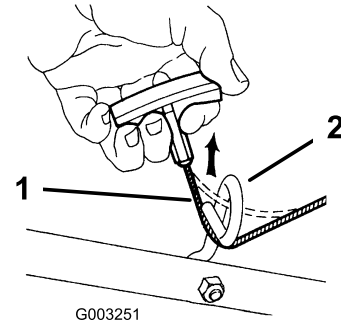

Figure 4

1. Recoil-starter rope
2. Rope guide

Filling the Engine with Oil

Important: Your machine does not come with oil in the engine. Before starting the engine, fill the engine with oil.

1. Move the machine to a level surface.
2. Remove the dipstick (Figure 5) and pour about 3/4 of the crankcase capacity of oil into the oil-fill tube.

Note: Max. fill: 0.55 L (18.6 oz), type: SAE 30 detergent oil with an API service classification of SF, SG, SH, SJ, SL, or higher.

2. Move the handle to the operating position (Figure 3).
3. Install the handle knobs and tighten them firmly by hand.

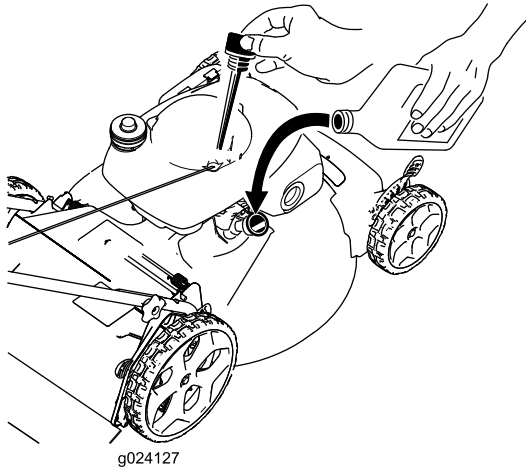
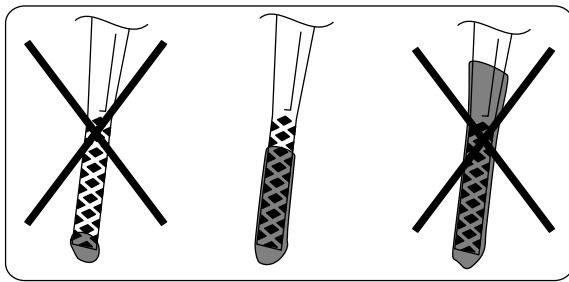

Figure 5

Product Overview

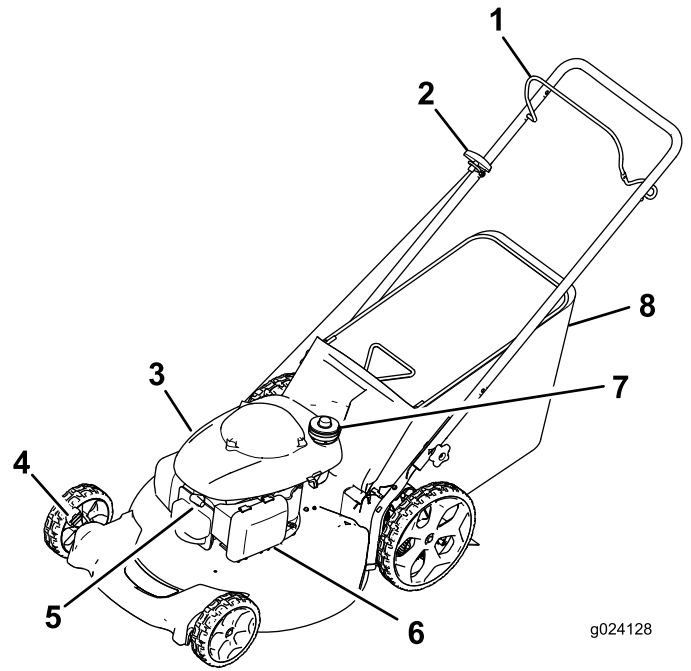

Figure 6

- | | |
|------------------------------------|------------------|
| 1. Blade-control bar | 5. Spark plug |
| 2. Recoil-start handle | 6. Air cleaner |
| 3. Oil fill / Dipstick (not shown) | 7. Fuel-tank cap |
| 4. Cutting-height lever (2) | 8. Grass bag |

3. Wipe off the dipstick end with a clean cloth.
 4. Insert the dipstick into the oil-fill tube, but **do not** screw it in.
 5. Remove the dipstick and read the oil level on the dipstick (Figure 5).
 - If the oil level is low, add a small amount of oil slowly to the oil-fill tube, and then repeat steps 3 through 5 until the oil level on the dipstick is correct.
 - If the oil level is high, drain the excess oil until the oil level on the dipstick is correct. To drain the excess oil, refer to Changing the Engine Oil (page 13).
- Important:** If the oil level in the crankcase is too low or too high and you run the engine, you may damage the engine.
6. Install the dipstick securely.

Important: *Change the engine oil after the first 5 operating hours; change it yearly thereafter. Refer to Changing the Engine Oil (page 13).*

Operation

Attachments/Accessories

A selection of Lawn-Boy approved attachments and accessories is available for use with the machine to enhance and expand its capabilities. Contact your Authorized Service Dealer or Distributor or go to www.Lawn-Boy.com for a list of all approved attachments and accessories.

Filling the Fuel Tank

⚠ DANGER

Gasoline is extremely flammable and explosive. A fire or explosion from gasoline can burn you and others.

- To prevent a static charge from igniting the gasoline, place the container and/or machine directly on the ground before filling, not in a vehicle or on an object.
- Fill the tank outdoors when the engine is cold. Wipe up spills.
- Do not handle gasoline when smoking or around an open flame or sparks.
- Store gasoline in an approved fuel container, out of the reach of children.
- For best results, use only clean, fresh (less than 30 days old), unleaded gasoline with an octane rating of 87 or higher ((R+M)/2 rating method).
- Oxygenated fuel with up to 10% ethanol or 15% MTBE by volume is acceptable.
- **Ethanol:** Gasoline with up to 10% ethanol (gasohol) or 15% MTBE (methyl tertiary butyl ether) by volume is acceptable. Ethanol and MTBE are not the same. Gasoline with 15% ethanol (E15) by volume is not approved for use. **Never use gasoline that contains more than 10% ethanol by volume**, such as E15 (contains 15% ethanol), E20 (contains 20% ethanol), or E85 (contains up to 85% ethanol). Using unapproved gasoline may cause performance problems and/or engine damage which may not be covered under warranty.
- Do not use gasoline containing methanol.
- Do not store fuel either in the fuel tank or in fuel containers over the winter unless a fuel stabilizer is used.
- Do not add oil to gasoline.

Important: To reduce starting problems, add fuel stabilizer to the fuel all season, mixing it with gasoline less than 30 days old.

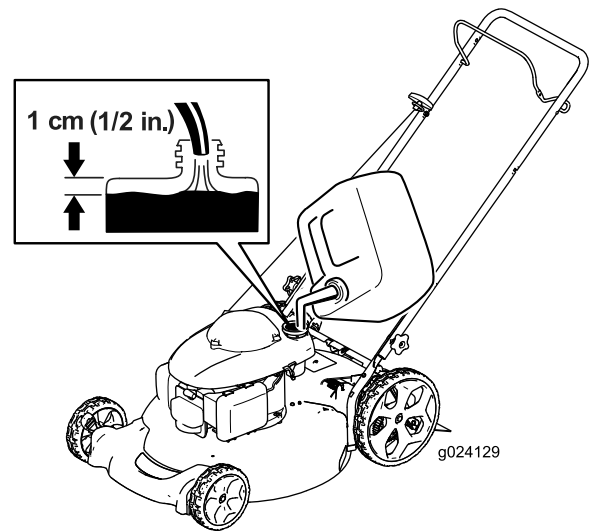

Figure 7

Checking the Engine-oil Level

Service Interval: Before each use or daily

Max. fill: 0.55 L (18.6 oz), type: SAE 30 or SAE 10W-30 detergent oil with an API service classification of SF, SG, SH, SJ, SL, or higher.

1. Move the machine to a level surface.
2. Remove the dipstick (Figure 8).

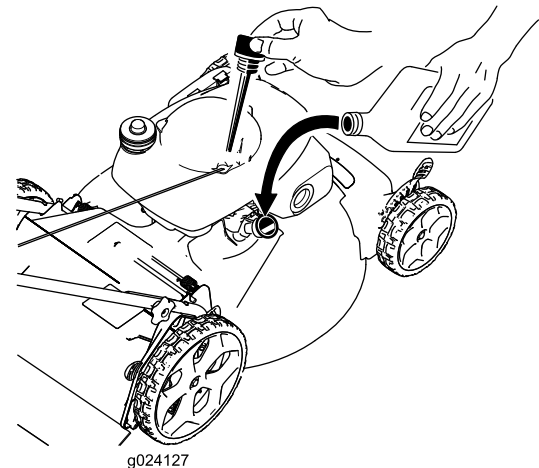
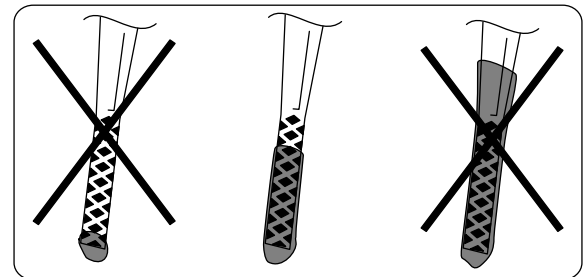

Figure 8

3. Wipe off the dipstick end with a clean cloth.

4. Insert the dipstick into the oil-fill tube, but **do not** screw it in.
 5. Remove the dipstick and read the oil level; refer to Figure 8.
 - If the oil level is low, add a small amount of oil slowly to the oil-fill tube, and then repeat steps 3 through 5 until the oil level on the dipstick is correct.
 - If the oil level is high, drain the excess oil until the oil level on the dipstick is correct. To drain the excess oil, refer to Changing the Engine Oil (page 13).
- Important:** If the oil level in the crankcase is too low or too high and you run the engine, you may damage the engine.
6. Install the dipstick securely.

Important: The cutting height settings are 32 mm (1-1/4 inches); 44 mm (1-3/4 inches); 57 mm (2-1/4 inches); 70 mm (2-3/4 inches); 83 mm (3-1/4 inches); and 95 mm (3-3/4 inches).

Starting the Engine

1. Turn the fuel-valve lever to the On position (Figure 10).

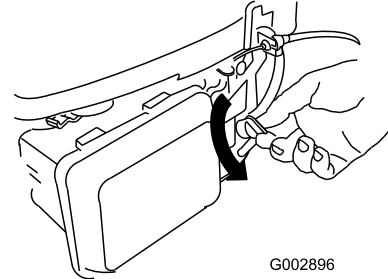

Figure 10

2. Hold the blade-control bar against the upper handle (Figure 11).

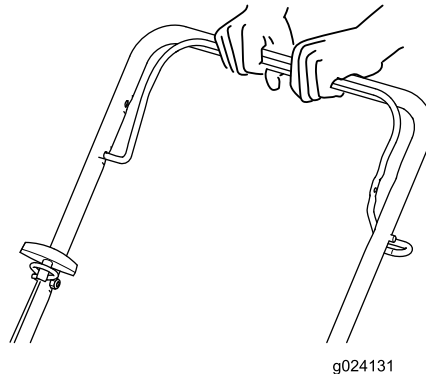

Figure 11

3. Pull the recoil-start handle (Figure 12).

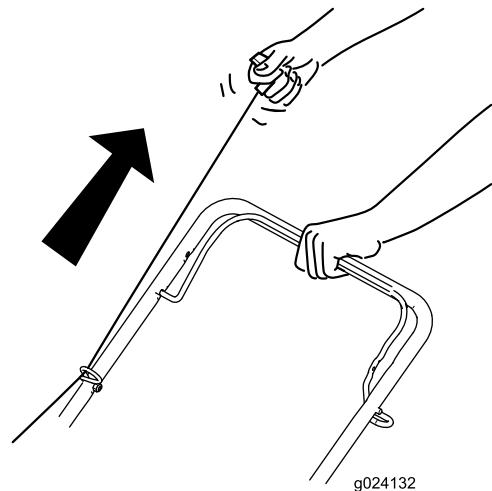

Figure 12

Adjusting the Cutting Height

⚠ WARNING

Adjusting the cutting height may bring you into contact with the moving blade, causing serious injury.

- Stop the engine and wait for all moving parts to stop.
- Do not put your fingers under the housing when adjusting the cutting height.

⚠ CAUTION

If the engine has been running, the muffler will be hot and can severely burn you. Keep away from the hot muffler.

Adjust the cutting height as desired. Set the front wheels and the rear wheels to the same height.

Note: To raise or lower the machine, move the cutting-height levers as shown in Figure 9.

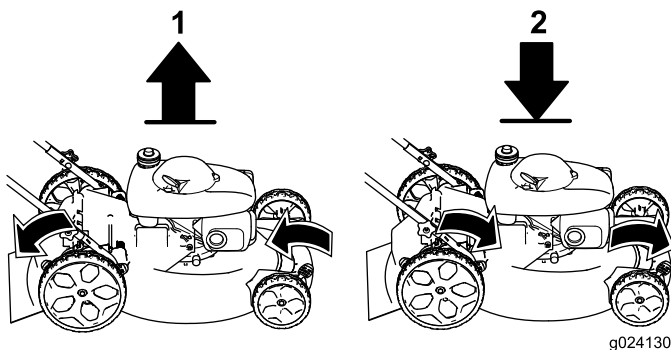

Figure 9

1. Raise the machine
2. Lower the machine

Note: If the machine does not start after several attempts, contact an Authorized Service Dealer.

Stopping the Engine

Service Interval: Before each use or daily

To stop the engine, release the blade-control bar (Figure 13).

Important: When you release the blade-control bar, both the engine and blade should stop within 3 seconds. If they do not stop properly, stop using your machine immediately and contact an Authorized Service Dealer.

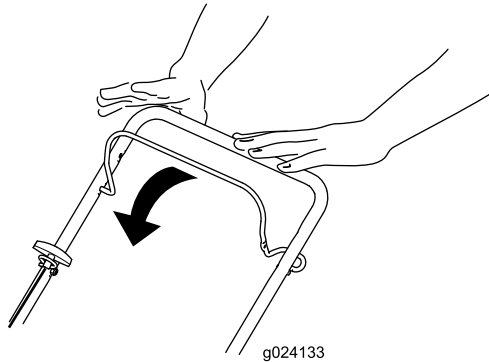

Figure 13

Mulching the Clippings

Your machine comes from the factory ready to mulch the grass and leaf clippings back into the lawn.

If the grass bag is on the machine, remove it before mulching the clippings. Refer to Removing the Grass Bag (page 9).

Bagging the Clippings

Use the grass bag when you want to collect grass and leaf clippings from the lawn.

▲ WARNING

A worn grass bag could allow small stones and other similar debris to be thrown at you or in the direction of bystanders, resulting in serious personal injury or death to you or to bystanders.

Check the grass bag frequently. If it is damaged, install a new Lawn-Boy replacement bag.

▲ WARNING

The blade is sharp; contacting the blade can result in serious personal injury.

Stop the engine and wait for all moving parts to stop before leaving the operating position.

Installing the Grass Bag

1. Lift up the rear deflector (Figure 14).

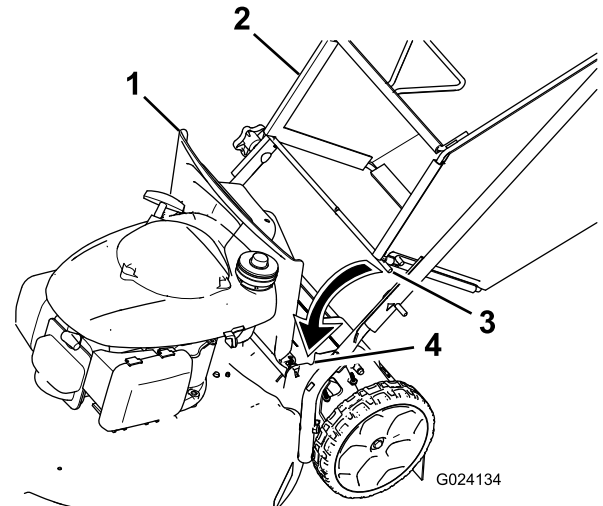

Figure 14

1. Rear deflector
2. Grass bag
3. Rod end on the grass bag (2)
4. Notch in the handle bracket (2)

2. Insert the rod ends of the grass bag into the notches in the handle brackets (Figure 14).
3. Allow the rear deflector to rest on the bag.

Removing the Grass Bag

1. Lift up the rear deflector (Figure 14).
2. Lift the grass-bag handle out from the notches on the handle brackets and remove the bag from the machine.
3. Close the rear deflector.

Operating Tips

General Mowing Tips

- Clear the area of sticks, stones, wire, branches, and other debris that the blade could hit.
- Avoid striking solid objects with the blade. Never deliberately mow over any object.
- If the machine strikes an object or starts to vibrate, immediately stop the engine, disconnect the wire from the spark plug, and examine the machine for damage.
- For best performance, install a new blade before the cutting season begins.
- Replace the blade when necessary with a Lawn-Boy replacement blade.

Cutting Grass

- Cut only about a third of the grass blade at a time. Do not cut below the 44 mm (1-3/4 inch) setting unless the grass

is sparse or it is late fall when grass growth begins to slow down. Refer to Adjusting the Cutting Height (page 8).

- When cutting grass over 15 cm (6 inches) tall, mow at the highest cutting height setting and walk slower; then mow again at a lower setting for the best lawn appearance. If the grass is too long, the machine may plug and cause the engine to stall.
- Mow only dry grass or leaves. Wet grass and leaves tend to clump on the yard and can cause the machine to plug or the engine to stall.

⚠ WARNING

Wet grass or leaves can cause serious injury if you slip and contact the blade. Mow only in dry conditions.

- Alternate the mowing direction. This helps disperse the clippings over the lawn for even fertilization.
- If the finished lawn appearance is unsatisfactory, try one or more of the following:
 - Replace the blade or have it sharpened.
 - Walk at a slower pace while mowing.
 - Raise the cutting height on your machine.
 - Cut the grass more frequently.
 - Overlap cutting swaths instead of cutting a full swath with each pass.
 - Set the cutting height on the front wheels one notch lower than the rear wheels. For example, set the front wheels at 57 mm (2-1/4 inches) and the rear wheels at 70 mm (2-3/4 inches).

Maintenance

Note: Determine the left and right sides of the machine from the normal operating position.

Recommended Maintenance Schedule(s)

Maintenance Service Interval	Maintenance Procedure
After the first 5 hours	<ul style="list-style-type: none">• Change the engine oil.
Before each use or daily	<ul style="list-style-type: none">• Check the engine-oil level.• Ensure that the engine stops within 3 seconds after releasing the blade-control bar.• Check the air cleaner for dirt and damage and clean or replace it if necessary.
After each use	<ul style="list-style-type: none">• Clean grass clippings and dirt from under the machine.
Every 25 hours	<ul style="list-style-type: none">• Clean or replace the air-cleaner element (more frequently when operating the machine in dusty or dirty operating conditions).
Every 100 hours	<ul style="list-style-type: none">• Clean the cooling system (refer to your engine owner's manual).• Replace the spark plug.
Before storage	<ul style="list-style-type: none">• Empty the fuel tank before repairs as directed and before annual storage.
Yearly	<ul style="list-style-type: none">• Change the engine oil.• Replace the blade or have it sharpened (more frequently if the edge dulls quickly).• Refer to your Engine Operator's Manual for any additional yearly maintenance procedures.

Important: Refer to your *Engine Operator's Manual* for additional maintenance procedures.

Preparing for Maintenance

1. Stop the engine and wait for all moving parts to stop.
2. Disconnect the spark-plug wire from the spark plug (Figure 15) before performing any maintenance procedure.

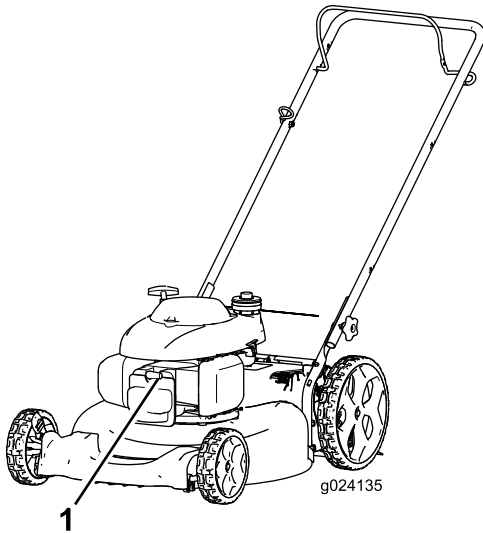

Figure 15

1. Spark-plug wire

3. After performing the maintenance procedure(s), connect the spark-plug wire to the spark plug.

Important: Before tipping the machine to change the oil or replace the blade, allow the fuel tank to run dry through normal usage. If you must tip the machine prior to running out of fuel, use a hand fuel pump to remove the fuel. Always tip the machine onto its side with the dipstick down.

⚠ WARNING

Tipping the machine may cause the fuel to leak. Gasoline is flammable, explosive and can cause personal injury.

Run the engine dry or remove the gasoline with a hand pump; never siphon.

Servicing the Air Cleaner

Service Interval: Before each use or daily

Every 25 hours/Yearly (whichever comes first)—Clean or replace the air-cleaner element (more frequently when operating the machine in dusty or dirty operating conditions).

1. Press down on the latch tabs on top of the air-cleaner cover (Figure 16).

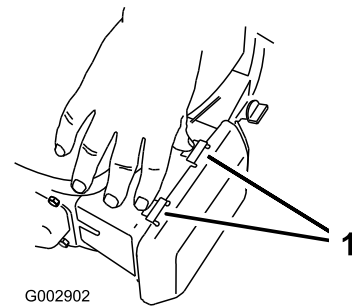

Figure 16

1. Latch tabs

2. Open the cover.
3. Remove the air-cleaner element (Figure 16).

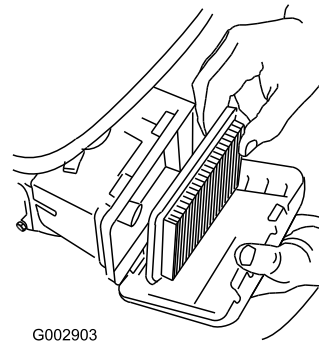

Figure 17

4. If the air-cleaner element is damaged or is wet with oil or fuel, replace it.
5. If the air-cleaner element is dirty, tap it on a hard surface several times or blow compressed air less than 207 kPa (30 psi) through the side of the filter that faces the engine.

Note: Do not brush the dirt off the filter; brushing forces dirt into the fibers.

6. Remove dirt from the air-cleaner body and cover using a moist rag. **Do not wipe dirt into the air duct.**
7. Install the air-cleaner element into the air cleaner.
8. Close the cover.

Changing the Engine Oil

Service Interval: After the first 5 hours

Yearly

Run the engine a few minutes before changing the oil to warm it. Warm oil flows better and carries more contaminants.

1. Perform the pre-maintenance procedures; refer to Preparing for Maintenance (page 12).
2. Remove the dipstick.
3. Tip the machine onto its side, with the dipstick down, to drain the used oil out through the oil-fill tube (Figure 18).

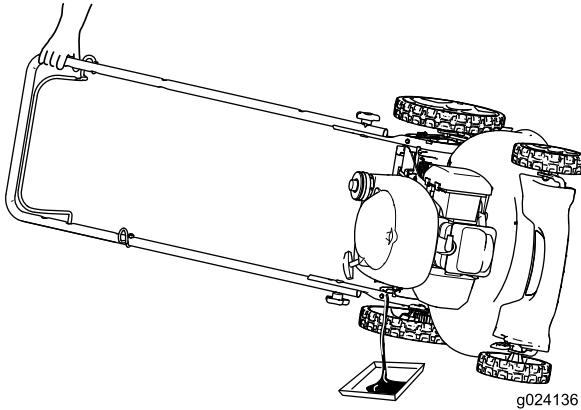

Figure 18

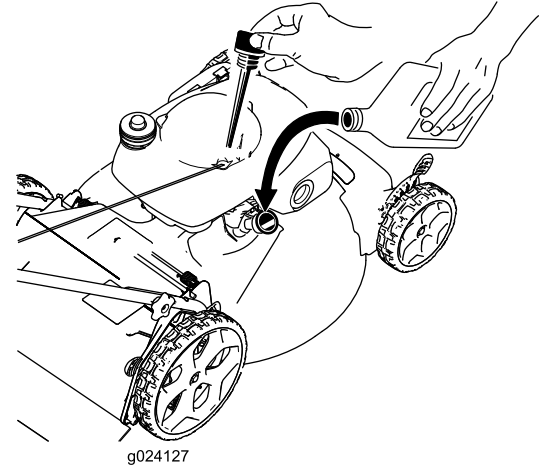
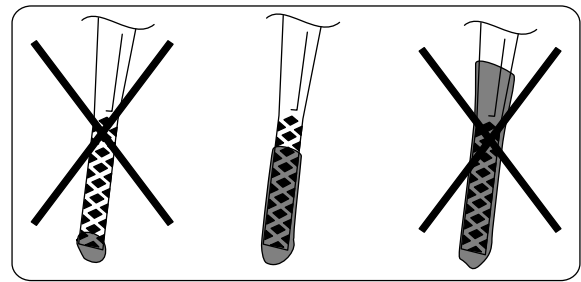

Figure 19

4. After draining the used oil, return the machine to the normal operating position.
5. Pour about 3/4 of the crankcase capacity of oil into the oil-fill tube.

Note: Max. fill: 0.55 L (18.6 oz), type: SAE 30 or SAE 10W-30 detergent oil with an API service classification of SF, SG, SH, SJ, SL, or higher.

6. Wipe off the dipstick end with a clean cloth.
7. Insert the dipstick into the oil-fill tube, but **do not** screw it in.
8. Remove the dipstick and read the oil level on the dipstick (Figure 19).

- If the oil level is low, add a small amount of oil slowly to the oil-fill tube, and then repeat steps 6 through 8 until the oil level on the dipstick is correct.
 - If the oil level is high, drain the excess oil until the oil level on the dipstick is correct.
- Important:** If the oil level in the crankcase is too low or too high and you run the engine, you may damage the engine.

9. Install the dipstick securely.
10. Recycle the used oil properly.

Replacing the Blade

Service Interval: Yearly

Important: You will need a torque wrench to install the blade properly. If you do not have a torque wrench or are uncomfortable performing this procedure, contact an Authorized Service Dealer.

Examine the blade whenever you run out of gasoline. If the blade is damaged or cracked, replace it immediately. If the blade edge is dull or nicked, have it sharpened or replace it.

▲ WARNING

The blade is sharp; contacting the blade can result in serious personal injury.

- Disconnect the wire from the spark plug.
- Wear gloves when servicing the blade.

1. Disconnect the spark-plug wire from the spark plug. Refer to Preparing for Maintenance (page 12).
2. Tip the machine onto its side, with the air filter up.
3. Use a block of wood to hold the blade steady.
4. Remove the blade (turn the blade bolt counterclockwise), saving all the mounting hardware.
5. Install the new blade (turn the blade bolt clockwise) and all mounting hardware (Figure 20).

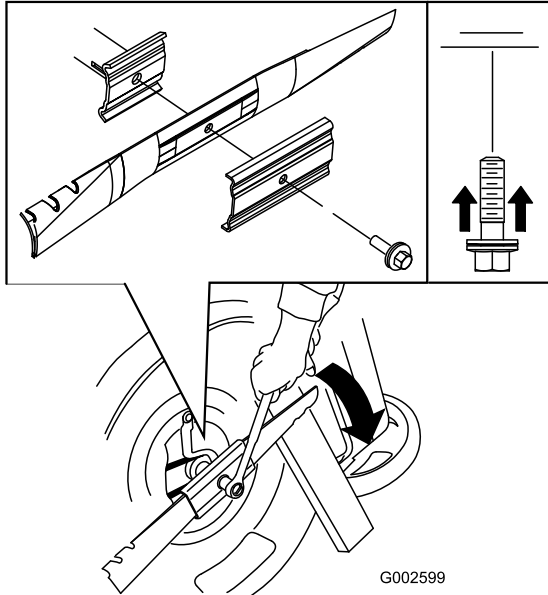

Figure 20

Important: Position the curved ends of the blade to point toward the machine housing.

6. Use a torque wrench to tighten the blade bolt to 82 N-m (60 ft-lb).

Important: A bolt torqued to 82 N-m (60 ft-lb) is very tight. While holding the blade with a block of wood, put your weight behind the ratchet or wrench and tighten the bolt securely. This bolt is very difficult to overtighten.

Cleaning the Underside of the Machine

Service Interval: After each use

⚠ WARNING

The machine may dislodge material from under the machine housing.

- Wear eye protection.
 - Stay in the operating position (behind the handle).
 - Do not allow bystanders in the area.
1. With the engine running on a flat paved surface, spray a stream of water in front of the **right** rear wheel (Figure 21).

The water will splash into the path of the blade, cleaning out the clippings.

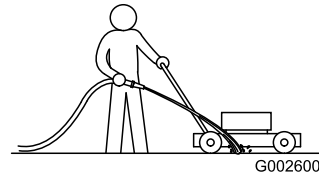

Figure 21

2. When no more clippings come out, stop the water and move the machine to a dry area.
3. Run the engine for a few minutes to dry the housing to prevent it from rusting.

Storage

Store the machine in a cool, clean, dry place.

Preparing the Machine for Storage

⚠ WARNING

Gasoline vapors can explode.

- Do not store gasoline more than 30 days.
 - Do not store the machine in an enclosure near an open flame.
 - Allow the engine to cool before storing it.
1. On the last refueling of the year, add fuel stabilizer to the fuel as directed by the engine manufacturer.
 2. Run the machine until the engine stops from running out of fuel.
 3. Prime the engine and start it again.
 4. Allow the engine to run until it stops. When you can no longer start the engine, it is sufficiently dry.
 5. Disconnect the wire from the spark plug.
 6. Remove the spark plug, add 30 ml (1 oz) of oil through the spark plug hole, and pull the starter rope **slowly** several times to distribute oil throughout the cylinder to prevent cylinder corrosion during the off-season.
 7. Install the spark plug and tighten it with a torque wrench to 20 N-m (15 ft-lb).
 8. Tighten all nuts, bolts, and screws.

Folding the Handle

⚠ WARNING

Folding or unfolding the handle improperly can damage the cables, causing an unsafe operating condition.

- Do not damage the cables when folding or unfolding the handle.
 - If a cable is damaged, contact an Authorized Service Dealer.
1. Loosen the handle knobs until you can move the handle freely (Figure 22).

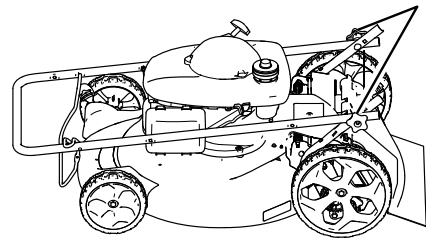
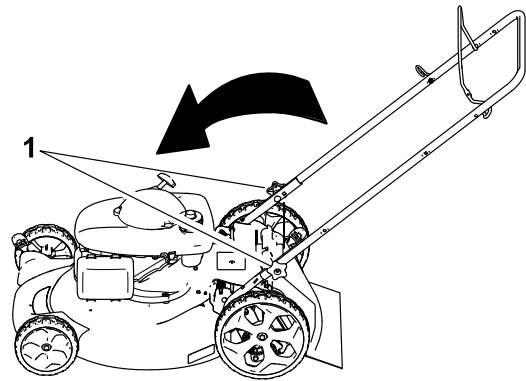

Figure 22

1. Handle knob (2)

2. Move the handle forward as shown in Figure 22.

Removing the Machine from Storage

1. Remove the spark plug and spin the engine rapidly by pulling the recoil-start handle to blow the excess oil from the cylinder.
2. Install the spark plug and tighten it with a torque wrench to 20 N-m (15 ft-lb).
3. Connect the wire to the spark plug.



The Lawn-Boy No-Worry Warranty

A 2-Year Full Warranty (45 Day Limited Warranty for Commercial Use)

21 in. Mulching/Rear Bagging

Walk Power Mowers

The Lawn-Boy True Start Commitment

A 3-Year Full Warranty (Not Applicable for Commercial Use)

Conditions and Products Covered

Lawn-Boy Inc. and its affiliate, Lawn-Boy Warranty Company, pursuant to an agreement between them, jointly promise to repair the Lawn-Boy Product listed below if used for residential purposes*; if it is defective in materials or workmanship or if it stops functioning due to the failure of a component; or if the Lawn-Boy True Start engine will not start on the first or second pull, provided the routine maintenance required in the *Operator's Manual* have been performed.

This warranty covers the cost of parts and labor, but you must pay transportation costs.

The following time periods apply from the date of purchase:

Products	Warranty Period
21 in. Mulching/Rear Bagging Mowers and Attachments	2 - year full warranty
True Start Commitment	3 - year full warranty
Engine	3 - year full warranty
Battery	1 - year full warranty
Wear Items (Belts, blades, blade adaptors, grass bags, cables, and wheels)	90 days

Limited Warranty for Commercial Use*

Gas-powered Lawn-Boy Products used for commercial, institutional, or rental use, are warranted for 45 days against defects in materials or workmanship. Components failing due to normal wear are not covered by this warranty.

The True Start Commitment does not apply when the product is used commercially*.

Instructions for Obtaining Warranty Service

If you think that your Lawn-Boy Product contains a defect in materials or workmanship, or if a normal, able-bodied adult can no longer start your product's engine in one or two pulls, follow this procedure:

- Contact any Authorized Lawn-Boy Service Dealer to arrange service at their dealership. To locate a dealer convenient to you, refer to the *Yellow Pages* of your telephone directory (look under "Lawn Mowers") or access our web site at www.Lawn-Boy.com. You may also call the numbers listed in item #3 to use the 24-hour Lawn-Boy Dealer locator system.
- Bring the product and your proof of purchase (sales receipt) to the Service Dealer. The dealer will diagnose the problem and determine if it is covered under warranty.
- If for any reason you are dissatisfied with the Service Dealer's analysis or with the assistance provided, contact us at:

Customer Care Department
Lawn-Boy Inc.
8111 Lyndale Avenue South
Bloomington, MN 55420-1196
Toll free at 866-216-6032 (U.S. customers)
Toll free at 866-216-6031 (Canadian customers)

Owner Responsibilities

You must maintain your Lawn-Boy Product by following the maintenance procedures described in the *Operator's Manual*. Such routine maintenance, whether performed by a dealer or by you, is at your expense.

Countries Other than the United States or Canada

Customers who have purchased Lawn-Boy products exported from the United States or Canada should contact their Lawn-Boy Distributor (Dealer) to obtain guarantee policies for your country, province, or state. If for any reason you are dissatisfied with your Distributor's service or have difficulty obtaining guarantee information, contact the Lawn-Boy importer. If all other remedies fail, you may contact us at Lawn-Boy Warranty Company.

Australian Consumer Law: Australian customers will find details relating to the Australian Consumer Law either inside the box or at your local Lawn-Boy Dealer.

*Residential purposes means use of the product on the same lot as your home. Use at more than one location, or institutional or rental use, is considered commercial use and the commercial use warranty would apply.

Items and Conditions Not Covered

There is no other express warranty except for special emission system coverage and engine warranty coverage on some products. This express warranty does not cover the following:

- Cost of regular maintenance service or parts, such as filters, fuel, lubricants, oil changes, spark plugs, air filters blade sharpening or worn blades, cable/linkage adjustments, or brake and clutch adjustments
- Components failing due to normal wear
- Any product or part which has been altered or misused or neglected and requires replacement or repair due to accidents or lack of proper maintenance
- Pickup and delivery charges
- Repairs or attempted repairs by anyone other than an Authorized Lawn-Boy Service Dealer
- Repairs necessary due to failure to follow recommended fuel procedure (consult *Operator's Manual* for more details)
 - Removing contaminants from the fuel system is not covered
 - Use of old fuel (more than one month old) or fuel which contains more than 10% ethanol or more than 15% MTBE
 - Failure to drain the fuel system prior to any period of non-use over one month
- Repairs or adjustments to correct starting difficulties due to the following:
 - Failure to follow proper maintenance procedures or recommended fuel procedure
 - Rotary mower blade striking an object
- Special operational conditions where starting may require more than two pulls:
 - First time starts after extended period of non-use over three months or seasonal storage
 - Cool temperature starts such as those found in early spring and late autumn
 - Improper starting procedures - if you are having difficulty starting your unit, please check the *Operator's Manual* to ensure that you are using the correct starting procedures. This can save an unnecessary visit to an Authorized Lawn-Boy Service Dealer.

General Conditions

All repairs covered by these warranties must be performed by an Authorized Lawn-Boy Service Dealer using Lawn-Boy-approved replacement parts. Repair by an Authorized Lawn-Boy Service Dealer is your sole remedy under this warranty.

Lawn-Boy Inc. nor Lawn-Boy Warranty Company is liable for indirect, incidental, or consequential damages in connection with the use of the Lawn-Boy Products covered by these warranties, including any cost or expense of providing substitute equipment or service during reasonable periods of malfunction or non-use pending completion of repairs under these warranties.

Some states do not allow exclusions of incidental or consequential damages, so the above exclusions may not apply to you.

This warranty gives you specific legal rights, and you may also have other rights which vary from state to state.