



Insight[®] Gold Lawn Mower

Model No. 10695 - 270000001 and up.

Parts Catalog

Ordering Replacement Parts

To order replacement parts, please supply the part number, the quantity, and the description of each part desired.

Understanding Reference Numbers

Each identified part in an illustration has a reference number. The reference number for a part also appears in the parts list, along with other information about the part.

This catalog uses two special reference number formats, one to indicate parts in a service assembly and another to indicate the quantity of a given part in an illustration.

Service Assembly Reference Numbers

Parts in service assemblies have reference numbers in the form a:b. The a represents the reference number of the entire service assembly and the b represents a sequential number unique to each part within the service assembly.

For example, a wheel assembly might be identified by reference number 6, the tire by 6:1, the valve by 6:2, and the wheel by 6:3. When you order the assembly identified by reference number 6, you receive all parts identified by reference numbers 6:1, 6:2, and 6:3. However, you may also order any part individually. Reference numbers of this type appear in illustrations and in part lists.

Reference Numbers Indicating Quantity

In an illustration, if a reference number indicates more than one part, the reference number has the form nX y. The n represents the quantity of the part, the X is the multiplication symbol, and the y represents the reference number.

For example, in an illustration, the reference number 2X 37 means that two of the parts identified by reference number 37 are indicated.

Contents

Description	Page	Description	Page
Front End and Tunnel Assembly 3	Camshaft Pulley Assembly Honda GCV160A STL1 15
Housing Assembly No. 108-9346 4	Recoil Starter Assembly Honda GCV160A STL1 16
Rear Axle and Transmission Assembly 5	Fan Cover Assembly Honda GCV160A STL1 17
Transmission Assembly No. 107-3860 6	Carburetor Assembly Honda GCV160A STL1 18
Upper Handle Assembly 7	Air Cleaner Assembly Honda GCV160A STL1 19
Lower Handle Assembly 8	Muffler Assembly Honda GCV160A STL1 20
Blade and Engine Assembly 9	Flywheel Assembly Honda GCV160A STL1 21
Rear Bag Assembly 10	Control Assembly Honda GCV160A STL1 22
Cylinder Barrel Assembly Honda GCV160A STL1 11	Choke Base Assembly Honda GCV160A STL1 23
Oil Pan Assembly Honda GCV160A STL1 12	Top Cover Assembly Honda GCV160A STL1 24
Crankshaft Assembly Honda GCV160A STL1 13	Label Assembly Honda GCV160A STL1 25
Piston and Connecting Rod Assembly Honda GCV160A STL1 14	Attachments and Accessories List 26

Part Description Abbreviations

Part descriptions in this catalog may include the following abbreviations.

AR. as required	HYD. hydraulic
ASM. assembly	LH. left hand
BBC. blade brake clutch	NI. nylon insert
CARR. carriage	NPTF. national pipe thread fine
DEG. degrees	PFH. phillips flat head
EXT. external	PPH. phillips pan head
FH. flat head	PPHTF. phillips pan head thread forming
GA. gauge	PRH. phillips round head
HD. heavy-duty	PTH. phillips truss head
HF. hex flange	PTO. power-take-off
HH. hex head	RH. right hand
HHF. hex head flange	ROPS. roll-over protection system
HHFTF. hex head flange thread forming	SFH. slotted fillister head
HJ. hex jam	SHH. slotted hex head
HLH. hex lag head	SHWH. slotted hex washer head
HOC. height-of-cut	SPH. slotted pan head
HSBH. hex socket button head	SQH. square head
HSFH. hex socket flat head	SRH. slotted round head
HSH. hex socket head	STD. standard
HWH. hex washer head	TAP. self tapping
HWHTF. hex washer head thread forming	TTH. torx truss head

Footnotes

- ❶ Not illustrated
- ❷ Obtain from your local Honda dealer

- ❸ Not serviced separately

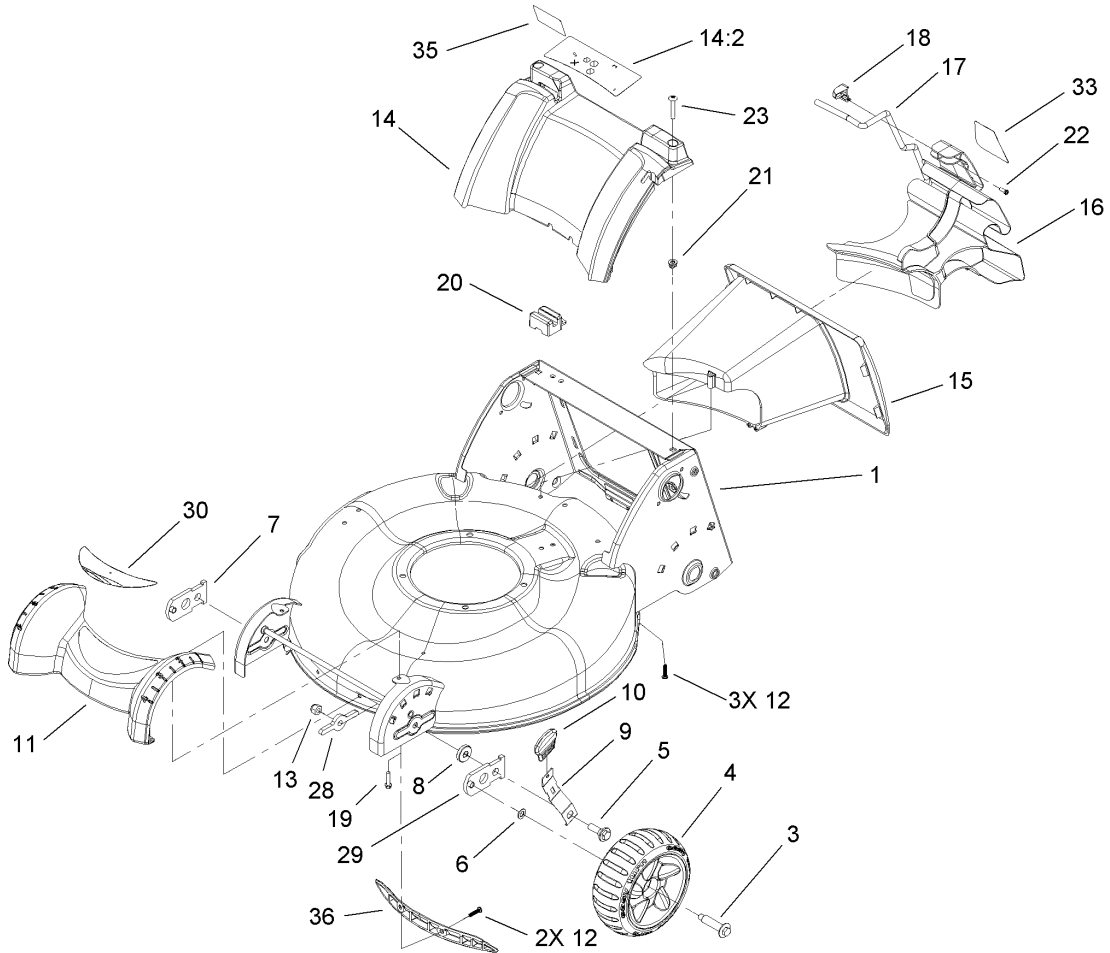

Front End and Tunnel Assembly

Ref	Part No.	Qty.	Description	Ref	Part No.	Qty.	Description
1	108-9346	1	Housing ASM	29	108-1044	1	Arm-Pivot, LH
3	614650	2	Bolt-Shoulder	30	108-7453	1	Decal
4	112-1548	2	7 Inch Front Wheel ASM	33	108-7461	1	Decal
5	614672	2	Bolt-Shoulder	35	107-1938	1	Decal-Bag Attachment
6	40-1940	2	Washer	36	108-7502	1	Insert-Housing
7	107-3877	1	Arm-Pivot, RH	●39	110-1751	1	Mulch Plug ASM
8	92-4890	2	Washer				
9	107-3878	2	Arm-Spring				
10	107-1904	2	Knob-Lever, HOC				
11	107-3926	1	Cover-Front				
12	108-7476	5	Screw-Plastite				
13	3296-39	2	Nut-Lock, NI				
14	108-9349	1	Cover-Rear				
14:2	107-3888	1	Decal-Safety				
15	110-9455	1	Tunnel				
16	107-3907	1	Plug-Chute				
17	108-1038	1	Latch-Plug				
18	108-0956	1	Retainer-Latch				
19	108-7475	2	Screw-Plastite				
20	110-1786	1	Module-Switch				
21	94-1610	2	Nut-Clip				
22	32144-111	1	Screw-PPH				
23	108-0965	2	Screw-PTH				
28	108-1048	2	Washer-Support, Front				

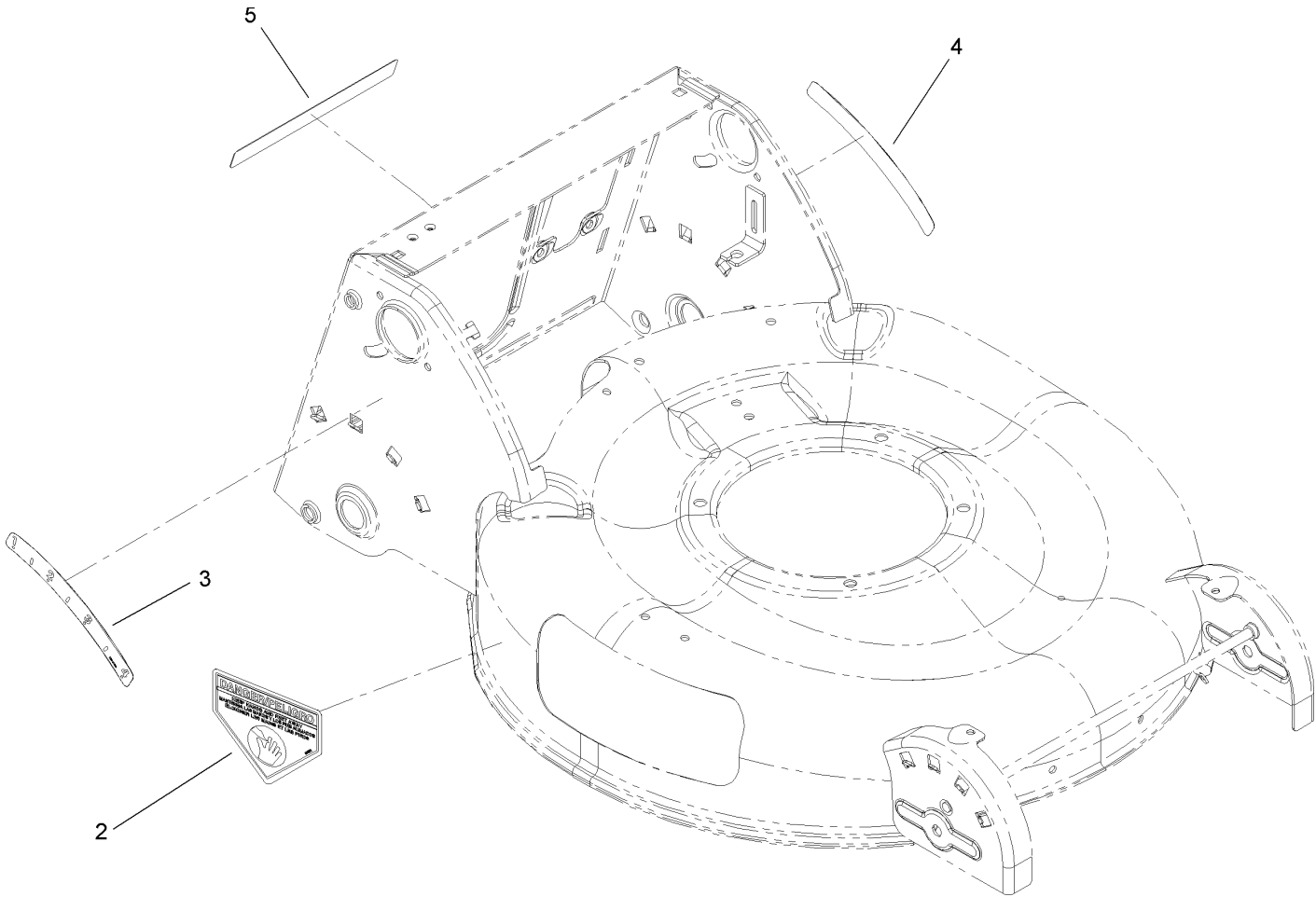

Housing Assembly No. 108-9346

Ref	Part No.	Qty.	Description				
2	94-8072	1	Decal-Danger				
3	108-7450	1	Decal-HOC, RH				
4	108-7451	1	Decal-HOC, LH				
5	107-3889	1	Decal-Safety				

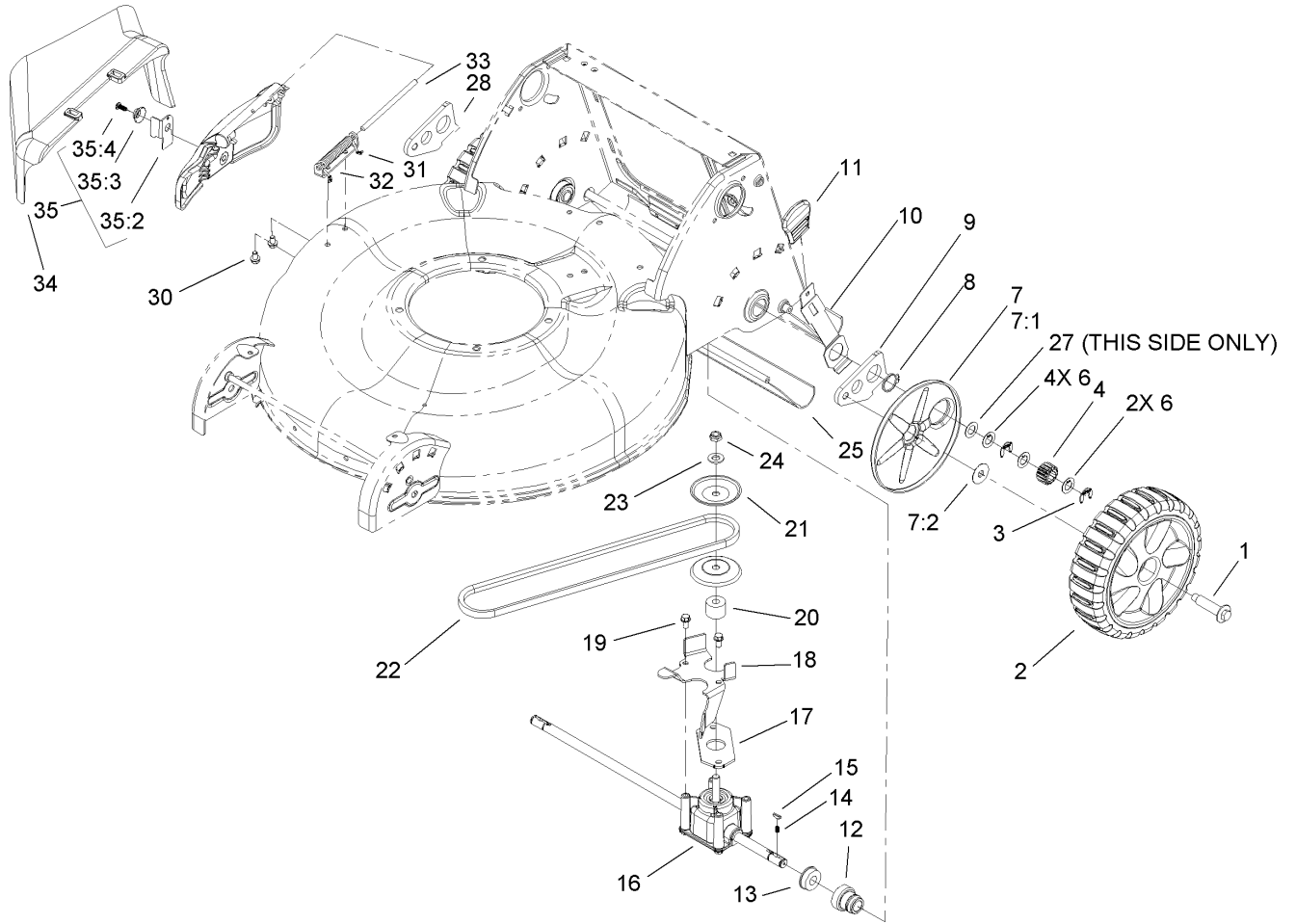

Rear Axle and Transmission Assembly

Ref	Part No.	Qty.	Description
1	614650	2	Bolt-Shoulder
2	107-3906	2	Rear Wheel ASM
3	65-2720	4	Klipring-Locking
4	105-3040	2	Gear-Pinion, 15T
6	105-6840	6	Washer-Thrust
7	110-1793	2	Wheel Cover ASM
7:1		1	Cover-Wheel
7:2	614426	1	Washer-Stepped
8	32151-36	2	Ring-Retaining
9	108-9344	1	Arm-Rear Pivot, LH
10	110-9445	2	Arm-Spring, Rear
11	107-1904	2	Knob-Lever, HOC
12	104-8698	2	Retainer-Bearing, HOC
13	104-8699	2	Bearing-Ball
14	39-9650	2	Spring-Compression
15	612066	2	Key
16	107-3860	1	Transmission ASM
17	108-9756	1	Gasket-Gearbox
18	107-3884-03	1	Bracket-Transmission
19	32144-4	2	Screw-HWH
20	92-5791	1	Spacer
21	100-1176	2	Pulley-Half
22	91-2258	1	V-Belt
23	3256-24	1	Washer-Flat

Ref	Part No.	Qty.	Description
24	3296-5	1	Nut-Lock
25	112-8768	1	Shield-Trailing
27	36-4780	1	Washer-Plain
28	108-9343	1	Arm-Rear Pivot, RH
30	99-8445	2	Screw-HWH
31	99-5293	1	Spring-Torsion
32	112-6416	1	Bracket-Cover
33	99-5291	1	Rod-Cover
34	105-3028	1	Chute-Discharge, Side
35	106-8376	1	Discharge Door ASM
35:2	107-0795	1	Latch-Door
35:3	107-7456	1	Cap-Door
35:4	107-7461	1	Screw-Plastite

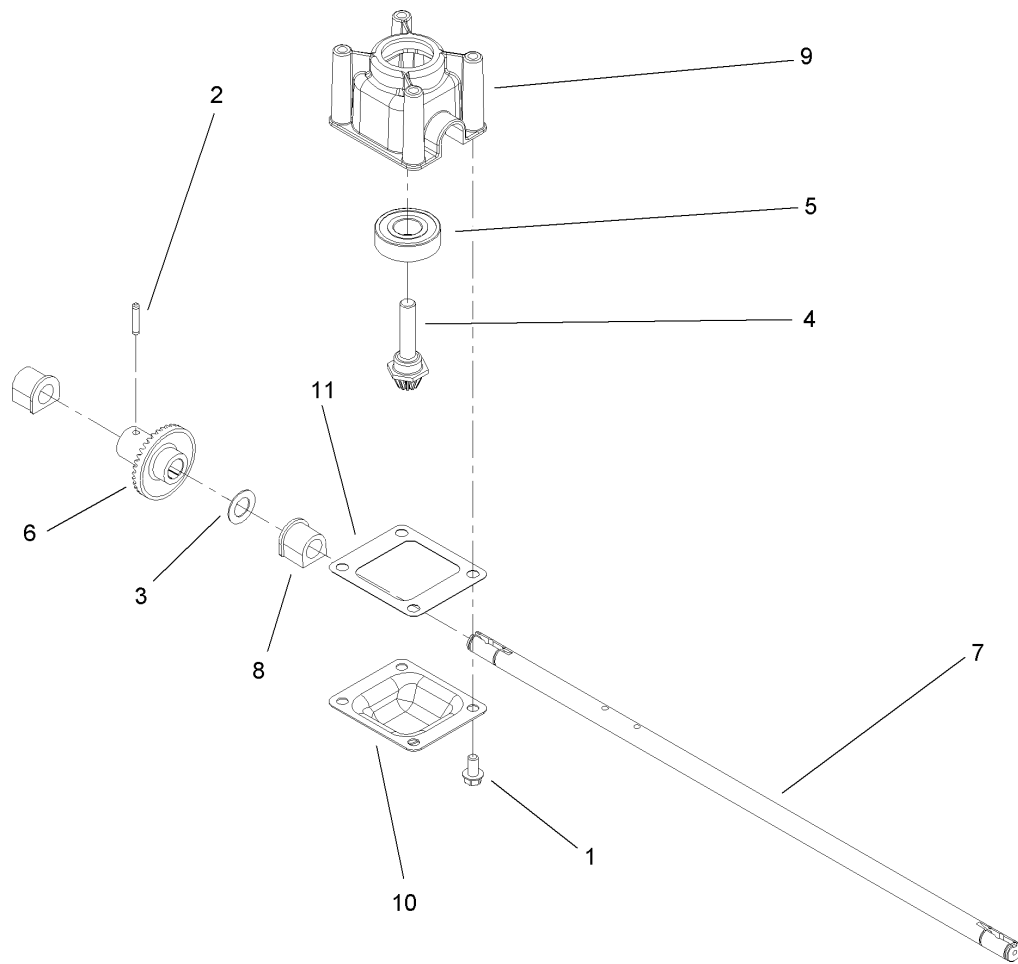

Transmission Assembly No. 107-3860

Ref	Part No.	Qty.	Description
1	32144-4	4	Screw-HWH
2	3285-19	1	Pin-Groove
3	36-4780	1	Washer-Plain
4	92-5790	1	Pinion
5	100-1048	1	Bearing-Ball
6	104-8671	1	Gear-Bevel, 37T
7	107-3861	1	Shaft-Output
8	104-8673	2	Bushing-Shaft, Output
9	104-8674	1	Gearcase-Upper
10	104-8675-03	1	Cover-Gearcase
11	105-6839	1	Gasket-Gearcase

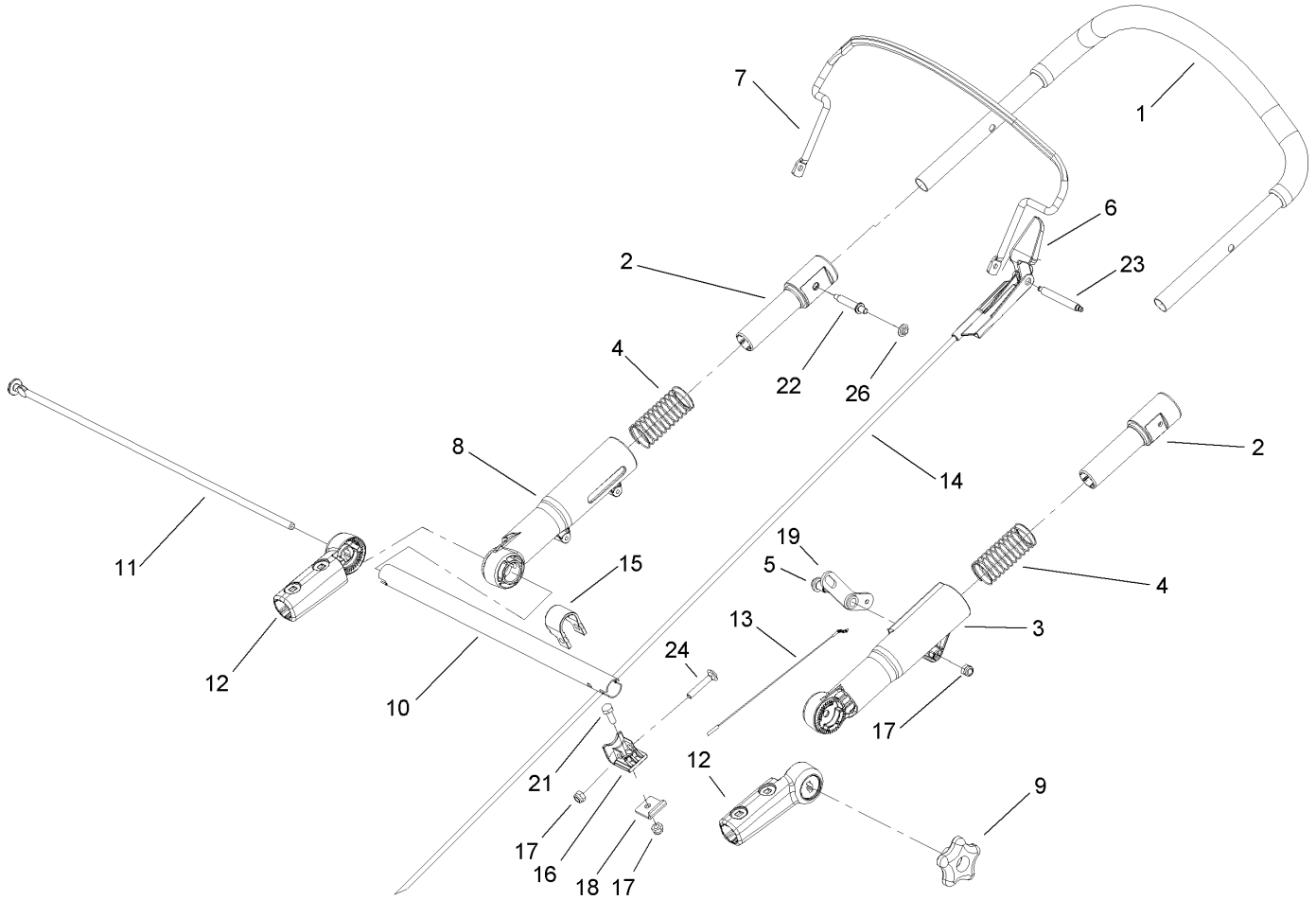

Upper Handle Assembly

Ref	Part No.	Qty.	Description
1	108-0974	1	Upper Handle ASM
2	112-8754	2	Sleeve-Inner
3	112-1544	1	Sleeve-Outer, LH
4	107-3869	2	Spring-Compression
5	104-0858	1	Bolt-Shoulder
6	112-8764	1	Stop-Pivot
7	110-1819-03	1	Bail-Brake
8	112-1545	1	Sleeve-Outer, RH
9	107-3937	1	Knob
10	107-3867-03	1	Tube-Cross
11	107-3871	1	Rod-Threaded
12	107-3865	2	Mount-Handle, Lower
13	107-3902	1	Cable-Traction
14	107-3903	1	Cable-Brake
15	108-1045	1	Support-Cable
16	108-1046	1	Support-Guide, Cable
17	3296-73	3	Nut-Lock, NI
18	108-7454	1	Clamp-Cable
19	107-3893	1	Lever-Traction
21	321-4	1	Screw-HH
22	108-0959	1	Pin-Handle
23	108-1008	1	Pin-Bail, LH
24	108-0988	1	Screw-CARR
26	108-9378	1	Retainer-Push On

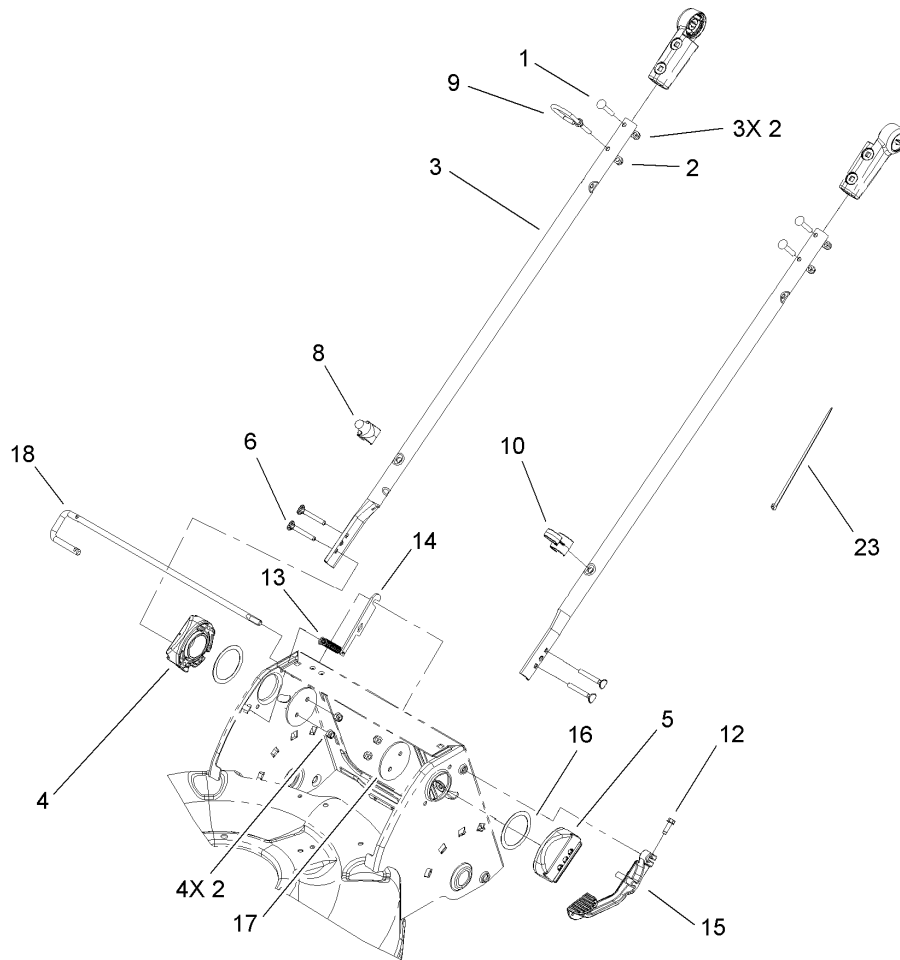

Lower Handle Assembly

Ref	Part No.	Qty.	Description
1	108-0988	3	Screw-CARR
2	3296-73	8	Nut-Lock, NI
3	107-3887-03	2	Tube-Lower
4	108-9339-03	1	Mount-Handle, RH
5	108-9340-03	1	Mount-Handle, LH
6	95-4453	4	Screw
8	108-0994	1	Guide-Rope, Lower
9	107-3908	1	Guide-Rope, Upper
10	106-6805	1	Guide-Cable
12	49-2040	1	Screw-HWHTF
13	112-1542	1	Spring-Extension
14	112-1539	1	Plate-Release Rod
15	110-1823-03	1	Lever-Release
16	107-3947	2	Washer-Nylon
17	107-3944-03	2	Plate
18	112-8755	1	Handle-Rod, Release
23	614249	1	Strap-Tie

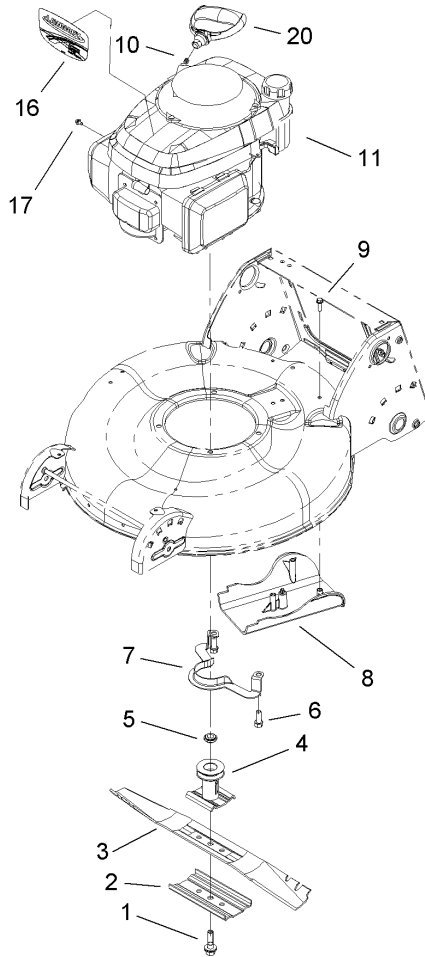

Blade and Engine Assembly

Ref	Part No.	Qty.	Description				
1	105-8579	1	Bolt-Blade				
2	108-3766-03	1	Support-Blade				
3	108-0954-03	1	Blade-21 Inch				
4	106-3987	1	Blade Driver ASM				
5	106-3999	1	Spacer-Driver				
6	92-1624	3	Screw				
7	105-3030-03	1	Guide-Belt				
8	110-1832	1	Cover-Belt				
9	46-8091	3	Screw-HWH				
10	92-1701	1	Stop-Rope				
11		1	Engine-Honda, Gcv160A Stl1				
16	108-7529	1	Decal				
17	98-1394	1	Screw-HWH				
20	110-1778	1	Handle-Recoil				

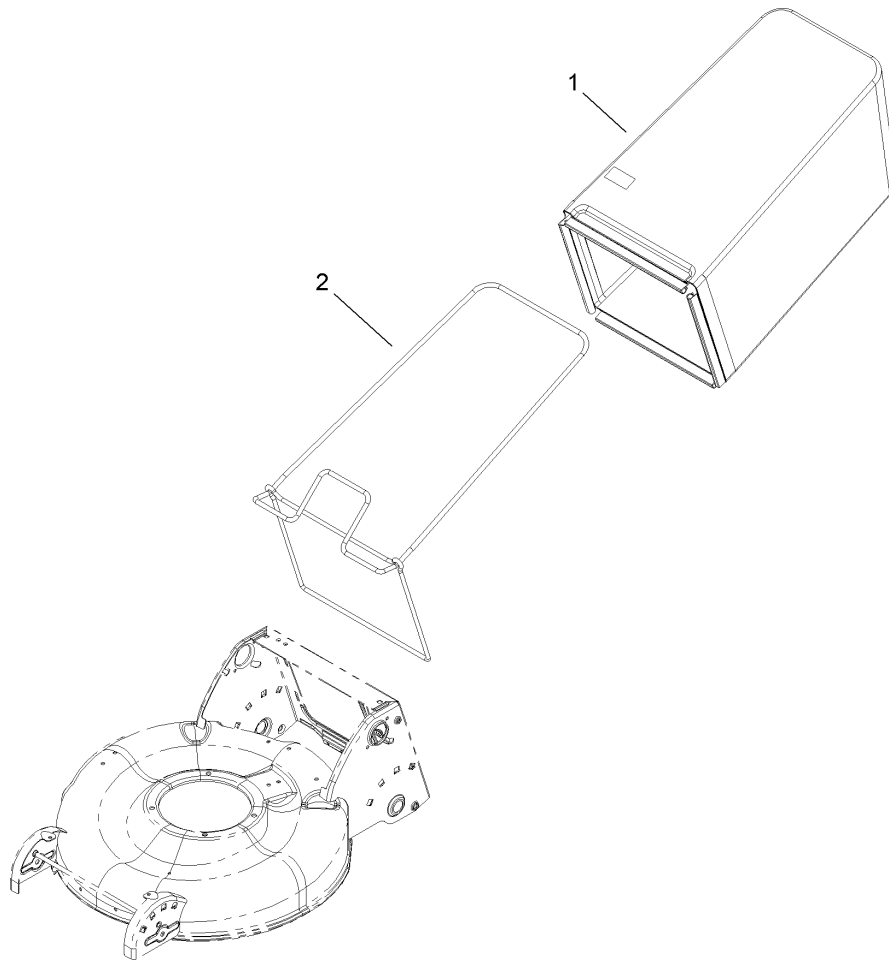

Rear Bag Assembly

Ref	Part No.	Qty.	Description
1	107-3911	1	Bag-Grass
2	112-8750-03	1	Frame-Bag

--	--	--	--

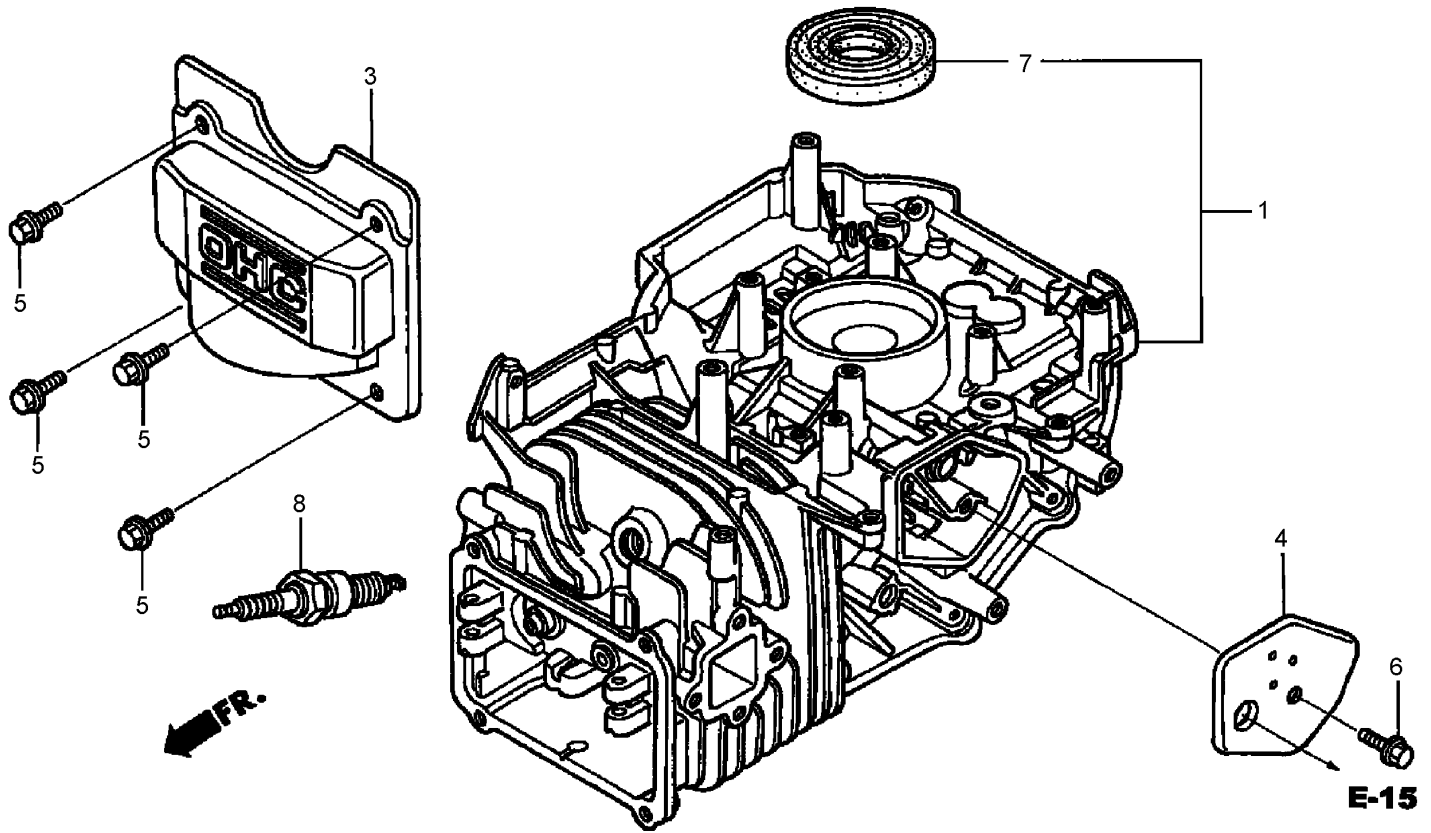

E-15

Cylinder Barrel Assembly Honda GCV160A STL1

Ref	Part No.	Qty.	Description
1	12000-ZL8-415	1	Cylinder ASM (010)
3	12311-ZL8-000	1	Cover-Head
4	12355-ZL8-000	1	Cover-Breather (Breather Valve ASM)
5	90013-883-000	4	Bolt-Flange (6X12) (Cl200)
6	90014-952-000	1	Bolt-Flange (6X14)
7	91201-ZL8-003	1	Seal (25.4X62X6)
8	98079-56846	1	Plug-Spark (Bpr6Es) (Ngk)

--	--	--	--

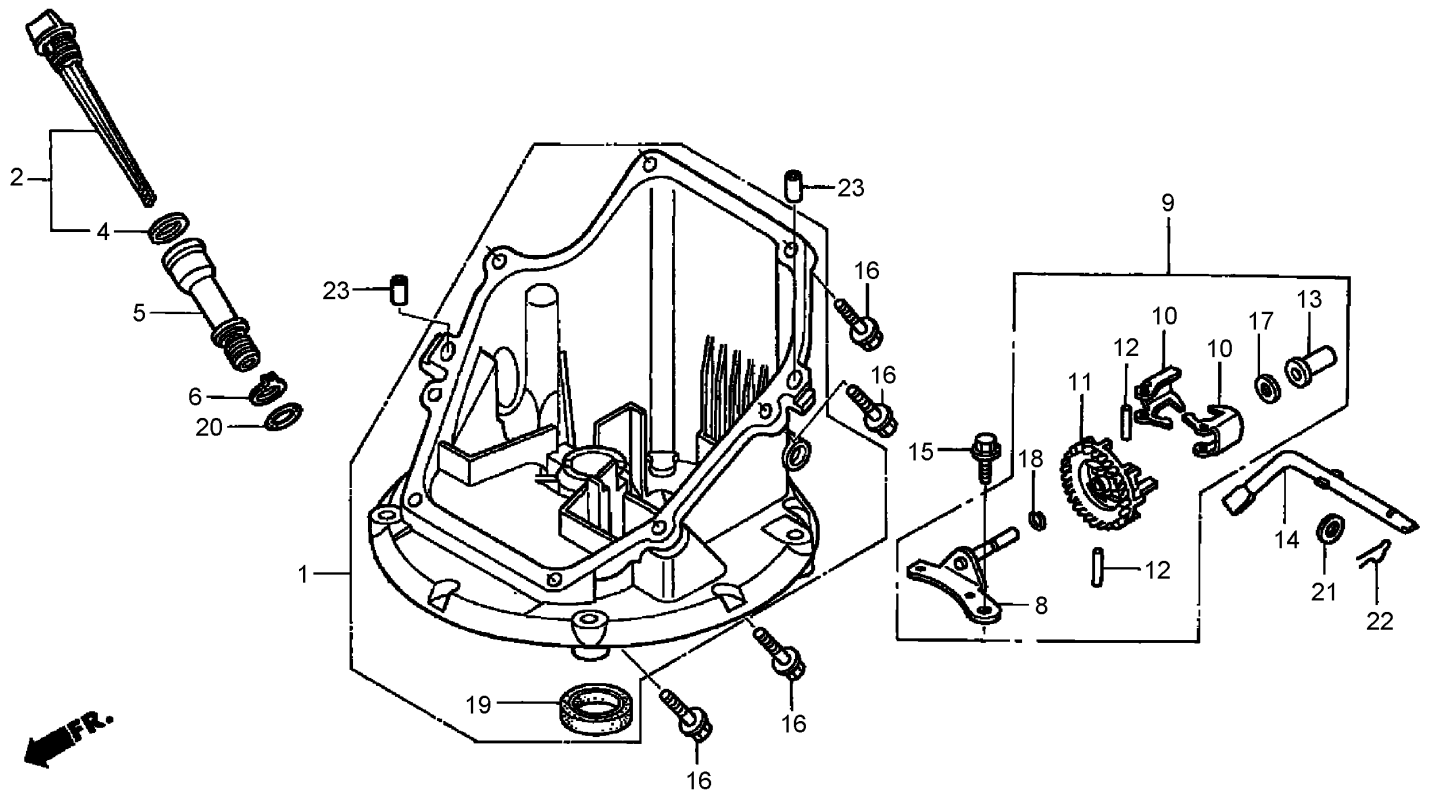

Oil Pan Assembly Honda GCV160A STL1

Ref	Part No.	Qty.	Description
❶	11300-ZM0-405	1	Oil Pan ASM (000)
❷	15650-ZM0-801	1	Dipstick-Oil
❸	15625-ZE6-000	1	Gasket-Cap, Oil Filler
❹	15631-ZM0-000	1	Extension-Filler, Oil
❺	15639-ZM0-000	1	Washer-Lock, Extension
❻	16508-ZM0-010	1	Shaft-Holder, Governor
❼	16510-ZM0-010	1	Governor ASM
❽	16511-ZL8-000	2	Weight-Governor
❾	16512-ZM0-000	1	Holder-Weight, Governor
❿	16513-ZE1-000	2	Pin-Weight, Governor
⓫	16531-ZE1-000	1	Slider-Governor
⓬	16541-ZM0-000	1	Shaft-Arm, Governor
⓭	90014-952-000	1	Bolt-Flange (6X14)

Ref	Part No.	Qty.	Description
❶	90121-952-000	8	Bolt-Flange (6X25)
❷	90451-ZE1-000	1	Washer-Thrust (6Mm)
❸	90602-ZE1-000	1	Clip-Holder, Governor
❹	91202-ZL8-003	1	Seal-Oil (28X41.25X6)
❺	91303-KF0-003	1	O-Ring (14.8X2.4) (Arai)
❻	91356-MA6-005	1	O-Ring
❼	94101-06800	1	Washer-Plain (6Mm)
❽	94251-08000	1	Pin-Lock (8Mm)
❾	94301-08200	2	Pin-Dowel (8X20)

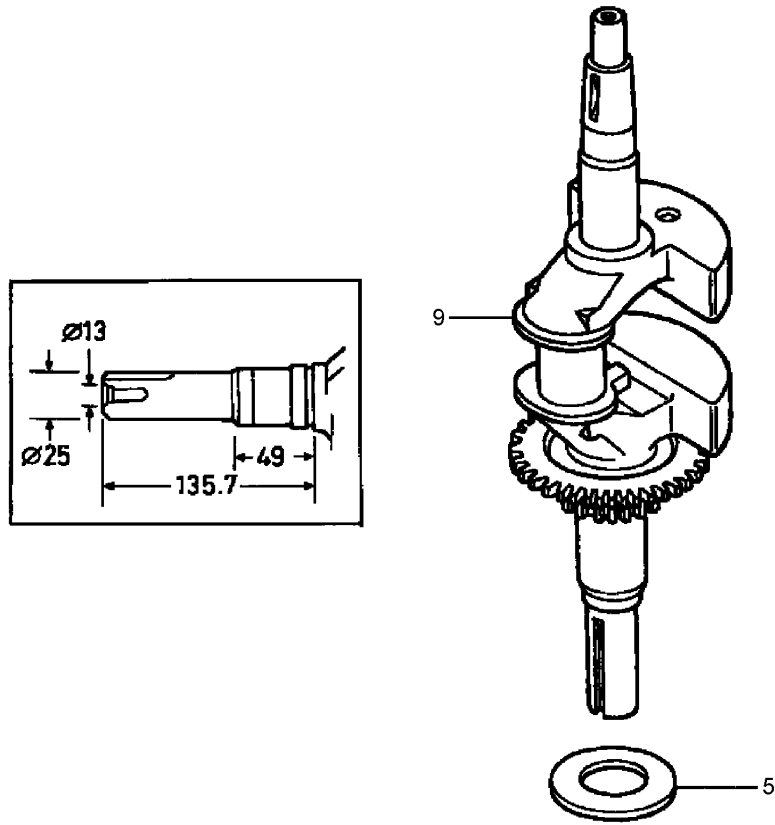

Crankshaft Assembly Honda GCV160A STL1

Ref	Part No.	Qty.	Description
5	90402-ZL8-000	1	Washer-Thrust
9	13310-Z0L-V70	1	Crankshaft

--	--	--	--

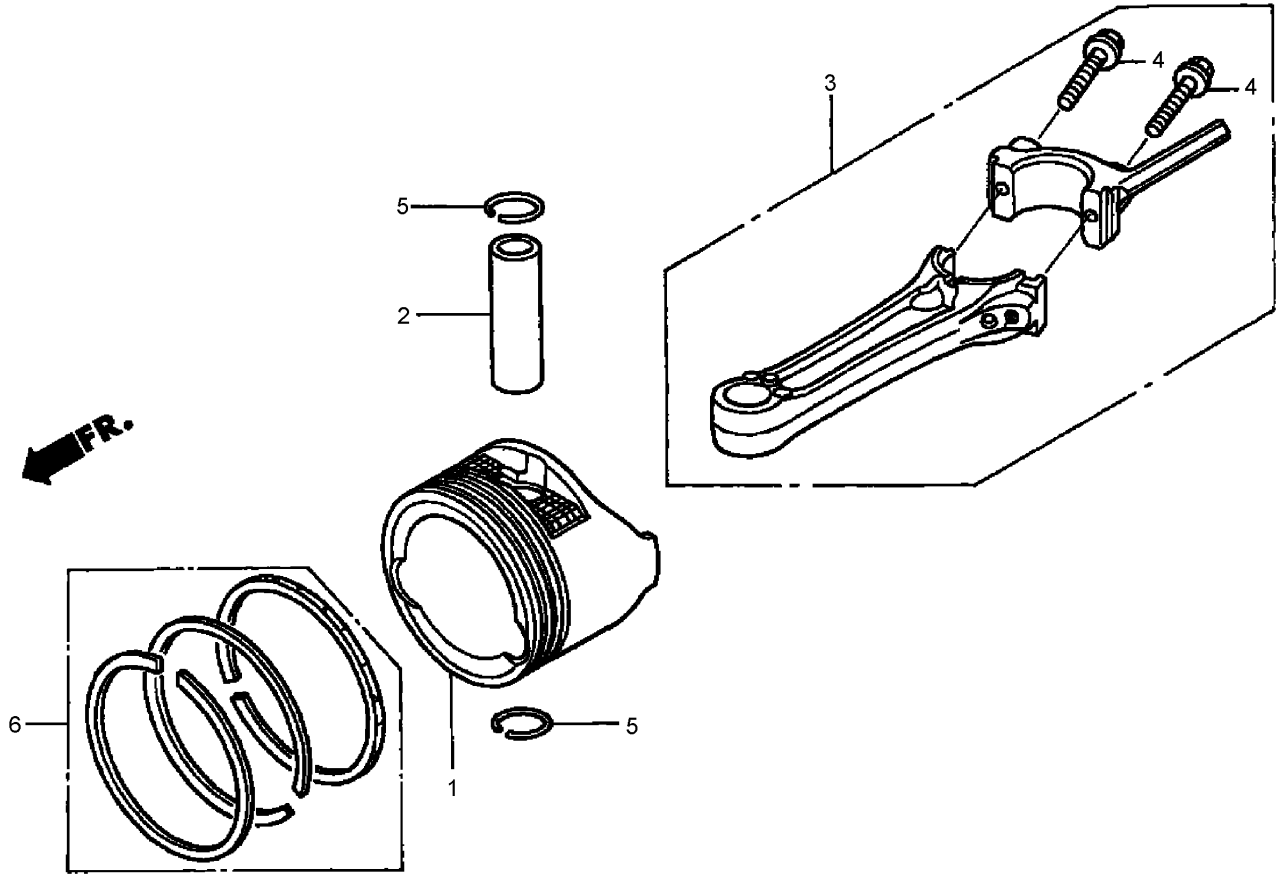

Piston and Connecting Rod Assembly Honda GCV160A STL1

Ref	Part No.	Qty.	Description
❶	13101-ZL8-000	1	Piston
❷	13111-ZE0-000	1	Pin-Piston
❸	13200-ZL8-000	1	Connecting Rod ASM
❹	90001-ZE1-000	2	Bolt-Rod, Connecting
❺	90551-ZE0-000	2	Clip-Pin, Piston (13Mm)
❻	13010-ZL8-003	1	Ring Set-Piston (Riken)
❻	13010-ZL8-024	1	Ring Set-Piston (Teikoku)

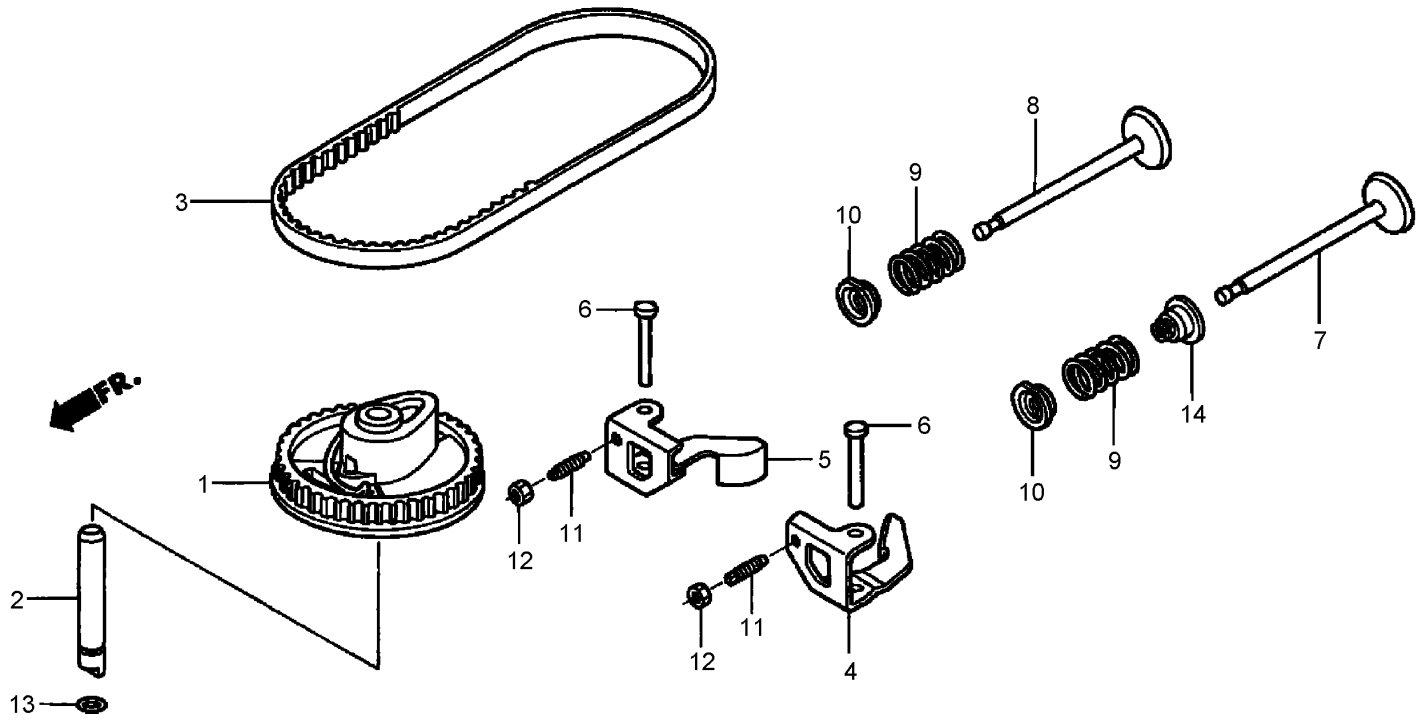

Camshaft Pulley Assembly Honda GCV160A STL1

Ref	Part No.	Qty.	Description
❶	14320-ZL8-010	1	Pulley-Camshaft
❷	14324-ZL8-000	1	Shaft-Pulley
❸	14400-Z0J-014	1	Belt-Timing (84Hu7 G-200)
❹	14431-Z0J-000	1	Rocker Arm-Valve, Intake
❺	14441-Z0J-000	1	Rocker Arm-Valve, Exhaust
❻	14461-ZL8-000	2	Shaft-Arm, Rocker
❼	14711-Z0J-000	1	Valve-Intake
❽	14721-ZL8-000	1	Valve-Exhaust
❾	14751-ZL8-000	2	Spring-Valve
❿	14771-Z0J-000	2	Retainer-Spring, Valve
⓫	90012-333-000	2	Screw-Tappet, Adj.
⓬	90206-001-000	2	Nut-Tappet, Adj.
Ⓜ	91301-ZM0-V31	1	O-Ring (6.8X1.9)

Ref	Part No.	Qty.	Description
Ⓨ	12209-ZM0-003	1	Seal-Stem, Valve

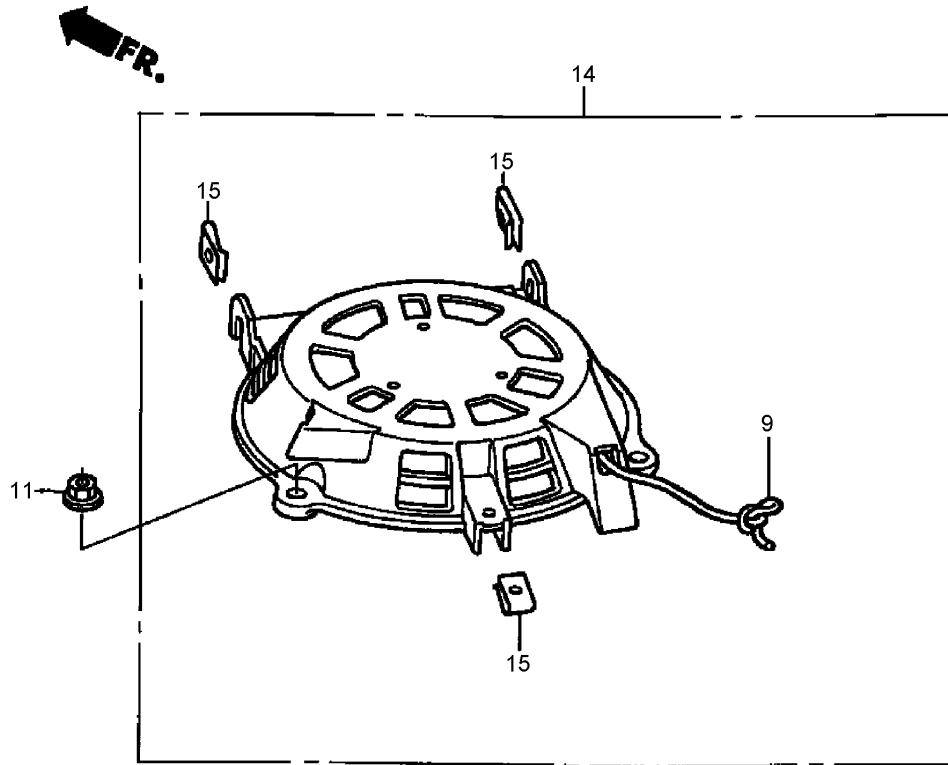

Recoil Starter Assembly Honda GCV160A STL1

Ref	Part No.	Qty.	Description				
9	28462-Z0L-V71	1	Rope-Starter, Recoil				
11	90201-ZM0-000	3	Nut-Flange (6Mm)				
14	28400-Z0L-V72	1	Recoil Starter ASM				
15	66871-KY2-700	3	Nut-Cowl				

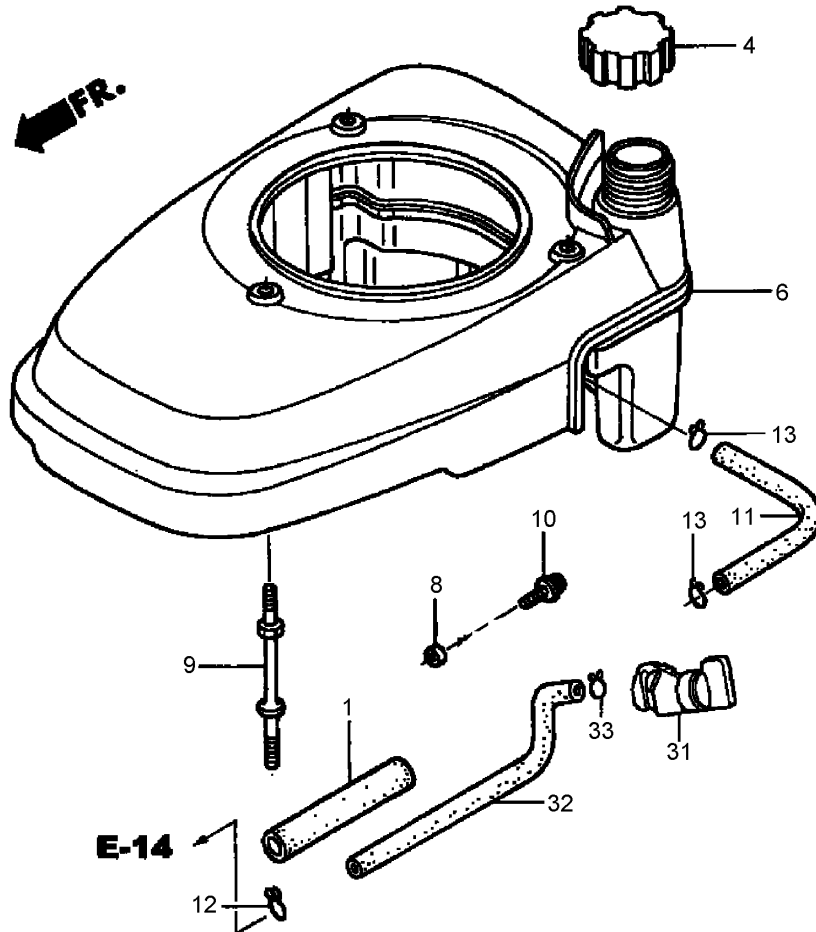

Fan Cover Assembly Honda GCV160A STL1

Ref	Part No.	Qty.	Description				
❶	16854-ZH8-000	1	Supporter-Rubber (107Mm)				
❷	17620-ZL8-013	1	Fuel Tank Cap ASM				
❸	19610-Z0L-800ZA	1	Cover-Fan				
❹	91501-Z0L-800	1	Collar-Petcock, Fuel				
❺	90043-ZL8-000	3	Bolt-Stud				
❻	93891-05010-08	1	Screw-Washer (5X10)				
❼	95001-55008-60M	1	Fuel-Hose (5.5X8000) (5.5X100)				
❽	95002-02080	1	Clip-Tube (B8)				
❾	95002-02100	2	Clip-Tube (B10)				
❿	16950-ZM0-003	1	Petcock ASM				
⓫	17702-ZM0-800	1	Tube- Fuel				
⓬	95002-02080	1	Clip-Tube (B8)				

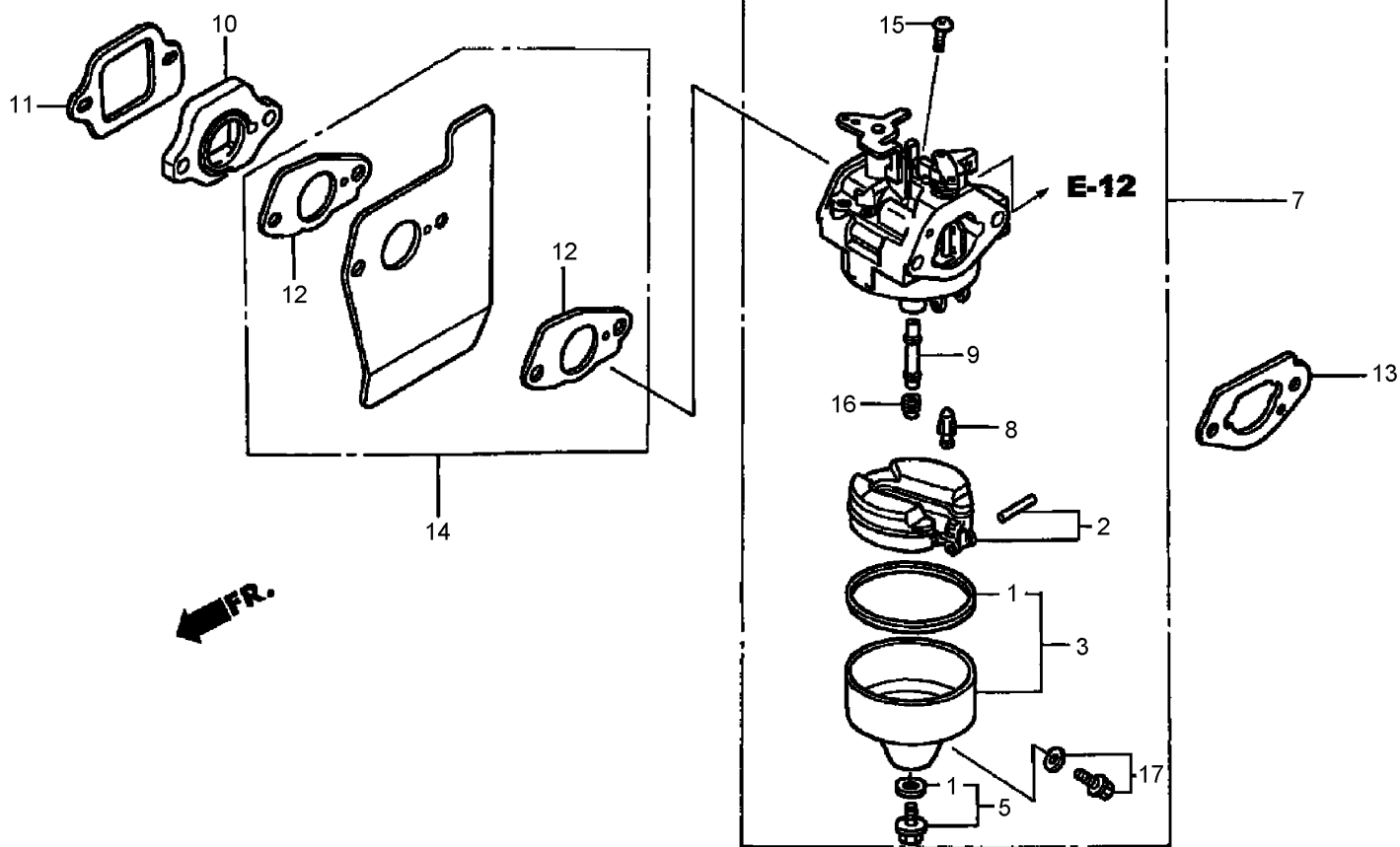

Carburetor Assembly Honda GCV160A STL1

Ref	Part No.	Qty.	Description
●1	16010-883-015	1	Gasket Set
●2	16013-ZL1-003	1	Float Set
●3	16015-887-782	1	Chamber Set-Float
●5	16028-ZE0-005	1	Screw-Set
●7	16100-Z0L-802	1	Carburetor ASM (Bb62G B)
●8	16155-ZM0-013	1	Valve-Float (Carburetor No.)
●9	16166-ZM0-003	1	Nozzle-Main
●10	16211-ZL8-000	1	Insulator-Carburetor
●11	16212-ZL8-000	1	Gasket-Insulator
●12	16221-883-800	2	Gasket-Carburetor
●13	16228-ZL8-000	1	Gasket-Carburetor (Choke Side)
●14	19650-ZM0-000	1	Guide-Air
●15	93500-05006-0H	1	Screw-Pan (5X6)

Ref	Part No.	Qty.	Description
●16	99101-124-0600	1	Jet-Main (#60)
●16	99101-124-0620	1	Jet-Main (#62)
●16	99101-124-0650	1	Jet-Main (#65)
●17	16024-ZE1-811	1	Screw Set-Drain

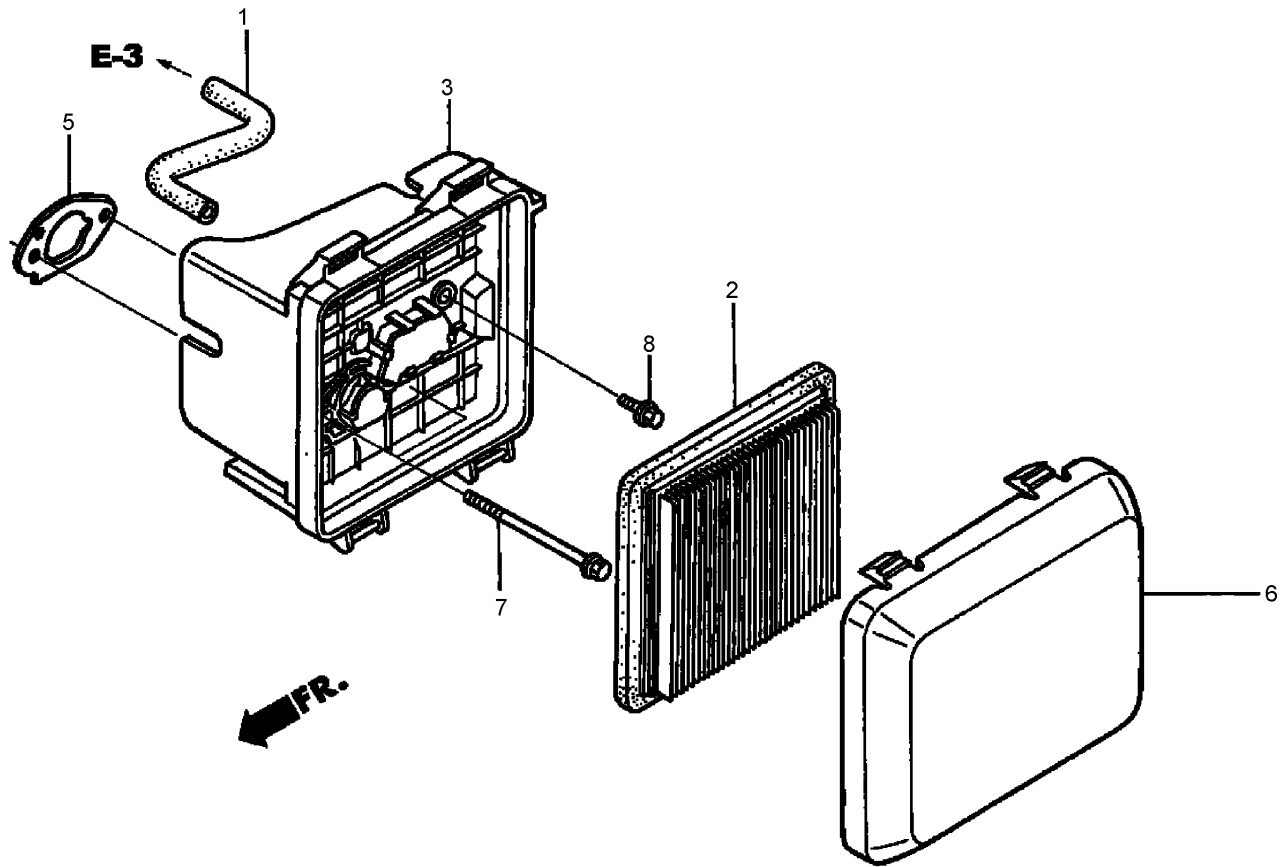

Air Cleaner Assembly Honda GCV160A STL1

Ref	Part No.	Qty.	Description
❶	15721-ZM0-000	1	Tube-Breather
❷	17211-ZL8-013	1	Element-Cleaner, Air
❸	17220-ZM0-000	1	Air Cleaner Case ASM
❺	17228-ZM0-000	1	Gasket-Cleaner, Air
❻	17231-Z0L-030	1	Cover-Cleaner, Air
❼	90003-ZM0-000	2	Bolt-Flange (6X86) (Ct200)
❽	95701-06014-08	1	Bolt-Flange (6X14)

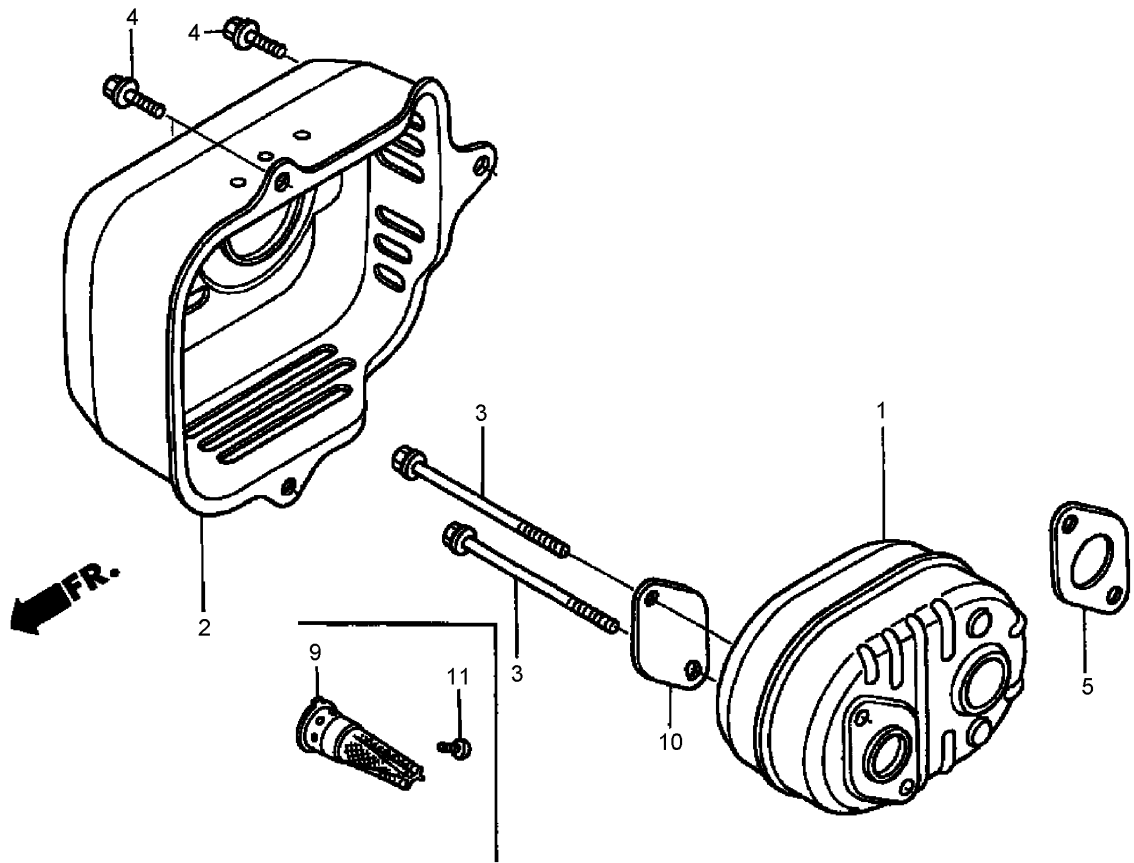

Muffler Assembly Honda GCV160A STL1

Ref	Part No.	Qty.	Description
❶	18310-ZM0-000	1	Muffler
❷	18321-Z0L-J00	1	Protector-Muffler (Cbu)
❸	90004-ZL8-000	2	Bolt-Flange (6X79) (Ct200)
❹	90013-883-000	3	Bolt-Flange (6X12) (Ct200)
❺	18381-ZL8-305	1	Gasket-Muffler
❾	18350-ZL8-000	1	Arrester-Spark
❿	18356-ZL8-000	1	Plate-Number, Arrester
⓫	90055-ZE1-000	1	Screw-Tapping (4X6)

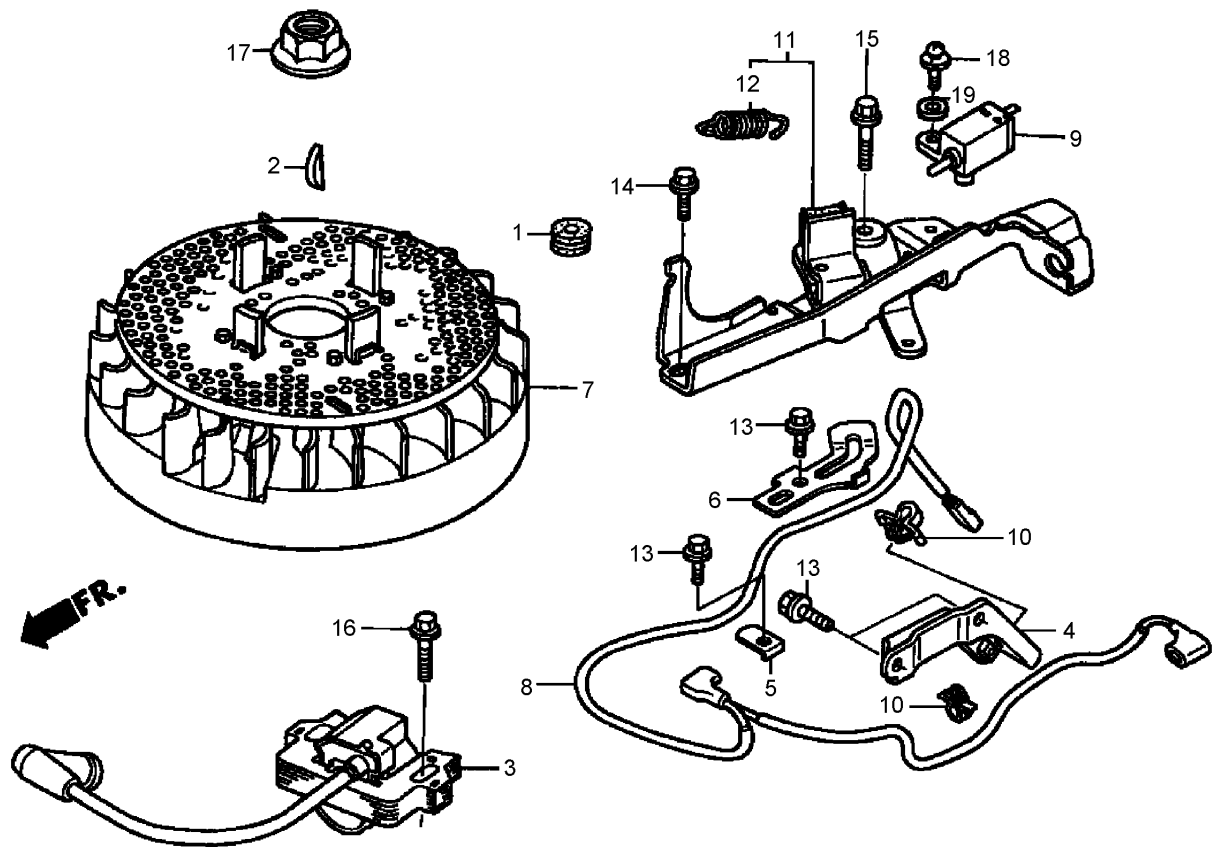

Flywheel Assembly Honda GCV160A STL1

Ref	Part No.	Qty.	Description
❶	11344-MB0-000	1	Grommet-Cover, A-Rr
❷	13331-357-000	1	Key-Woodruff (25X18)
❸	30500-ZL8-004	1	Ignition Coil ASM
❹	30547-Z0L-S00	1	Clamp-Wire, Stop Switch
❺	30548-ZL8-000	1	Clamp-Wire, Stop Switch
❻	30549-ZL8-000	1	Clamp-Wire
❼	31105-ZM0-000	1	Flywheel ASM
❽	32195-Z0L-S00	1	Wire-Switch, Stop
❾	35120-ZM0-003	1	Engine Stop Switch ASM
❿	51125-Z0L-003	2	Holder-Wire
❿	90681-959-003	2	Clip-Cable (A)
⓫	75110-Z0L-800	1	Brake Sub ASM
⓬	75113-ZM0-000	1	Spring-Lever, Brake

Ref	Part No.	Qty.	Description
⓭	90013-883-000	4	Bolt-Flange (6X12) (Ct200)
⓮	90014-952-000	1	Bolt-Flange (6X14)
⓯	90018-ZE1-000	1	Bolt-Flange
⓰	90022-888-010	1	Bolt-Flange (6X20)
⓱	90201-878-003	1	Nut (14Mm)
⓲	93892-04012-00	1	Screw-Washer
⓳	94103-04000	1	Washer-Plain

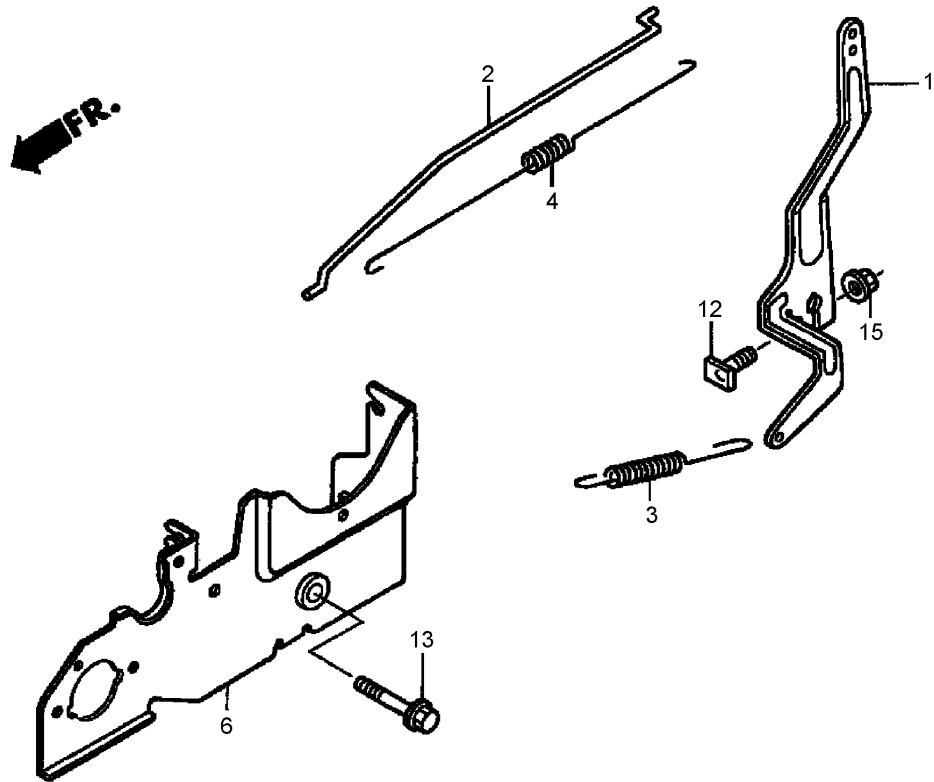

Control Assembly Honda GCV160A STL1

Ref	Part No.	Qty.	Description
❶	16551-ZM0-010	1	Arm-Governor
❷	16555-Z0L-800	1	Rod-Governor
❸	16561-Z0L-000	1	Spring-Governor
❹	16562-ZM0-000	1	Spring-Return, Throttle
❻	16580-Z0L-810	1	Base-Control
❸	90015-ZE5-010	1	Bolt-Arm, Governor
❹	90016-ZE8-000	1	Bolt-Flange (6X45)
❻	94050-06000	1	Nut-Flange (6Mm)

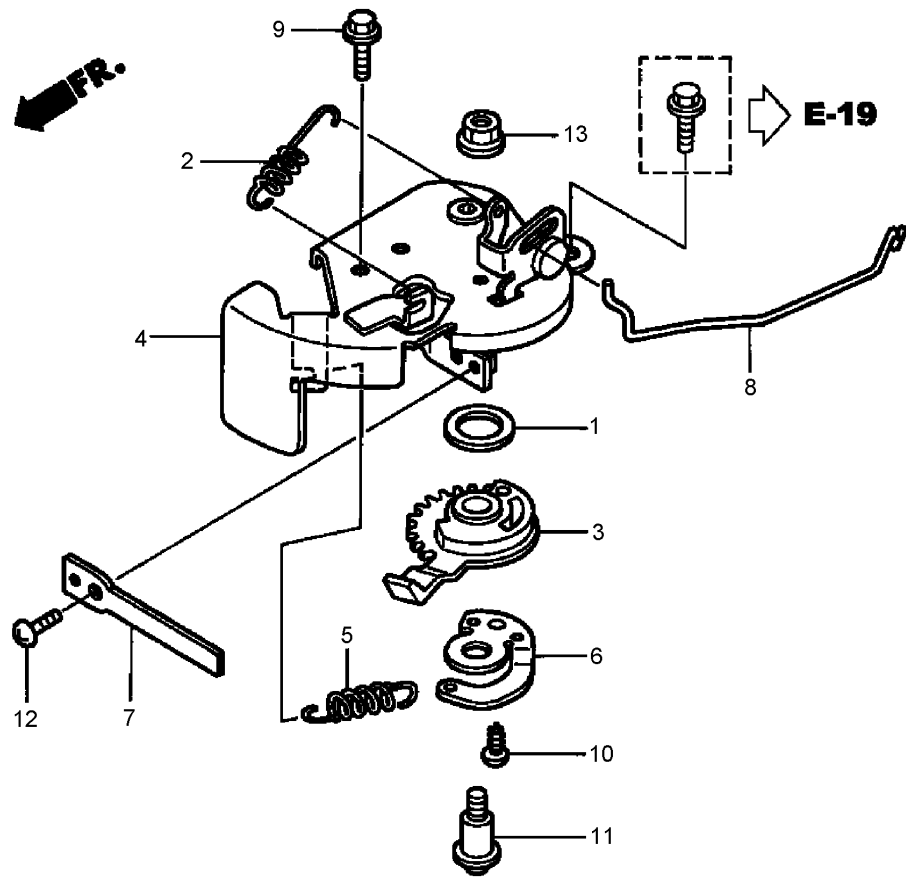

Choke Base Assembly Honda GCV160A STL1

Ref	Part No.	Qty.	Description				
❶	16251-Z0L-800	1	Seal-Lever, Choke				
❷	16592-ZJ1-000	1	Spring-Return, Cable				
❸	16612-Z0L-800	1	Lever-Choke				
❹	16613-Z0L-800	1	Base-Choke				
❺	16614-Z0L-800	1	Spring-Lever, Choke				
❻	16616-Z0L-800	1	Hook-Spring, Choke				
❼	16619-Z0L-800	1	Plate-Choke				
❽	16632-Z0L-800	1	Rod-Stop				
❾	90029-888-000	1	Bolt-Flange (6X16)				
❿	90102-SP1-003	1	Screw-Tapping (4X8) (Po)				
⓫	90141-KT8-000	1	Screw-Pan (5X19)				
⓬	93500-04008-0H	1	Screw-Pan (4X8)				
⓭	94050-05000	1	Nut-Flange (5Mm)				

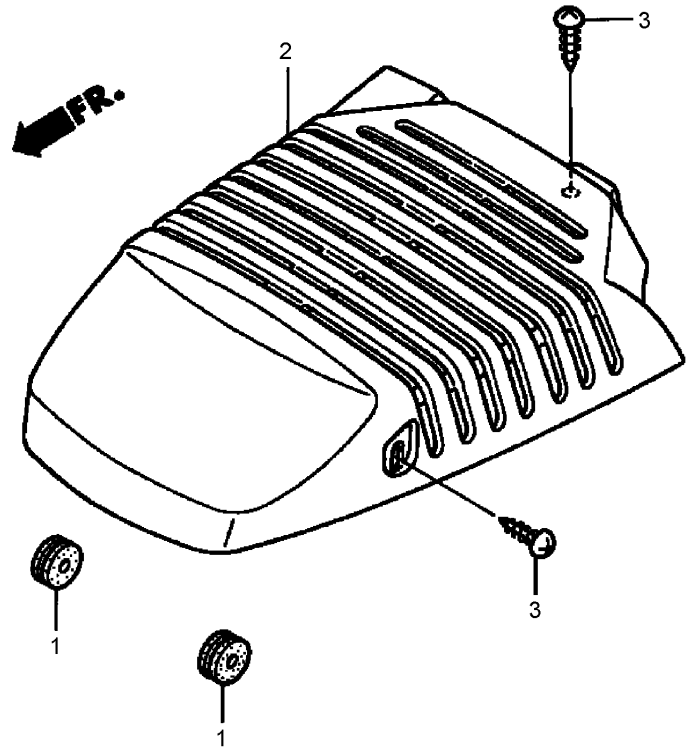

Top Cover Assembly Honda GCV160A STL1

Ref	Part No.	Qty.	Description
❶	16613-883-610	2	Grommet-Rod, Choke
❷	19721-Z0L-000ZA	1	Cover-Top
❸	90137-SH3-000	3	Screw-Tapping (4X16)

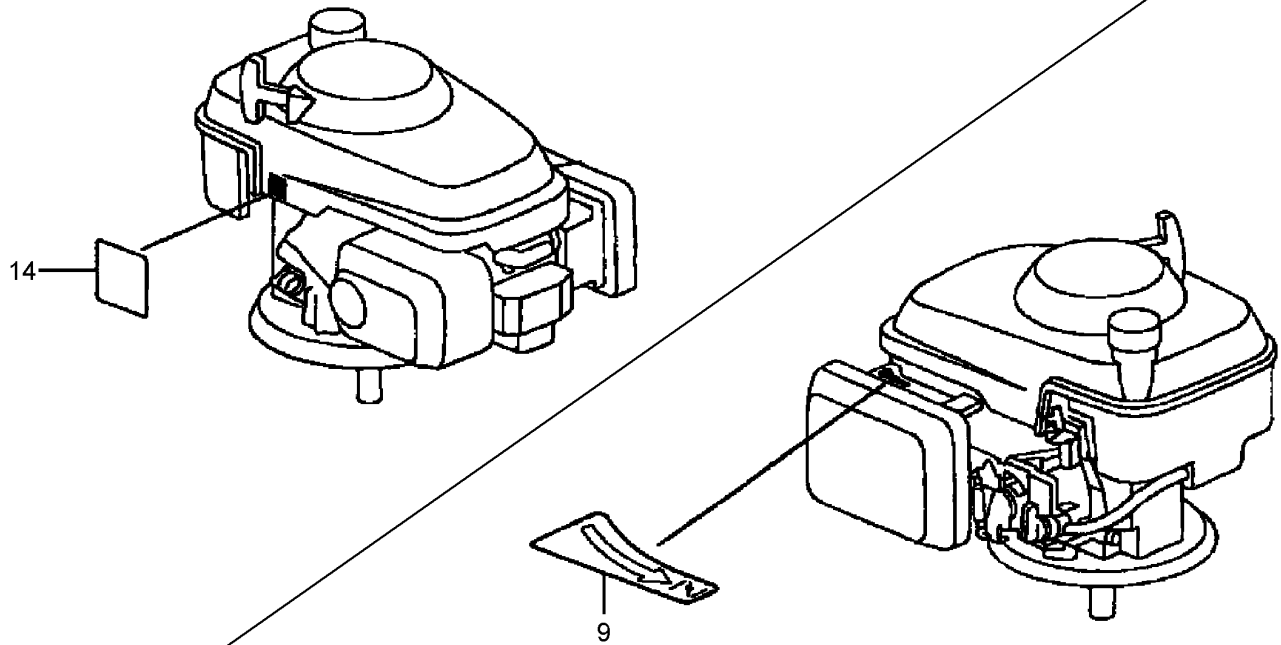

Label Assembly Honda GCV160A STL1

Ref	Part No.	Qty.	Description				
●9	87528-Z0L-V20	1	Mark-Indication, Choke				
●14	87594-VG3-010	1	Mark-Caution, Oil				

Attachments and Accessories

For 10695 - Insight Gold Lawn Mower

Product Name	Model/Part
Lawn Boy Paint	110-8800
Height-of-Cut Kit	110-8801
Replacement Bag	89815
Rear Bag Kit	89913
21 Inch Blade	89914
Cruise Control Kit	89919
Air Filter	89928
Spark Plug	89947
Cup Holder	89951

NOTES

