



Insight[®] Lawn Mower

Model No. 10685 - 270000001 and up.

Parts Catalog

Ordering Replacement Parts

To order replacement parts, please supply the part number, the quantity, and the description of each part desired.

Understanding Reference Numbers

Each identified part in an illustration has a reference number. The reference number for a part also appears in the parts list, along with other information about the part.

This catalog uses two special reference number formats, one to indicate parts in a service assembly and another to indicate the quantity of a given part in an illustration.

Service Assembly Reference Numbers

Parts in service assemblies have reference numbers in the form a:b. The a represents the reference number of the entire service assembly and the b represents a sequential number unique to each part within the service assembly.

For example, a wheel assembly might be identified by reference number 6, the tire by 6:1, the valve by 6:2, and the wheel by 6:3. When you order the assembly identified by reference number 6, you receive all parts identified by reference numbers 6:1, 6:2, and 6:3. However, you may also order any part individually. Reference numbers of this type appear in illustrations and in part lists.

Reference Numbers Indicating Quantity

In an illustration, if a reference number indicates more than one part, the reference number has the form nX y. The n represents the quantity of the part, the X is the multiplication symbol, and the y represents the reference number.

For example, in an illustration, the reference number 2X 37 means that two of the parts identified by reference number 37 are indicated.

Contents

Description	Page	Description	Page
Front End and Tunnel Assembly 3	Carburetor Assembly No. 640350 Tecumseh LV195EA-362044D 11
Housing Assembly No. 108-9346 4	Engine Assembly No. 1 Tecumseh LV195EA-362044D 12
Rear Axle and Transmission Assembly 5	Engine Assembly No. 2 Tecumseh LV195EA-362044D 14
Transmission Assembly No. 107-3860 6	Recoil Starter Assembly No. 590739 Tecumseh LV195EA-362044D 16
Upper Handle Assembly 7	Recoil Starter Assembly No. 590702 (optional) Tecumseh LV195EA-362044D 17
Lower Handle Assembly 8	Attachments and Accessories List 18
Blade and Engine Assembly 9		
Rear Bag Assembly 10		

Part Description Abbreviations

Part descriptions in this catalog may include the following abbreviations.

AR. as required	HYD. hydraulic
ASM. assembly	LH. left hand
BBC. blade brake clutch	NI. nylon insert
CARR. carriage	NPTF. national pipe thread fine
DEG. degrees	PFH. phillips flat head
EXT. external	PPH. phillips pan head
FH. flat head	PPHTF. phillips pan head thread forming
GA. gauge	PRH. phillips round head
HD. heavy-duty	PTH. phillips truss head
HF. hex flange	PTO. power-take-off
HH. hex head	RH. right hand
HHF. hex head flange	ROPS. roll-over protection system
HHFTF. hex head flange thread forming	SFH. slotted fillister head
HJ. hex jam	SHH. slotted hex head
HLH. hex lag head	SHWH. slotted hex washer head
HOC. height-of-cut	SPH. slotted pan head
HSBH. hex socket button head	SQH. square head
HSFH. hex socket flat head	SRH. slotted round head
HSH. hex socket head	STD. standard
HWH. hex washer head	TAP. self tapping
HWHTF. hex washer head thread forming	TTH. torx truss head

Footnotes

- ❶ Not illustrated
- ❷ Not serviced separately
- ❸ Obtain from your local Tecumseh dealer

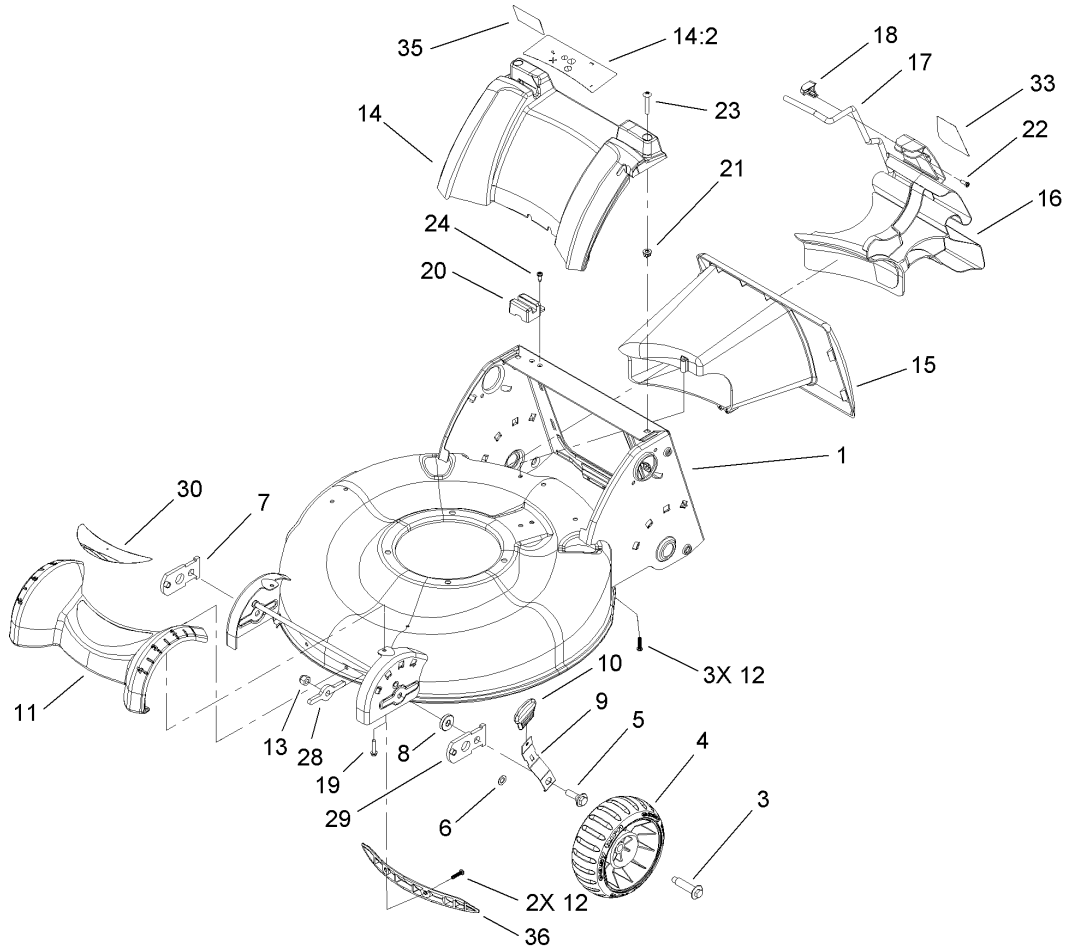

Front End and Tunnel Assembly

Ref	Part No.	Qty.	Description
1	108-9346	1	Housing ASM
3	614650	2	Bolt-Shoulder
4	112-1548	2	7 Inch Front Wheel ASM
5	614672	2	Bolt-Shoulder
6	40-1940	2	Washer
7	107-3877	1	Arm-Pivot, RH
8	92-4890	2	Washer
9	107-3878	2	Arm-Spring
10	107-1904	2	Knob-Lever, HOC
11	107-3926	1	Cover-Front
12	108-7476	5	Screw-Plastite
13	3296-39	2	Nut-Lock, NI
14	108-9349	1	Cover-Rear
14:2	107-3888	1	Decal-Safety
15	110-9455	1	Tunnel
16	107-3907	1	Plug-Chute
17	108-1038	1	Latch-Plug
18	108-0956	1	Retainer-Latch
19	108-7475	2	Screw-Plastite
20	108-0967	1	Module-Switch
21	94-1610	2	Nut-Clip
22	32144-111	1	Screw-PPH
23	108-0965	2	Screw-PTH
24	105-6849	2	Screw-Thread Forming

Ref	Part No.	Qty.	Description
28	108-1048	2	Washer-Support, Front
29	108-1044	1	Arm-Pivot, LH
30	108-7453	1	Decal
33	108-7461	1	Decal
35	107-1938	1	Decal-Bag Attachment
36	108-7502	1	Insert-Housing
39	110-1751	1	Mulch Plug ASM

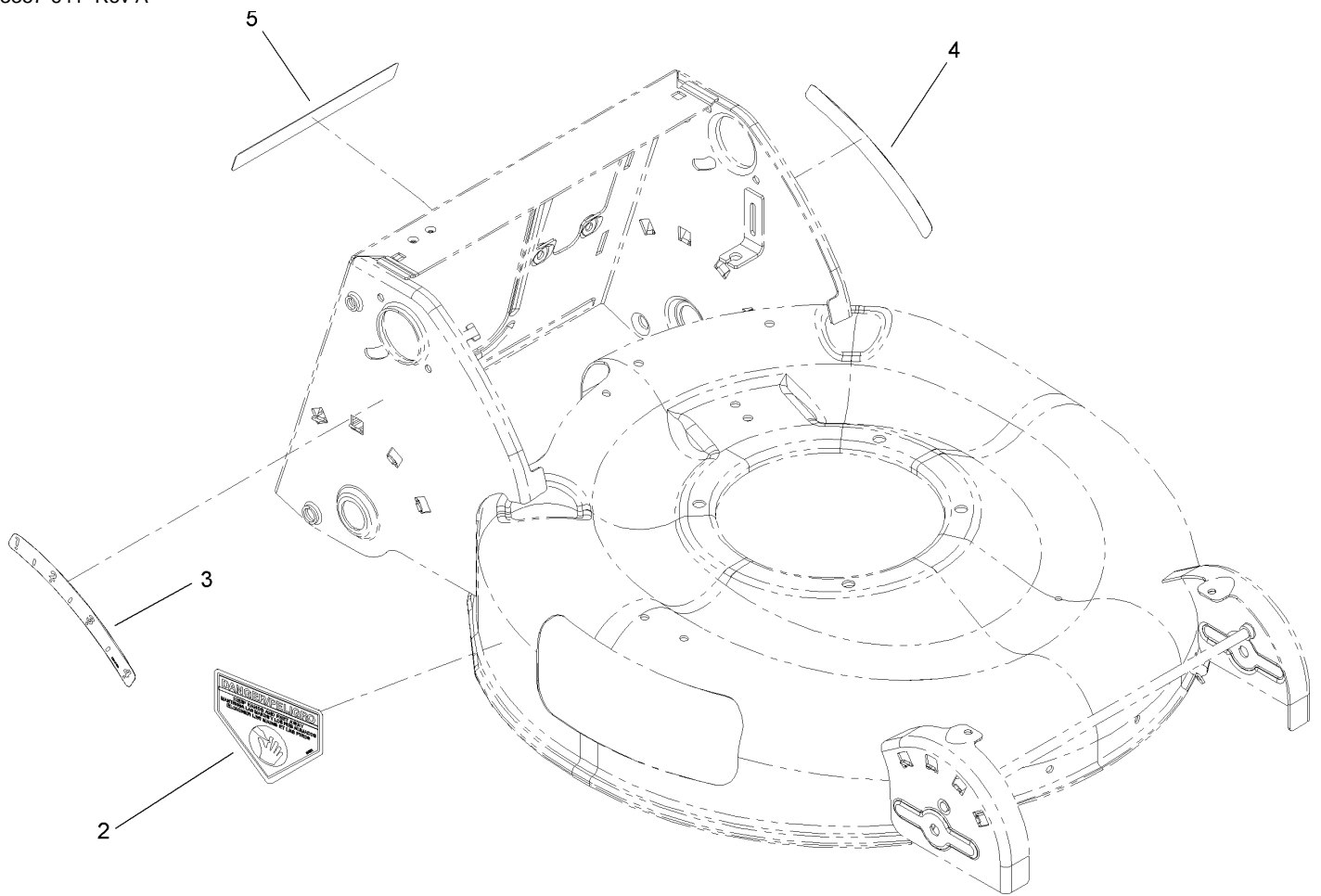

Housing Assembly No. 108-9346

Ref	Part No.	Qty.	Description
2	94-8072	1	Decal-Danger,
3	108-7450	1	Decal-HOC, RH
4	108-7451	1	Decal-HOC, LH
5	107-3889	1	Decal-Safety

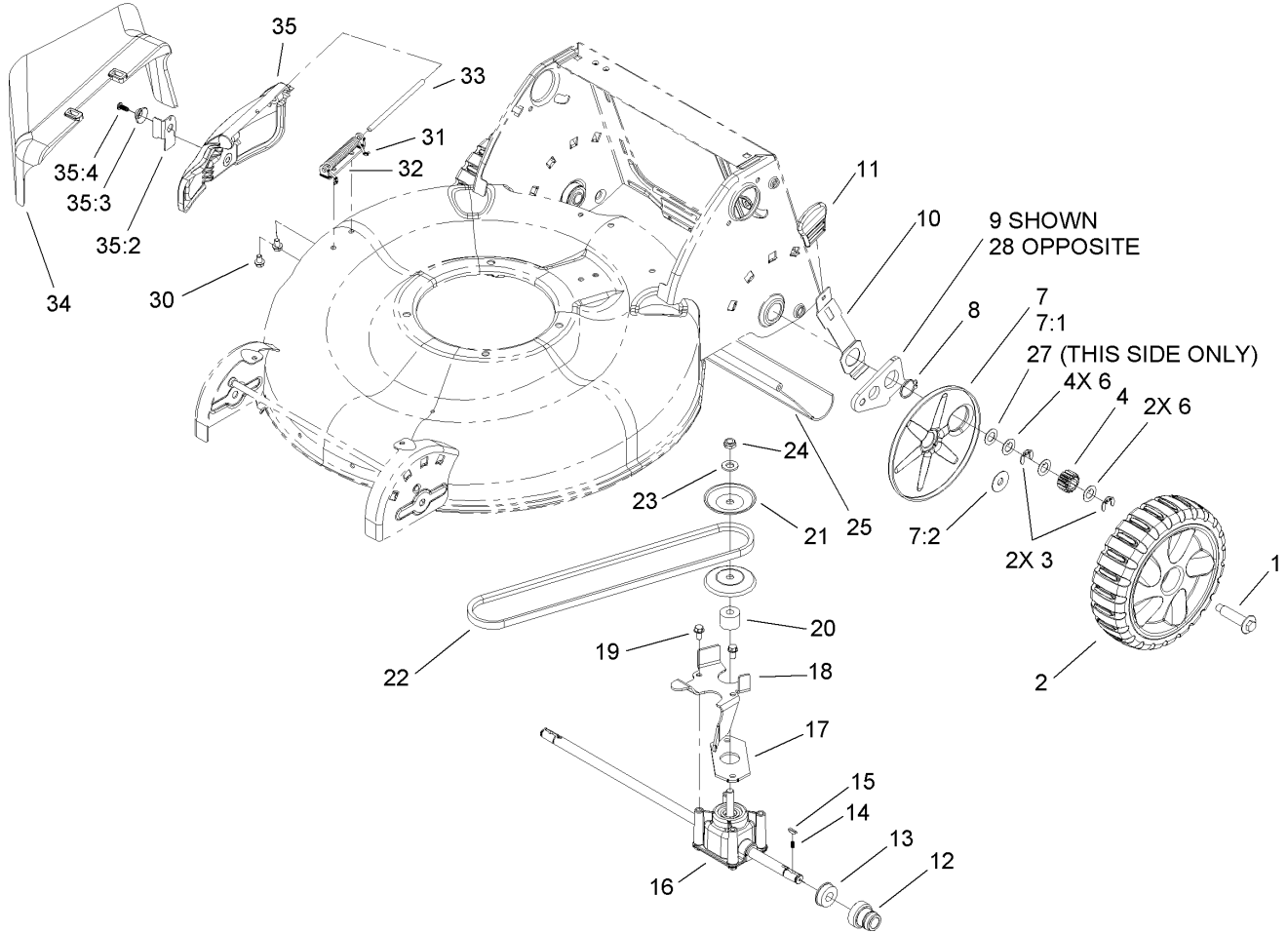

Rear Axle and Transmission Assembly

Ref	Part No.	Qty.	Description
1	614650	2	Bolt-Shoulder
2	107-3906	2	Rear Wheel ASM
3	65-2720	4	Klipring-Locking
4	105-3040	2	Gear-Pinion, 15T
6	105-6840	6	Washer-Thrust
7	110-1793	2	Wheel Cover ASM
7:1		1	Cover-Wheel
7:2	614426	1	Washer-Stepped
8	32151-36	2	Ring-Retaining
9	108-9344	1	Arm-Rear Pivot, LH
10	110-9445	2	Arm-Spring, Rear
11	107-1904	2	Knob-Lever, HOC
12	104-8698	2	Retainer-Bearing, HOC
13	104-8699	2	Bearing-Ball
14	39-9650	2	Spring-Compression
15	612066	2	Key
16	107-3860	1	Transmission ASM
17	108-9756	1	Gasket-Gearbox
18	107-3884-03	1	Bracket-Transmission
19	32144-4	2	Screw-HWH
20	92-5791	1	Spacer
21	100-1176	2	Pulley-Half
22	91-2258	1	V-Belt
23	3256-24	1	Washer-Flat

Ref	Part No.	Qty.	Description
24	3296-5	1	Nut-Lock
25	107-3904	1	Shield-Trailing
27	36-4780	1	Washer
28	108-9343	1	Arm-Rear Pivot, RH
30	99-8445	2	Screw-HWH
31	99-5293	1	Spring-Torsion
32	112-6416	1	Bracket-Cover
33	99-5291	1	Rod-Cover
34	105-3028	1	Chute-Discharge, Side
35	106-8376	1	Discharge Door ASM
35:2	107-0795	1	Latch-Door
35:3	107-7456	1	Cap-Door
35:4	107-7461	1	Screw-Plastite

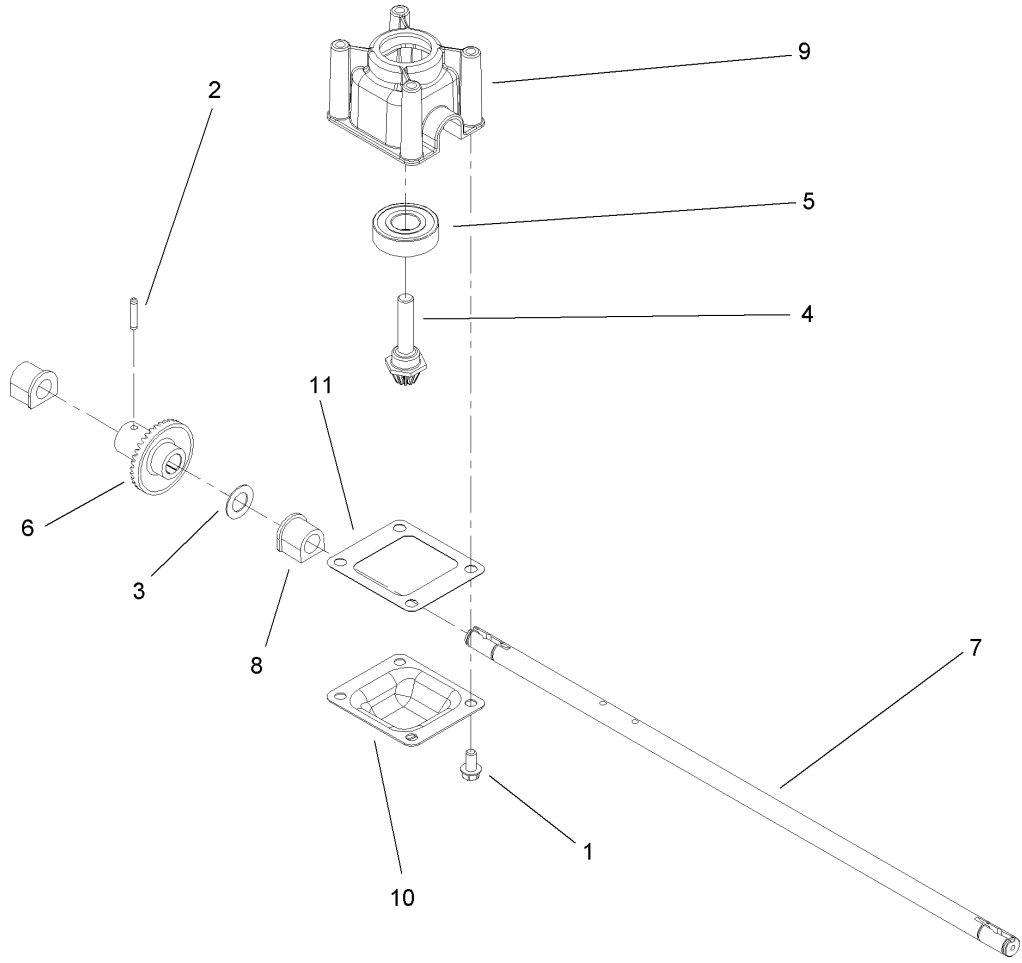

Transmission Assembly No. 107-3860

Ref	Part No.	Qty.	Description
1	32144-4	4	Screw-HWH
2	3285-19	1	Pin-Groove
3	36-4780	1	Washer
4	92-5790	1	Pinion
5	100-1048	1	Bearing-Ball
6	104-8671	1	Gear-Bevel, 37T
7	107-3861	1	Shaft-Output
8	104-8673	2	Bushing-Shaft, Output
9	104-8674	1	Gearcase-Upper
10	104-8675-03	1	Cover-Gearcase
11	105-6839	1	Gasket-Gearcase

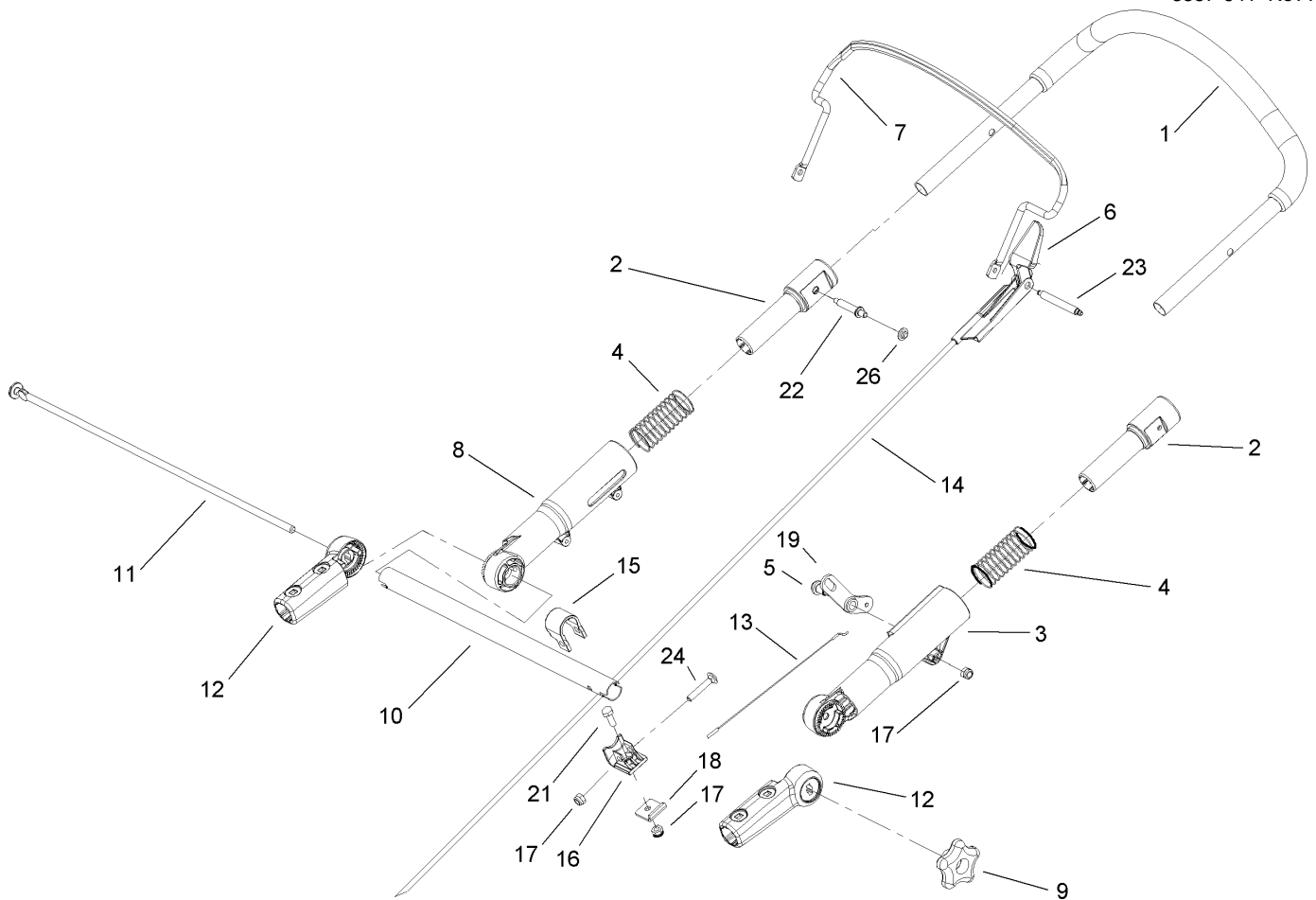

Upper Handle Assembly

Ref	Part No.	Qty.	Description
1	108-0974	1	Upper Handle ASM
2	112-8754	2	Sleeve Inner
3	112-1544	1	Sleeve Outer, LH
4	107-3869	2	Spring-Compression
5	104-0858	1	Bolt-Shoulder
6	112-8764	1	Stop-Pivot
7	110-1819-03	1	Bail-Brake
8	112-1545	1	Sleeve Outer, RH
9	107-3937	1	Knob
10	107-3867-03	1	Tube-Cross
11	107-3871	1	Rod-Threaded
12	107-3865	2	Mount-Handle, Lower
13	107-3902	1	Cable-Traction
14	108-0963	1	Cable-Brake
15	108-1045	1	Support-Cable
16	108-1046	1	Support-Guide, Cable
17	3296-73	3	Nut-Lock, NI
18	108-7454	1	Clamp-Cable
19	107-3893	1	Lever-Traction
21	321-4	1	Screw-HH
22	108-0959	1	Pin-Handle
23	108-1008	1	Pin-Bail, LH
24	108-0988	1	Screw-CARR
26	108-9378	1	Retainer-Push On

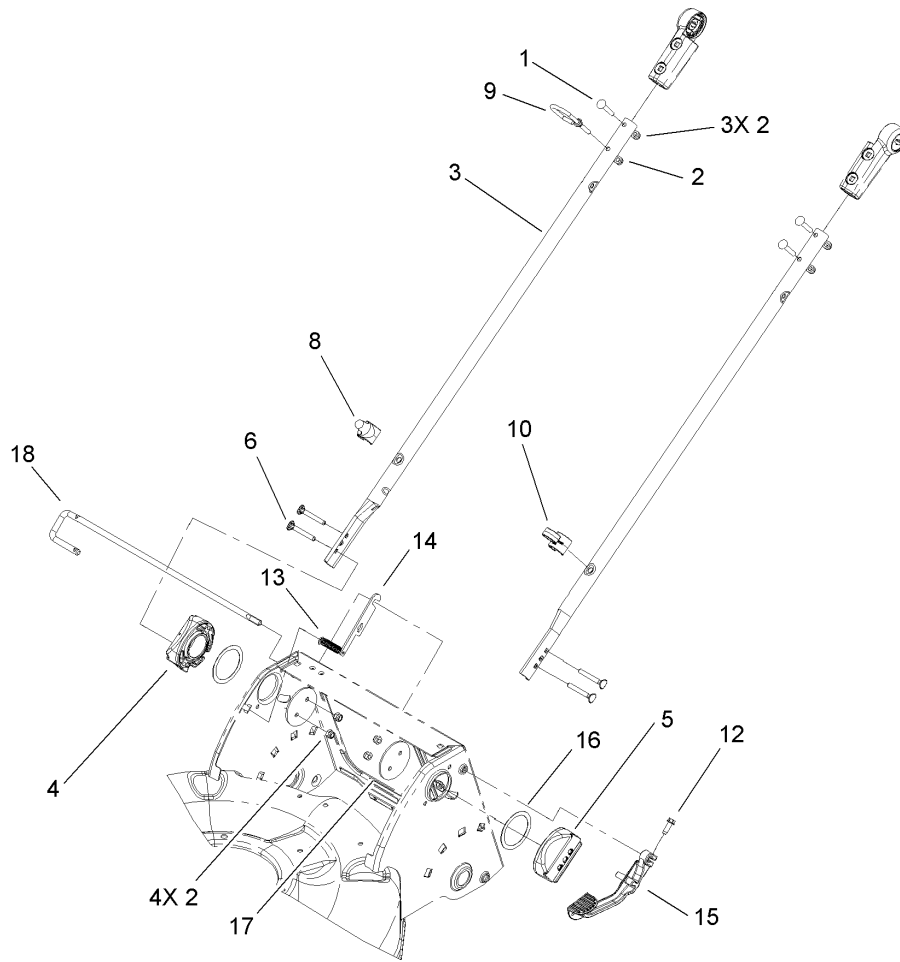

Lower Handle Assembly

Ref	Part No.	Qty.	Description				
1	108-0988	3	Screw-CARR				
2	3296-73	8	Nut-Lock, NI				
3	107-3887-03	2	Tube-Lower				
4	108-9339-03	1	Mount-Handle, RH				
5	108-9340-03	1	Mount-Handle, LH				
6	95-4453	4	Screw				
8	108-0994	1	Guide-Rope, Lower				
9	107-3908	1	Guide-Rope, Upper				
10	106-6805	1	Guide-Cable				
12	49-2040	1	Screw-HWHTF				
13	112-1542	1	Spring-Extension				
14	112-1539	1	Plate-Release Rod				
15	110-1823-03	1	Lever-Release				
16	107-3947	2	Washer-Nylon				
17	107-3944-03	2	Plate				
18	112-8755	1	Handle-Rod, Release				

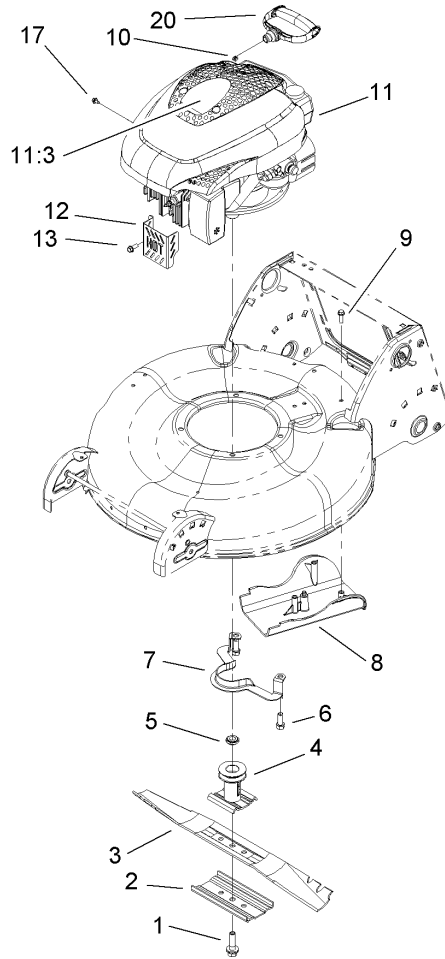

Blade and Engine Assembly

Ref	Part No.	Qty.	Description				
1	105-8579	1	Bolt-Blade				
2	108-3766-03	1	Support-Blade				
3	108-0954-03	1	Blade-21 Inch				
4	106-3987	1	Blade Driver ASM				
5	106-3999	1	Spacer-Driver				
6	92-1624	3	Screw				
7	105-3030-03	1	Guide-Belt				
8	110-1832	1	Cover-Belt				
9	46-8091	3	Screw-HWH				
10	92-1701	1	Stop-Rope				
11		1	Engine-Tecumseh, Lv195Ea-362044D				
11:3	108-7452	1	Decal-Recoil				
12	106-8346-03	1	Guard-Muffler				
13	32144-85	1	Screw-HWH				
17	98-1394	1	Screw-HWH				
20	110-1778	1	Handle-Recoil				

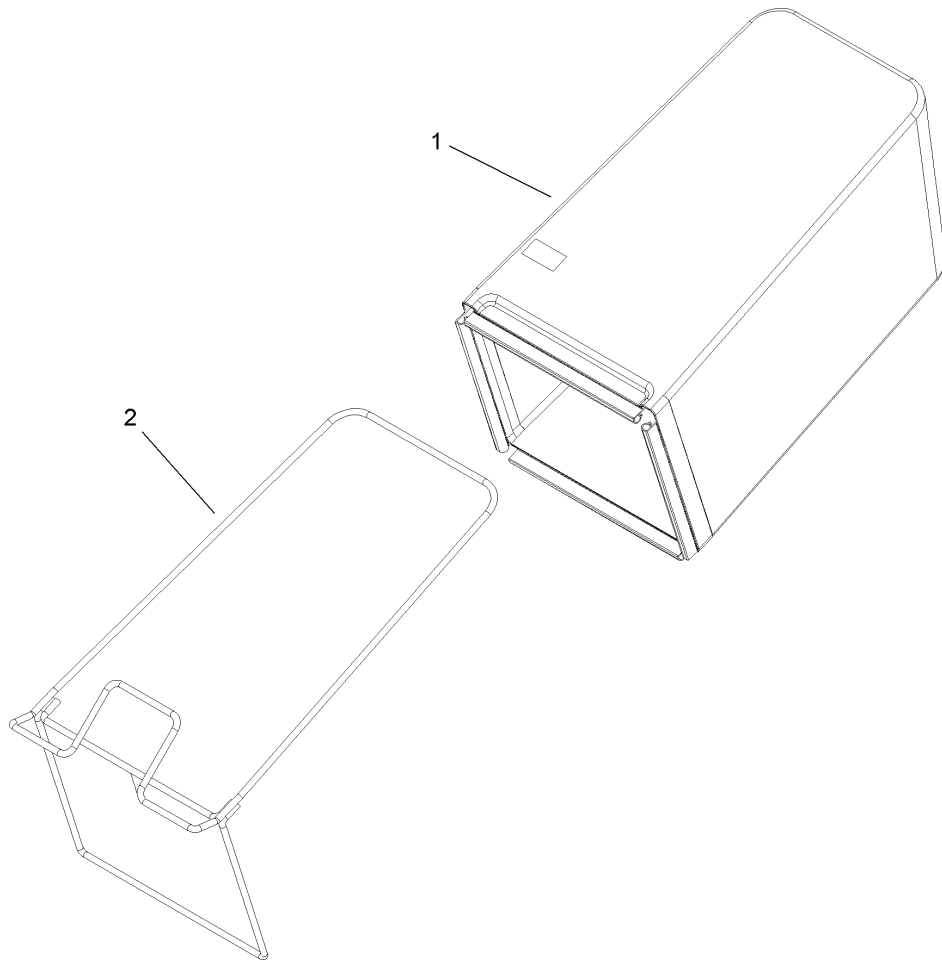

Rear Bag Assembly

Ref	Part No.	Qty.	Description
1	107-3911	1	Bag-Grass
2	107-3912-03	1	Bag Frame ASM

--	--	--	--

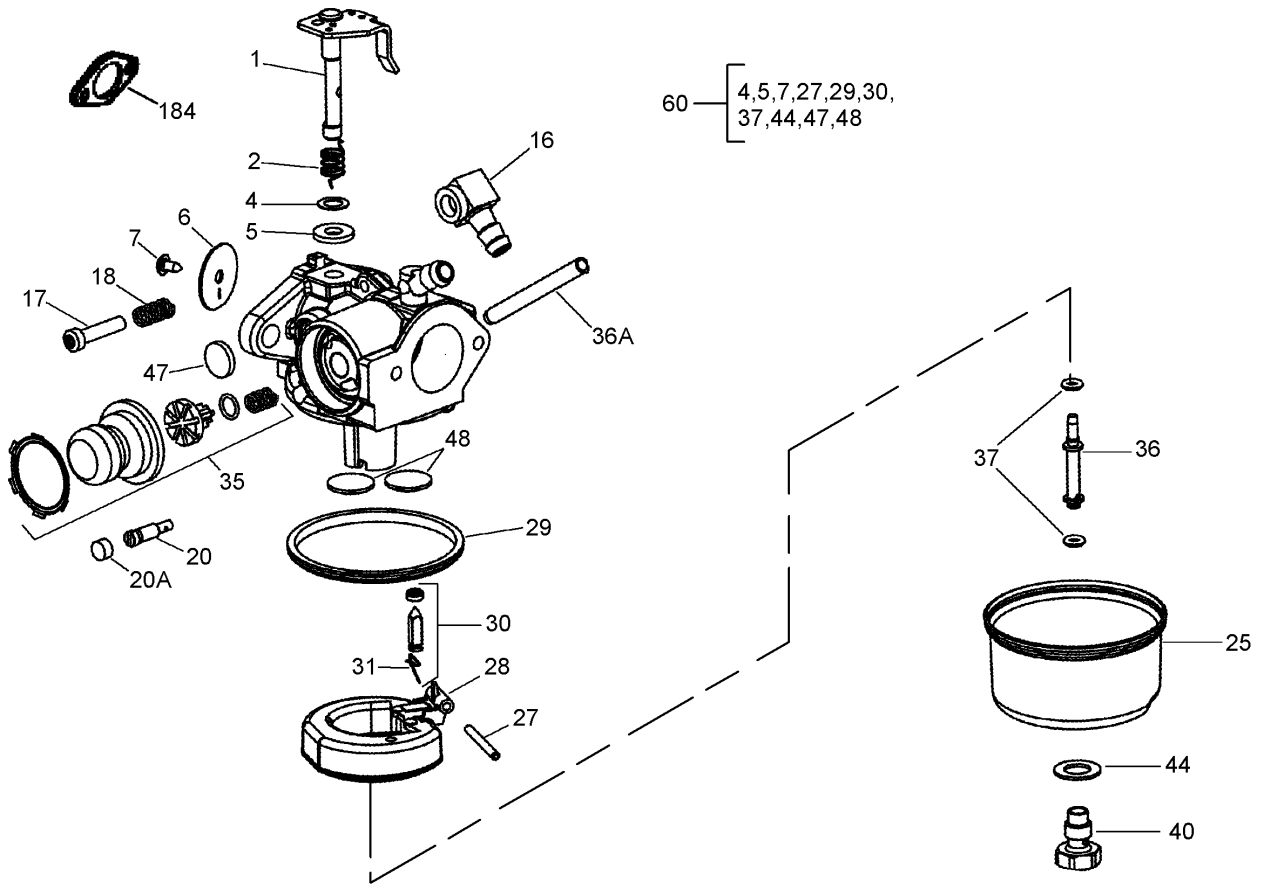

Carburetor Assembly No. 640350 Tecumseh LV195EA-362044D

Ref	Part No.	Qty.	Description
❶	631615	1	Throttle Shaft And Lever ASM
❷	631767	1	Spring-Return, Throttle
❸	631184	1	Washer-Seal, Dust
❹	631183	1	Dust Seal (Throttle)
❺	640070	1	Shutter-Throttle
❻	650506	1	Screw-Shutter
❼	631807	1	Fitting-Fuel
❽	651025	1	Screw-Throttle Crack/Idle Speed
❾	630766	1	Spring-Tension
❿	640016	1	Screw-Restrictor, Idle
⓫	640200	1	Cap-Screw, Restrictor Idle
⓬	631867	1	Bowl-Float (No Drain)
⓭	631024	1	Shaft-Float
⓮	632802	1	Float (Plastic)
⓯	631028	1	O-Ring-Bowl, Float
⓰	631021A	1	Inlet Needle, Seat, And Clip ASM (Includes 31)
⓱	631022	1	Clip-Spring
⓲	640351	1	Primer Bulb/Valve Repair Kit
⓳	640080	1	Tube-Nozzle, Main
⓴	632766	1	Tube-Carburetor
⓵	632547	2	O-Ring-Nozzle Tube, Main
⓶	640030	1	Nut-Bowl, High Speed
⓷	27110A	1	Washer-Nut, Bowl

Ref	Part No.	Qty.	Description
⓸	630748	1	Plug-Welch, Idle Mixture Well
⓹	631027	2	Plug-Welch, Atmospheric Vent
⓺	632760B	1	Repair Kit (Includes 4, 5, 7, 27, 29, 30, 37, 44, 47, 48)
⓻	26756	1	Gasket-Carburetor To Intake Pipe

Engine Assembly No. 1

Tecumseh LV195EA-362044D

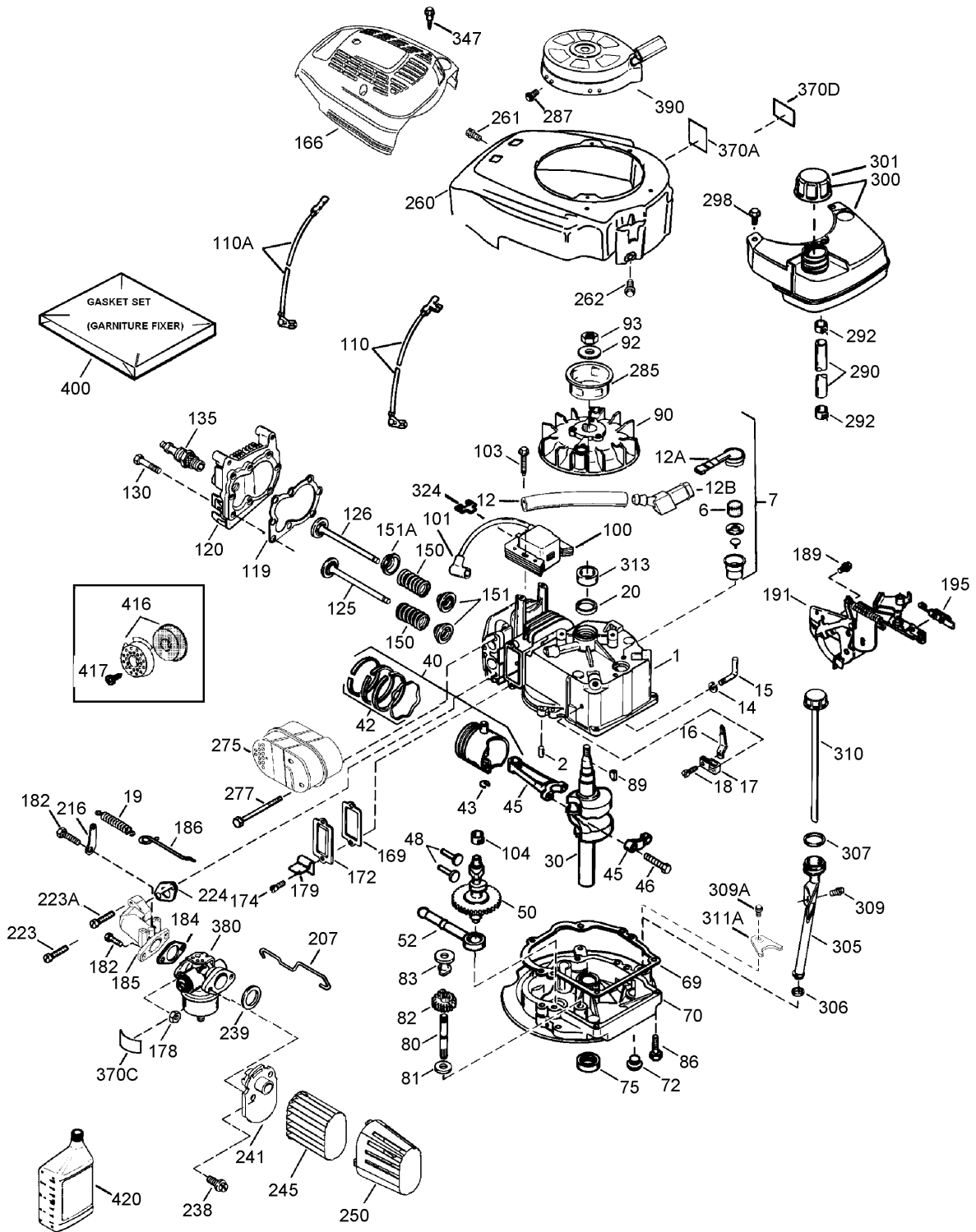

Engine Assembly No. 1

Tecumseh LV195EA-362044D

Ref	Part No.	Qty.	Description	Ref	Part No.	Qty.	Description
①1	37465	1	Cylinder (Includes 2, 20, 150)	①130	6021A	8	Screw (5/16-18X1-1/2)
①2	26727	2	Pin-Dowel	①135	35395	1	Spark Plug-Resistor (R J19 L M)
①6	33734	1	Element-Breather	①150	31672	2	Spring-Valve
①7	36557	1	Breather ASM (Includes 6, 12A)	①151	31673	2	Cap-Valve, Spring
①12	37944	1	Tube-Breather	①151A	40017	1	Seal-Valve, Intake
①12A	36558	1	Breather Cover And Tube ASM (Includes 12B)	①166	37813A	1	Shroud-Engine (Green)
①12B	36694	1	Elbow-Tube, Breather	①169	36783	1	Gasket-Cover, Valve
①14	28277	1	Washer-Flat	①172	36784	1	Cover-Valve
①15	30589	1	Rod-Governor (Includes 14)	①174	30200	2	Screw (10-24 X 9/16)
①16	34839A	1	Lever-Governor	①178	29752	2	Nut And Lock Washer (1/4-28)
①17	31335	1	Clamp-Lever, Governor	①179	30593	1	Retainer Clip
①18	651018	1	Screw (T-15, 8-32 X 19/64)	①182	6201	2	Screw (1/4-28 X 7/8)
①19	36281	1	Spring-Extension	①184	26756	1	Gasket-Carburetor To Intake Pipe
①20	32600	1	Seal-Oil	①185	37466	1	Pipe-Intake
①30	37692	1	Crankshaft	①186	32653	1	Link-Governor
①40	40027	1	Piston, Pin And Ring Set (STD.)	①189	650839	2	Screw (1/4-20 X 3/8)
①42	40006	1	Ring Set (STD)	①191	36559A	1	Bracket-Brake (Includes 195)
①43	20381	2	Ring-Retaining, Piston Pin	①195	610973	1	Terminal
①45	36777	1	Connecting Rod ASM (Includes 46)	①207	34336A	1	Link-Throttle
①46	32610A	2	Bolt-Rod, Connecting	①216	33086	1	Lever-Adjusting, Rpm
①48	27241	2	Lifter-Valve	①223	650451	1	Screw (1/4-20 X 1)
①50	37460	1	Camshaft (Includes 104)	①223A	651074	1	Stud-Pipe, Intake
①52	29914	1	Oil Pump ASM	①224	36786	1	Gasket-Pipe, Intake
①69	37609	1	Gasket-Flange, Mounting	①238	650932	2	Screw (10-32 X 49/64)
①70	37608A	1	Flange-Mounting (Includes 72-83, 306, 309A, 311A)	①239	34338	1	Gasket-Air Cleaner
①72	37614	1	Plug-Drain, Oil	①241	36919	1	Collar-Air Cleaner
①75	27897	1	Seal-Oil	①245	36905	1	Filter-Air Cleaner
①80	30574A	1	Shaft-Governor	①250	37122	1	Cover-Air Cleaner
①81	30590A	1	Washer	①260	37696A	1	Housing-Blower
①82	30591	1	Governor Gear ASM (Includes 81)	①261	30200	2	Screw (10-24 X 9/16)
①83	30588A	1	Spool-Governor	①262	650831	2	Screw (1/4-20 X 1/2)
①86	650488	6	Screw (1/4-20 X 1-1/4)	①275	37498	1	Muffler
①89	611298	1	Key-Flywheel	①277	650988	2	Screw (1/4-20 X 2-9/32)
①90	611299	1	Flywheel	①285	35000A	1	Cup-Starter
①92	650815	1	Washer-Belleville	①287	650926	2	Screw (8-32 X 21/64)
①93	650816	1	Nut-Flywheel	①290	37962	1	Line-Fuel, Low Permeation (8.62)
①100	34443C	1	Ignition-Solid State	①292	26460	2	Clamp-Line, Fuel
①101	610118	1	Cover-Spark Plug	①298	28763	2	Screw (10-32 X 35/64)
①103	651007	2	Screw (T-15, 10-24 X 15/16)	①300	37947	1	Fuel Tank ASM
①104	37480	1	Bushing-Cam	①301	37844	1	Cap-Fuel (Black) (1-1/2 Id)
①110	37047	1	Wire-Ground (10.50 With Male And Female Flag Terminals)	①305	35647A	1	Tube-Fill, Oil
①110A	611227	1	Wire-Ground	①306	37610	1	O-Ring
①119	37796	1	Gasket-Head, Cylinder	①307	35499	1	O-Ring
①120	3771	1	Head-Cylinder	①309	650562	1	Screw (10-32 X 1/2)
①125	36780	1	Valve-Exhaust (1/32In Os) (Includes 151)	①309A	650783	1	Screw (10-24 X 3/4)
①125	37288	1	Valve-Exhaust (STD) (Includes 151)	①310	35648	1	Dipstick
①126	37289	1	Valve-Intake (STD) (Includes 151, 151A)	①311A	37611	1	Bracket-Holddown
				①313	34080	1	Spacer
				①324	33177	1	Terminal
				①347	650898A	4	Screw (10-32 X 27/32)
				①370A	36261	2	Decal-Lubrication

Engine Assembly No. 2

Tecumseh LV195EA-362044D

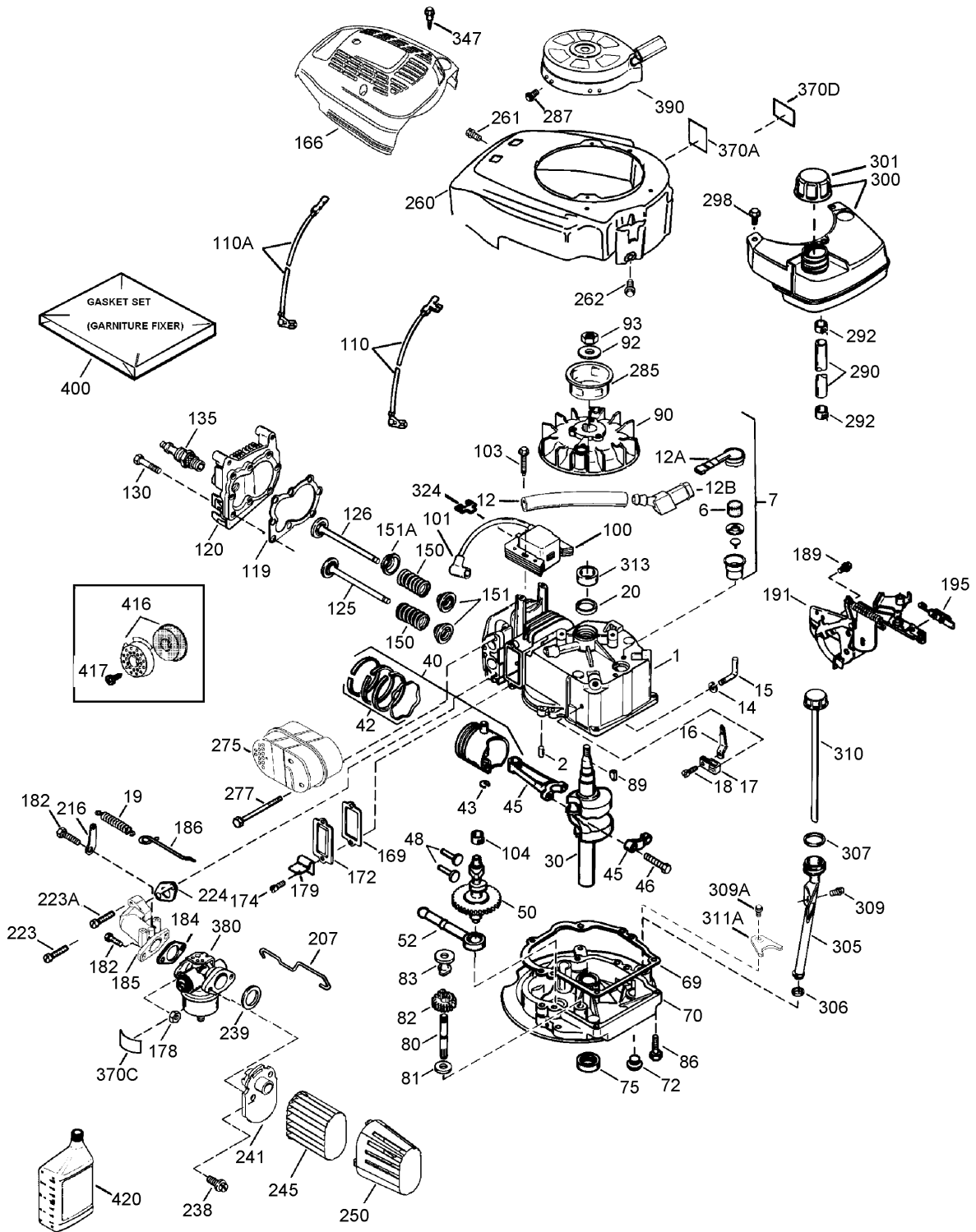

Engine Assembly No. 2 Tecumseh LV195EA-362044D

Ref	Part No.	Qty.	Description				
③370C	37695	1	Decal-Primer				
③370D	35977	1	Decal-Warning				
③380	640350	1	Carburetor ASM (Includes 184)				
③390	590739	1	Starter-Rewind (Note: This Engine Could Have Been Built With Starter 590702)				
③400	37613A	1	Gasket Set (Includes 69, 119, 169, 184, 224, 239, 306)				
③416	37530	1	Spark Arrestor Kit				
③420	730225A	1	Oil-Engine, Sae 30 (4-Cycle)				

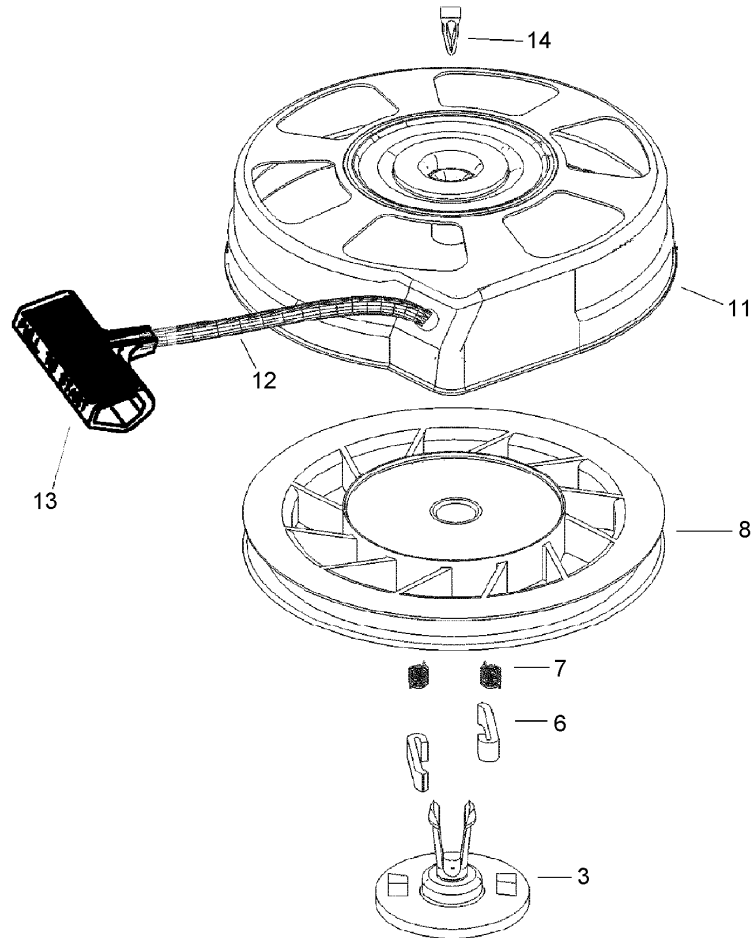

Recoil Starter Assembly No. 590739 Tecumseh LV195EA-362044D

Ref	Part No.	Qty.	Description
③3	590740	1	Retainer
③6	590616	2	Dog-Starter
③7	590617	2	Spring-Dog
③8	590618A	1	Pulley And Rewind Spring ASM
③11	590638A	1	Starter Housing ASM (40 Degree Grommet)
③12	590535	1	98 Starter Rope (Cut To Length)
③13	590701	1	Handle-Starter
③14	590760	1	Clip-Spring

--	--	--	--

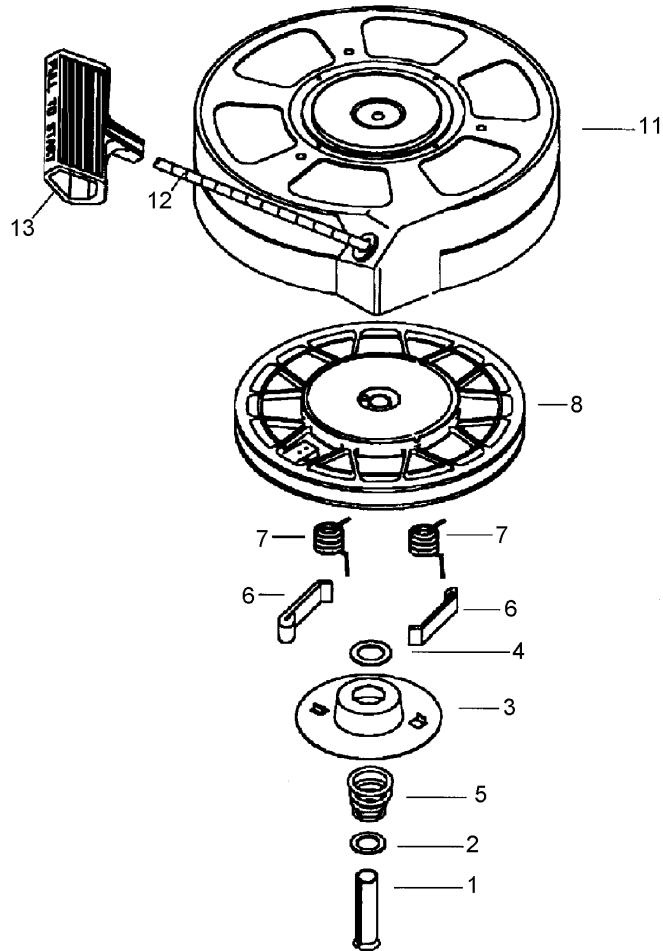

Recoil Starter Assembly No. 590702 (optional) Tecumseh LV195EA-362044D

Ref	Part No.	Qty.	Description				
❶	590599A	1	Spring Pin ASM (Includes 4)				
❷	590600	1	Washer				
❸	590696	1	Retainer				
❹	590601	1	Washer				
❺	590697	1	Spring-Brake				
❻	590698	2	Dog-Starter				
❼	590699	2	Spring-Dog				
❽	590700	1	Pulley And Rewind Spring ASM				
❾	590703A	1	Starter Housing ASM (40 Degree Grommet)				
❿	590535	1	98 Starter Rope (Cut To Length)				
⓫	590701	1	Handle-Starter				

Attachments and Accessories

For 10685 - Insight Lawn Mower

Product Name	Model/Part
Lawn Boy Paint	110-8800
Height-Of-Cut Kit	110-8801
Loose Parts Kit	112-1526
Replacement Bag	89815
Rear Bag Kit	89913
21 Inch Blade	89914
Cruise Control Kit	89919
Air Filter	89945
Spark Plug	89946
Cup Holder	89951

NOTES

