



Insight™ Gold Lawn Mower

Model No. 10695 - 250000001 and up.

Parts Catalog

Ordering Replacement Parts

To order replacement parts, please supply the part number, the quantity, and the description of each part desired.

Understanding Reference Numbers

Each identified part in an illustration has a reference number. The reference number for a part also appears in the parts list, along with other information about the part.

This catalog uses two special reference number formats, one to indicate parts in a service assembly and another to indicate the quantity of a given part in an illustration.

Service Assembly Reference Numbers

Parts in service assemblies have reference numbers in the form a:b. The a represents the reference number of the entire service assembly and the b represents a sequential number unique to each part within the service assembly.

For example, a wheel assembly might be identified by reference number 6, the tire by 6:1, the valve by 6:2, and the wheel by 6:3. When you order the assembly identified by reference number 6, you receive all parts identified by reference numbers 6:1, 6:2, and 6:3. However, you may also order any part individually. Reference numbers of this type appear in illustrations and in part lists.

Reference Numbers Indicating Quantity

In an illustration, if a reference number indicates more than one part, the reference number has the form nX y. The n represents the quantity of the part, the X is the multiplication symbol, and the y represents the reference number.

For example, in an illustration, the reference number 2X 37 means that two of the parts identified by reference number 37 are indicated.

Contents

Description	Page	Description	Page
Front End and Tunnel Assembly 3	Piston and Connecting Rod Assembly Honda GCV160A STL1 16
Housing Assembly No. 108-9346 4	Camshaft Pulley Assembly Honda GCV160A STL1 17
Side Discharge Assembly 5	Recoil Starter Assembly Honda GCV160A STL1 18
Rear Axle and Transmission Assembly 6	Fan Cover Assembly Honda GCV160A STL1 19
Transmission Assembly No. 107-3860 7	Carburetor Assembly Honda GCV160A STL1 20
Upper Handle Assembly 8	Air Cleaner Assembly Honda GCV160A STL1 21
Lower Handle Assembly 9	Muffler Assembly Honda GCV160A STL1 22
Blade and Engine Assembly 10	Flywheel Assembly Honda GCV160A STL1 23
Clip Assembly 11	Control Assembly Honda GCV160A STL1 24
Rear Bag Assembly 12	Choke Base Assembly Honda GCV160A STL1 25
Cylinder Barrel Assembly Honda GCV160A STL1 13	Top Cover Assembly Honda GCV160A STL1 26
Oil Pan Assembly Honda GCV160A STL1 14	Label Assembly Honda GCV160A STL1 27
Crankshaft Assembly Honda GCV160A STL1 15	Attachments and Accessories List 28

Part Description Abbreviations

Part descriptions in this catalog may include the following abbreviations.

AR. as required	HWHTF. hex washer head thread forming
ASM. assembly	HYD. hydraulic
BBC. blade brake clutch	INC. incorporated
CARR. carriage	LH. left hand
DEG. degrees	NI. nylon insert
EXT. external	NPTF. national pipe thread fine
FH. flat head	PPH. phillips pan head
GA. gauge	PPHTF. phillips pan head thread forming
HF. hex flange	PRH. phillips round head
HH. hex head	PTH. phillips truss head
HHF. hex head flange	PTO. power take off
HHFTF. hex head flange thread forming	RH. right hand
HJ. hex jam	ROPS. roll over protection system
HLH. hex lag head	SFH. slotted fillister head
HOC. height-of-cut	SHH. slotted hex head
HSBH. hex socket button head	SHWH. slotted hex washer head
HSFH. hex socket flat head	SPH. slotted pan head
HSH. hex socket head	SQH. square head
HWH. hex washer head	

Footnotes

- ❶ Not illustrated
- ❷ Obtain from your local Honda dealer

- ❸ Not serviced separately

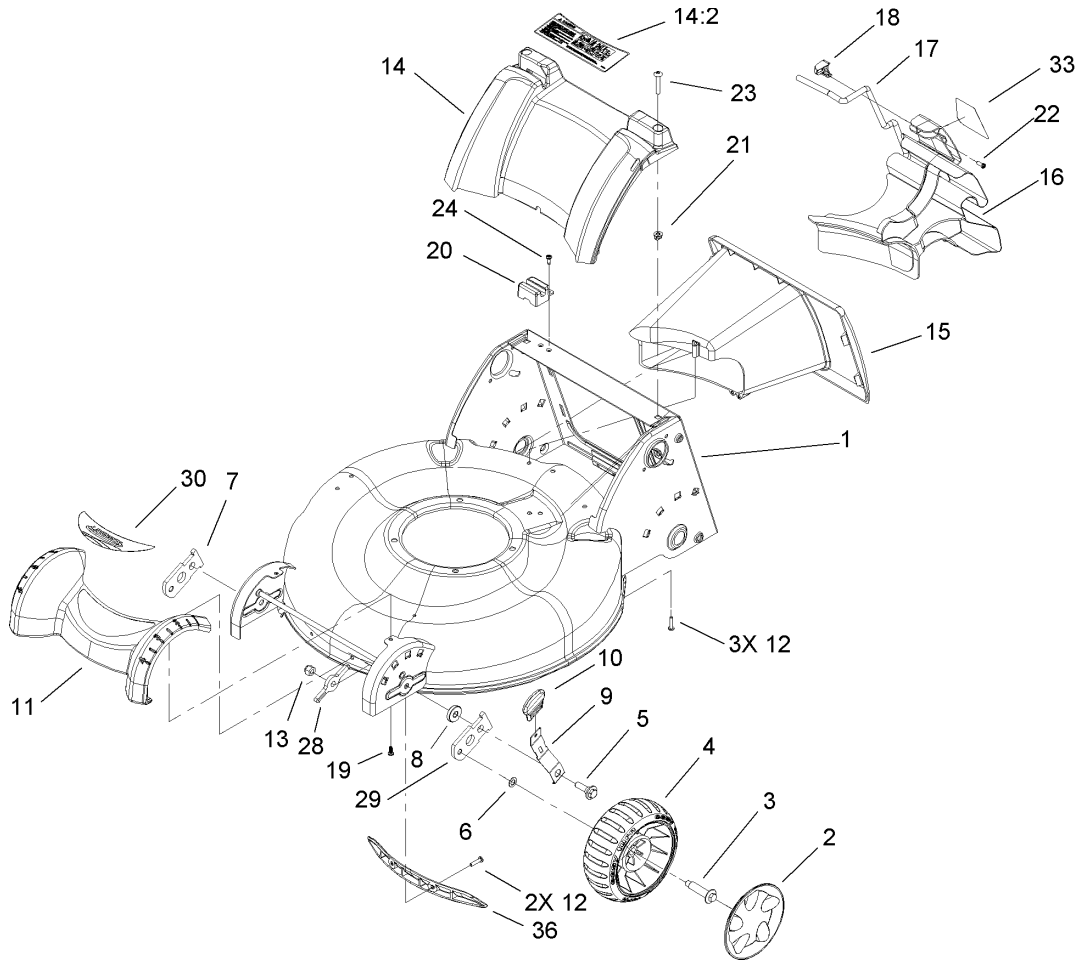

Front End and Tunnel Assembly

Ref	Part No.	Qty.	Description
1	108-9346	1	Housing ASM
2	107-3886	2	Cover-Wheel, 7In
3	614650	2	Bolt-Shoulder
4	107-3891	2	7In Wheel ASM
5	614672	2	Bolt-Shoulder
6	40-1940	2	Washer
7	107-3877	1	Arm-Pivot, RH
8	92-4890	2	Washer
9	107-3878	2	Arm-Spring
10	107-1904	2	Knob-Lever, HOC
11	107-3926	1	Cover-Front
12	108-7476	5	Screw-Plastite
13	3296-39	2	Nut-Lock, NI
14	108-9348	1	Cover-Rear
14:2	107-3888	1	Decal-Safety
15	107-3905	1	Tunnel
16	107-3907	1	Plug-Chute
17	108-1038	1	Latch-Plug
18	108-0956	1	Retainer-Latch
19	108-7475	2	Screw-Plastite
20	108-0966	1	Module-Switch
21	94-1610	2	Nut-Clip
22	32144-111	1	Screw-PPH
23	108-0965	2	Screw-PTH

Ref	Part No.	Qty.	Description
24	105-6849	2	Screw-Thread Forming
28	108-1048	2	Washer-Support, Front
29	108-1044	1	Arm-Pivot, LH
30	108-7453	1	Decal
33	108-7461	1	Decal
36	108-7502	1	Insert-Housing
39	110-1751	1	Mulch Plug ASM

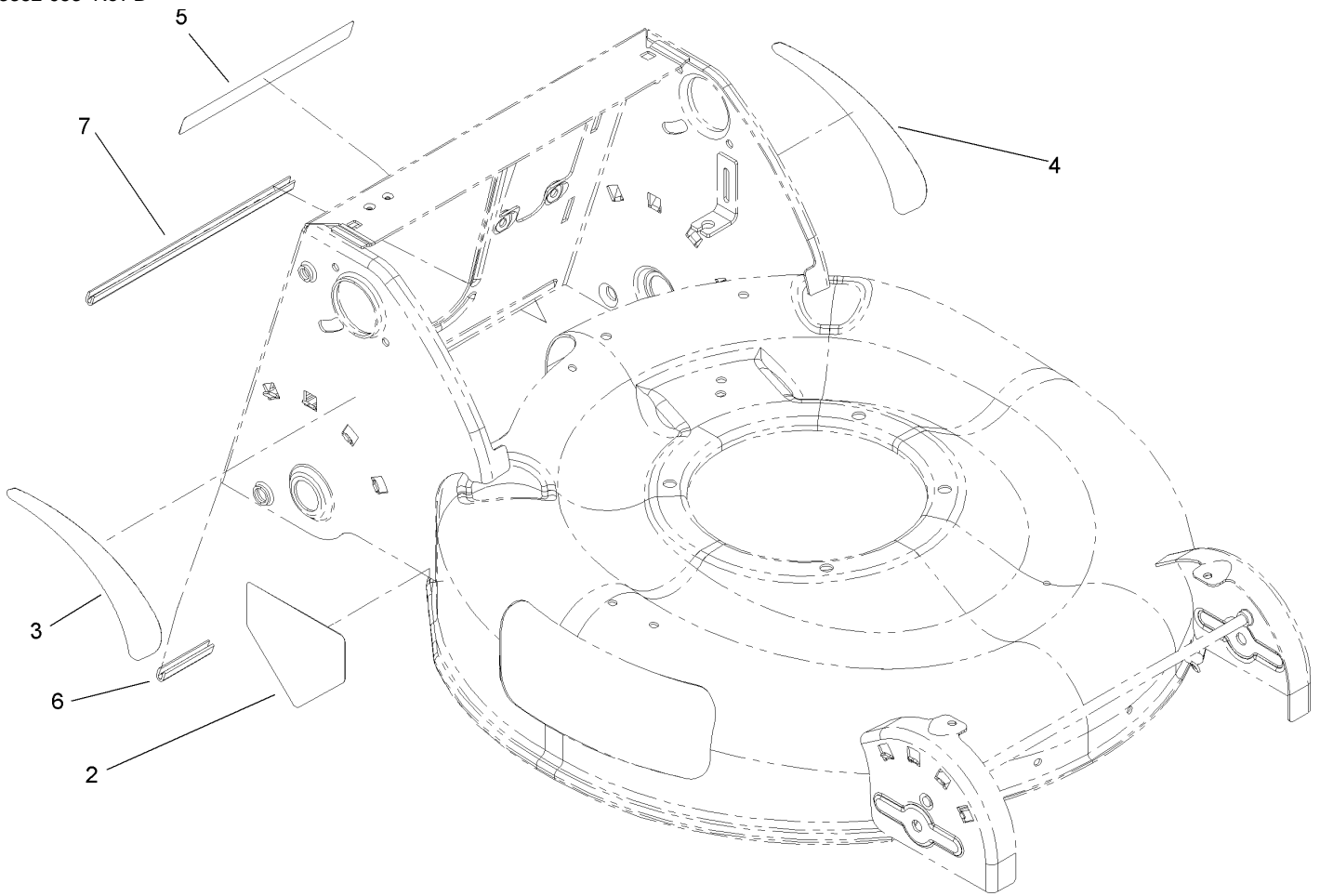

Housing Assembly No. 108-9346

Ref	Part No.	Qty.	Description				
2	94-8072	1	Decal-Danger				
3	108-7450	1	Decal-HOC, RH				
4	108-7451	1	Decal-HOC, LH				
5	107-3889	1	Decal-Safety				
6	108-7504	1	Strip-Edge				
7	108-9380	1	Strip-Edge				

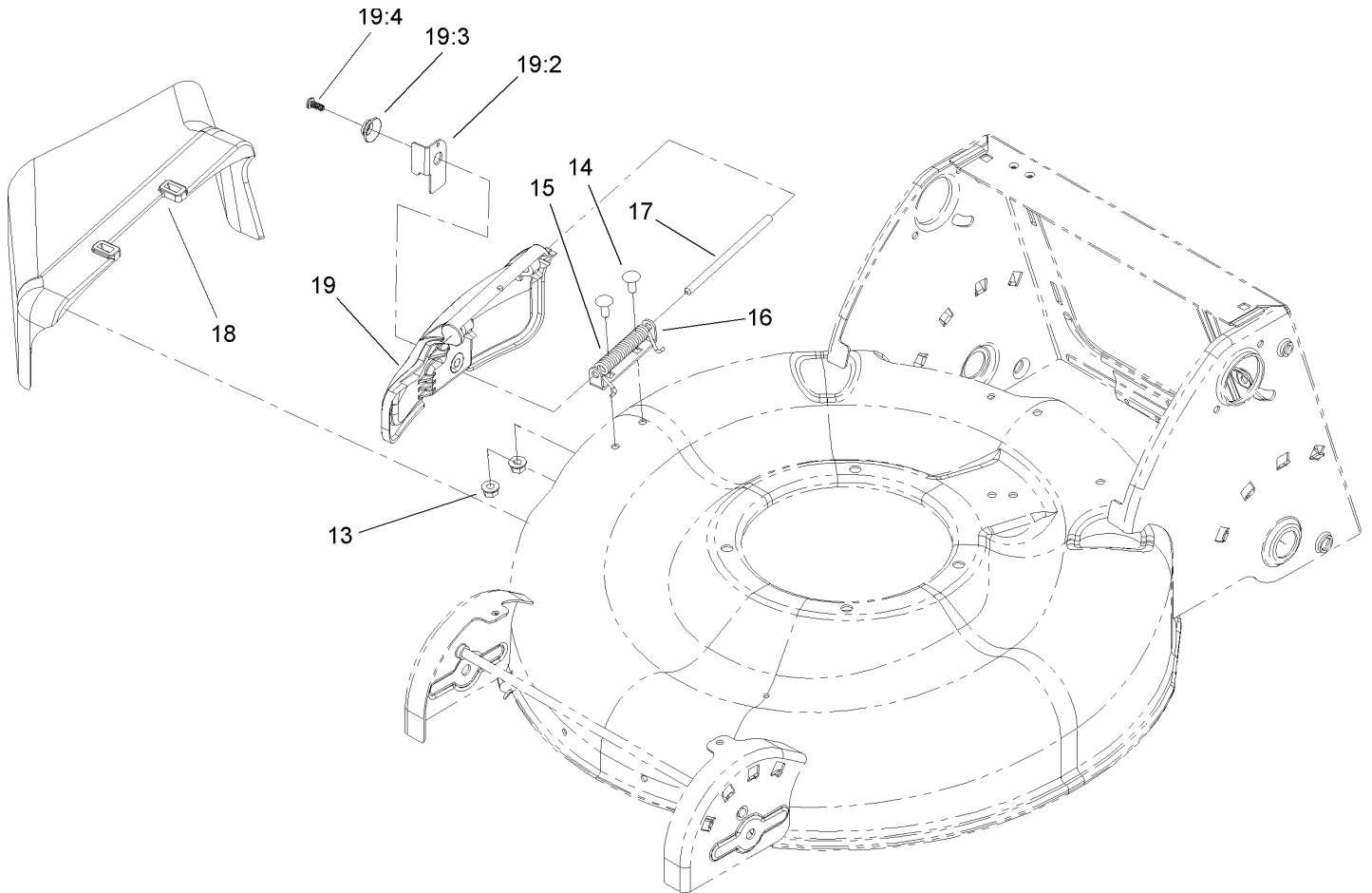

Side Discharge Assembly

Ref	Part No.	Qty.	Description
13	32128-32	2	Nut-HHF
14	3229-11	2	Screw-CARR
15	99-5293	1	Spring-Torsion
16	99-5292	1	Bracket-Cover
17	99-5291	1	Rod-Cover
18	105-3028	1	Chute-Discharge, Side
19	106-8376	1	Discharge Door ASM
19:2	107-0795	1	Latch-Door
19:3	107-7456	1	Cap-Door
19:4	107-7461	1	Screw-Plastite

--	--	--	--

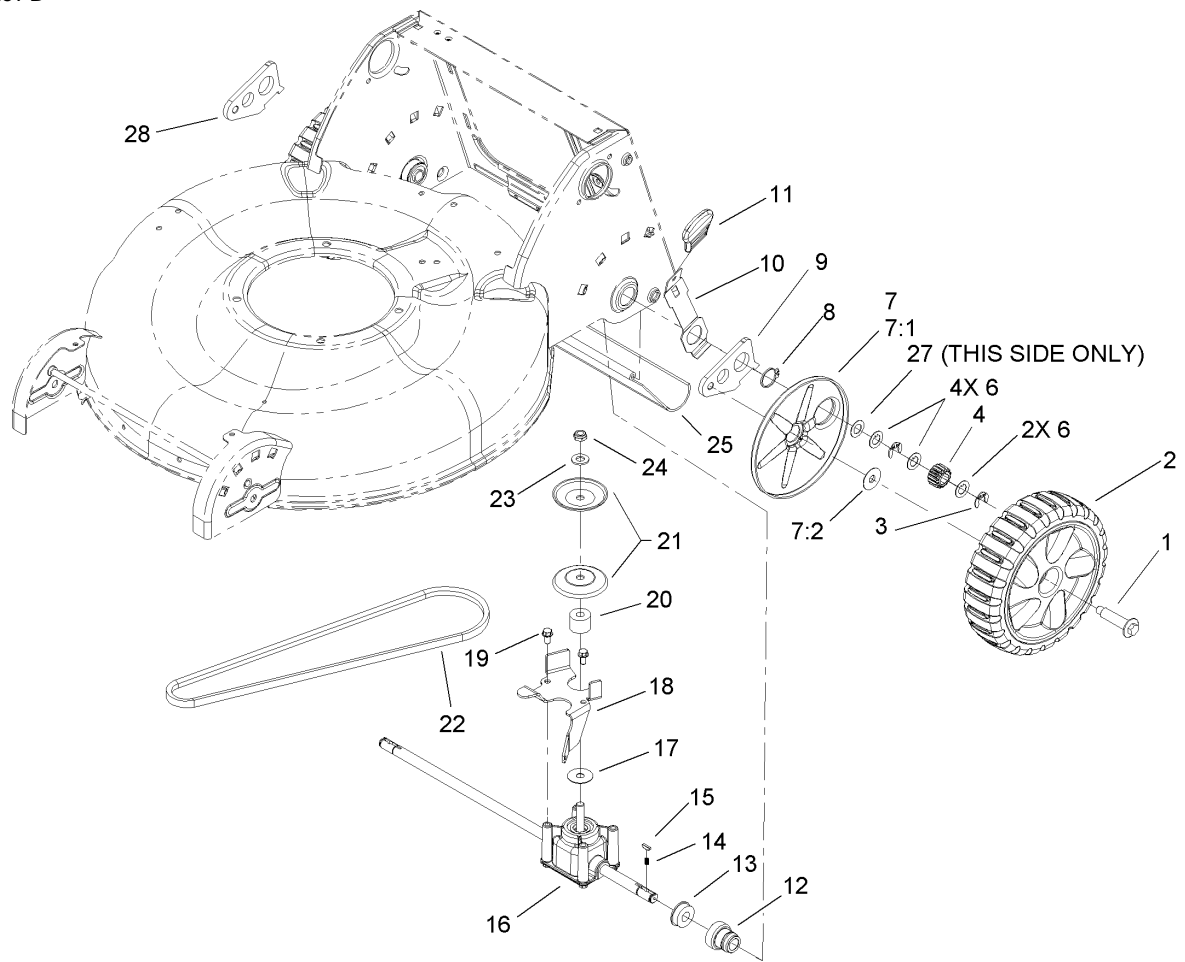

Rear Axle and Transmission Assembly

Ref	Part No.	Qty.	Description
1	614650	2	Bolt-Shoulder
2	107-3906	2	Rear Wheel ASM
3	65-2720	4	Klipring-Locking
4	105-3040	2	Gear-Pinion, 15T
6	105-6840	6	Washer-Thrust
7		2	Wheel Cover ASM
7:1	107-1919	1	Cover-Wheel
7:2	614426	1	Washer-Stepped
8	32151-36	2	Ring-Retaining
9	108-9344	1	Arm-Rear Pivot, LH
10	107-3880	2	Arm-Spring, Rear
11	107-1904	2	Knob-Lever, HOC
12	104-8698	2	Retainer-Bearing, HOC
13	104-8699	2	Bearing-Ball
14	39-9650	2	Spring-Compression
15	612066	2	Key
16	107-3860	1	Transmission ASM
17	105-6814	1	Washer-Shield
18	107-3884-03	1	Bracket-Transmission
19	32144-4	2	Screw-HWH
20	92-5791	1	Spacer
21	100-1176	2	Pulley-Half
22	91-2258	1	V-Belt
23	3256-24	1	Washer-Flat

Ref	Part No.	Qty.	Description
24	3296-5	1	Nut-Lock
25	107-3904	1	Shield-Trailing
27	36-4780	1	Washer
28	108-9343	1	Arm-Rear Pivot, RH

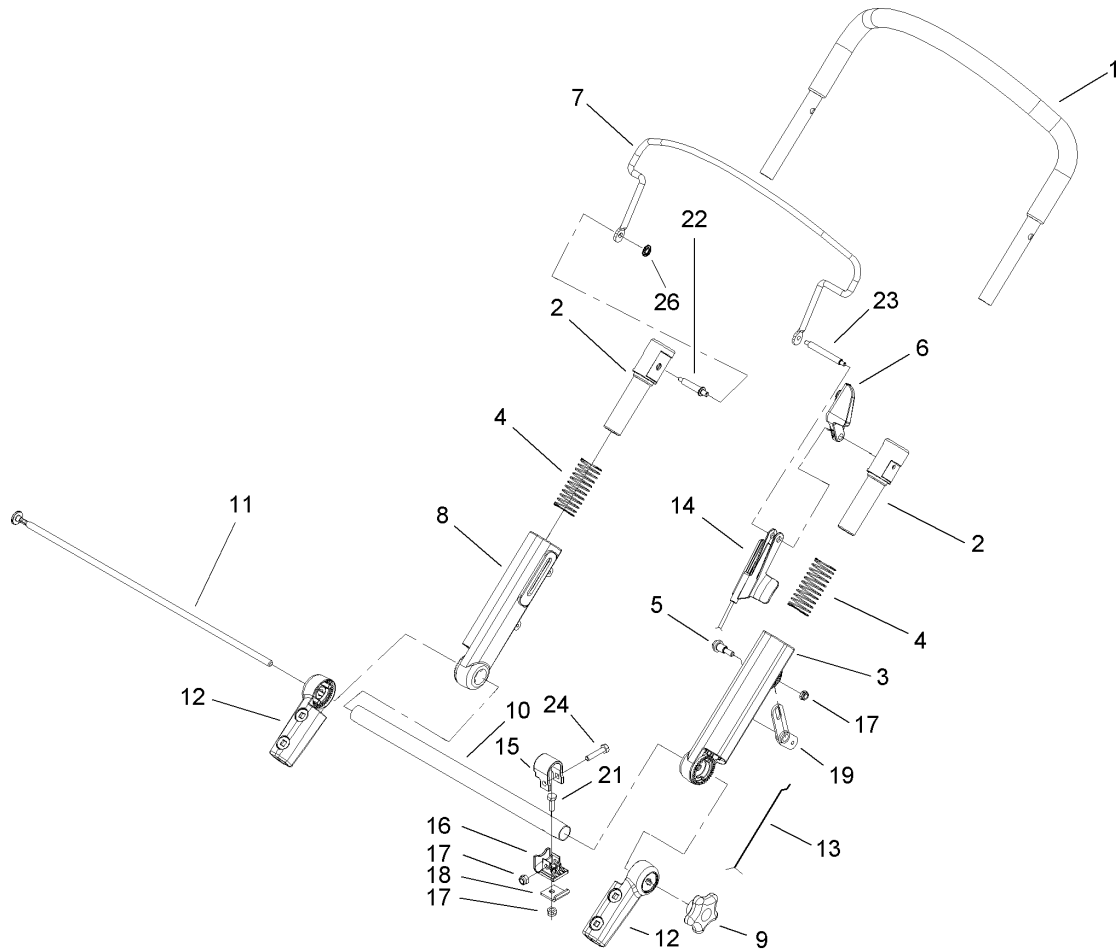

Upper Handle Assembly

Ref	Part No.	Qty.	Description
1	108-0974	1	Upper Handle ASM
2	107-3866	2	Sleeve-Handle
3	107-3864	1	Slide-Top, LH
4	107-3869	2	Spring-Compression
5	104-0858	1	Bolt-Shoulder
6	107-3943	1	Stop-Bail
7	107-3874-03	1	Bail-Brake
8	107-3863	1	Slide-Top, RH
9	107-3937	1	Knob
10	107-3867-03	1	Tube-Cross
11	107-3871	1	Rod-Threaded
12	107-3865	2	Mount-Handle, Lower
13	107-3902	1	Cable-Traction
14	107-3903	1	Cable-Brake
15	108-1045	1	Support-Cable
16	108-1046	1	Support-Guide, Cable
17	3296-73	2	Nut-Lock, NI
18	108-7454	1	Clamp-Cable
19	107-3893	1	Lever-Traction
21	321-4	1	Screw-HH
22	108-0959	1	Pin-Handle
23	108-1008	1	Pin-Bail, LH
24	108-0988	1	Screw-CARR
26	108-9378	1	Retainer-Push On

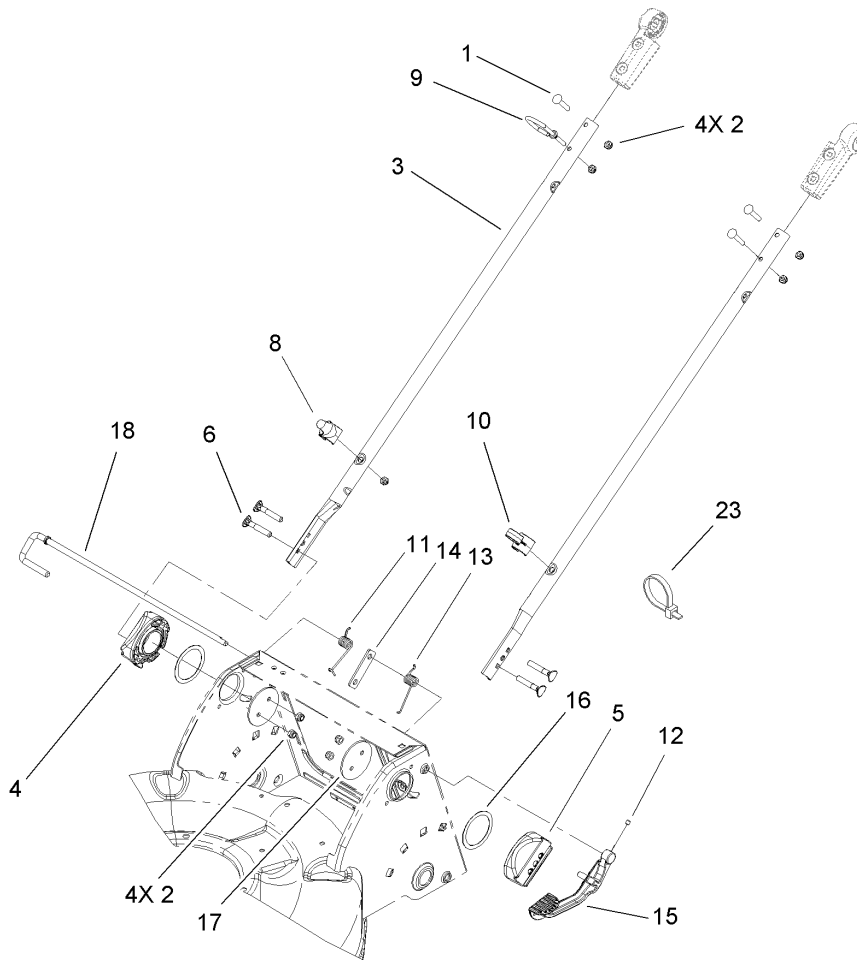

Lower Handle Assembly

Ref	Part No.	Qty.	Description
1	108-0988	3	Screw-CARR
2	3296-73	9	Nut-Lock, NI
3	107-3887-03	2	Tube-Lower
4	108-9339-03	1	Mount-Handle, RH
5	108-9340-03	1	Mount-Handle, LH
6	95-4453	4	Screw
8	108-0994	1	Guide-Rope, Lower
9	107-3908	1	Guide-Rope, Upper
10	106-6805	1	Guide-Cable
11	108-0952	1	Spring-Torsion, LH
12	108-0989	1	Screw-Set
13	108-0953	1	Spring-Torsion, RH
14	107-3946	1	Plate-Lock, Handle
15	108-0985-03	1	Lever-Release
16	107-3947	2	Washer-Nylon
17	107-3944-03	2	Plate
18	107-3892	1	Rod-Release
23	614249	1	Strap-Tie

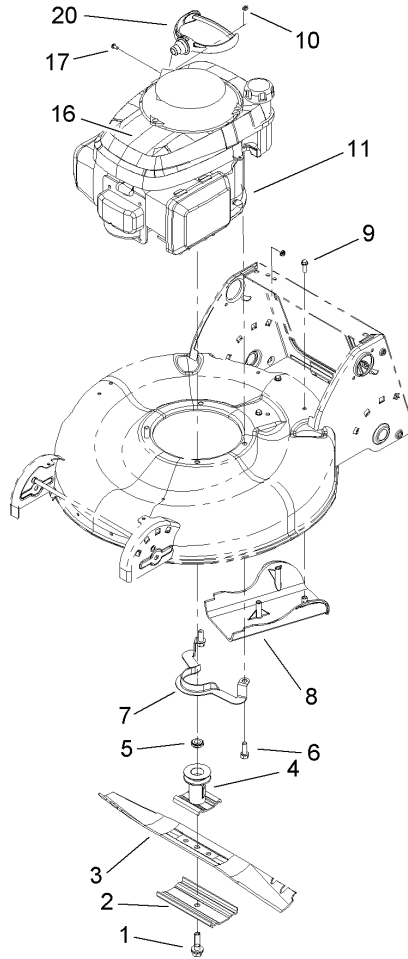

Blade and Engine Assembly

Ref	Part No.	Qty.	Description				
1	105-8579	1	Bolt-Blade				
2	108-3766-03	1	Support-Blade				
3	108-0954-03	1	Blade-21 In				
4	106-3987	1	Blade Driver ASM				
5	106-3999	1	Spacer-Driver				
6	92-1624	3	Screw				
7	105-3030-03	1	Guide-Belt				
8	107-3909	1	Cover-Belt				
9	46-8091	3	Screw-HWH				
10	92-1701	1	Stop-Rope				
11		1	Engine-Honda, Gcv160A Stl1				
16	108-7529	1	Decal				
17	47-2830	1	Screw-Metric				
20	106-8345	1	Handle-Recoil				

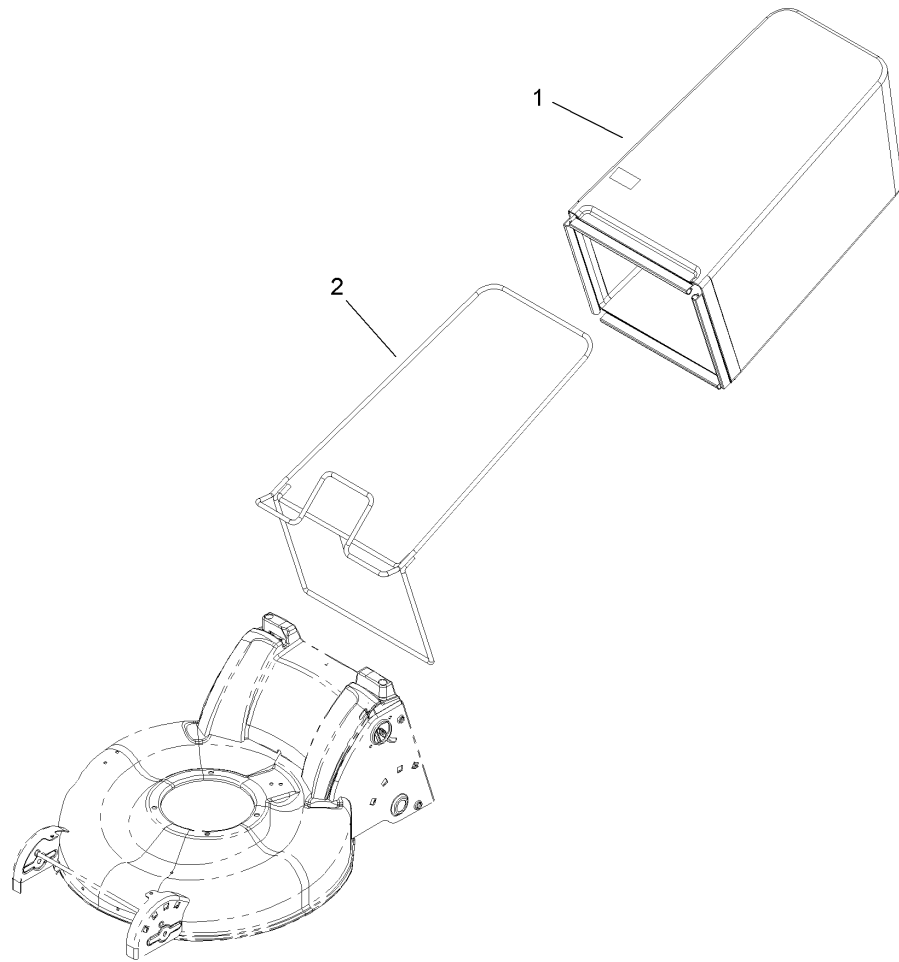

Rear Bag Assembly

Ref	Part No.	Qty.	Description
1	107-3911	1	Bag-Grass
2	107-3912-03	1	Bag Frame ASM

--	--	--	--

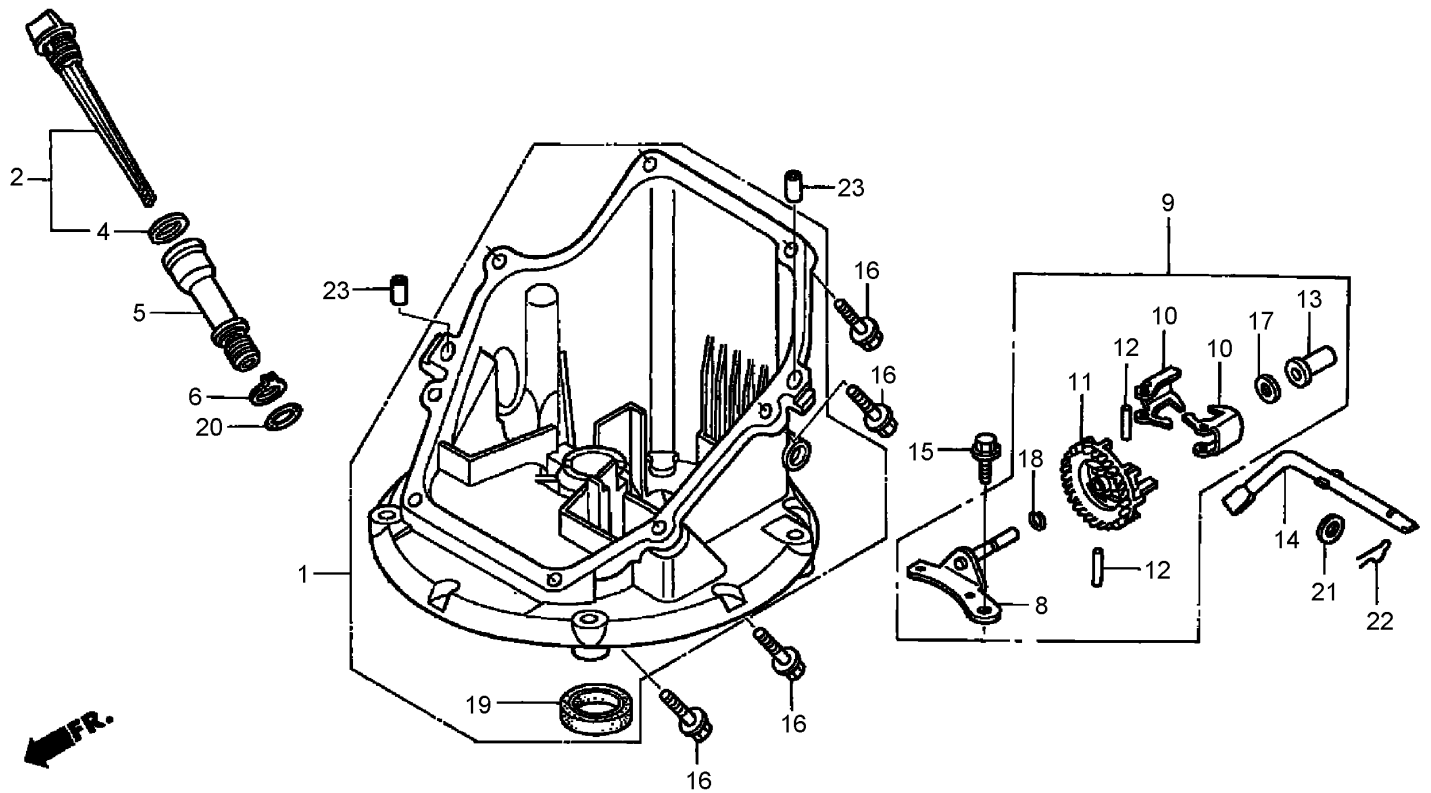

Oil Pan Assembly Honda GCV160A STL1

Ref	Part No.	Qty.	Description
❶	11300-ZM0-405	1	Oil Pan ASM (000)
❷	15650-ZM0-801	1	Dipstick-Oil
❸	15625-ZE6-000	1	Gasket-Cap, Oil Filler
❹	15631-ZM0-000	1	Extension-Filler, Oil
❺	15639-ZM0-000	1	Washer-Lock, Extension
❻	16508-ZM0-010	1	Shaft-Holder, Governor
❼	16510-ZM0-010	1	Governor ASM
❽	16511-ZL8-000	2	Weight-Governor
❾	16512-ZM0-000	1	Holder-Weight, Governor
❿	16513-ZE1-000	2	Pin-Weight, Governor
⓫	16531-ZE1-000	1	Slider-Governor
⓬	16541-ZM0-000	1	Shaft-Arm, Governor
⓭	90014-952-000	1	Bolt-Flange (6X14)

Ref	Part No.	Qty.	Description
❶❹	90121-952-000	8	Bolt-Flange (6X25)
❶❷	90451-ZE1-000	1	Washer-Thrust (6Mm)
❶❸	90602-ZE1-000	1	Clip-Holder, Governor
❶❹	91202-ZL8-003	1	Seal-Oil (28X41.25X6)
❶❺	91303-KF0-003	1	O-Ring (14.8X2.4) (Arai)
❶❻	91356-MA6-005	1	O-Ring
❶❼	94101-06800	1	Washer-Plain (6Mm)
❶❽	94251-08000	1	Pin-Lock (8Mm)
❶❾	94301-08200	2	Pin-Dowel (8X20)

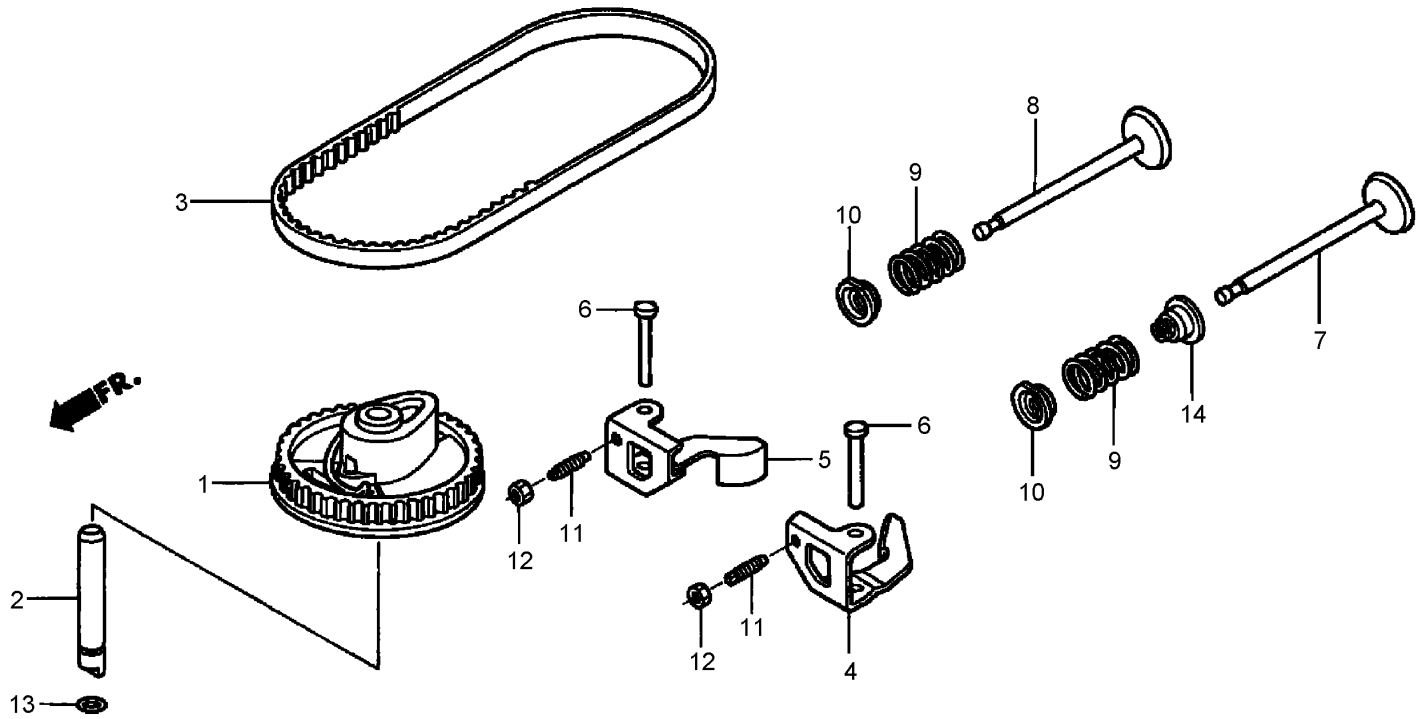

Camshaft Pulley Assembly Honda GCV160A STL1

Ref	Part No.	Qty.	Description
❶	14320-ZL8-010	1	Pulley-Camshaft
❷	14324-ZL8-000	1	Shaft-Pulley
❸	14400-Z0J-014	1	Belt-Timing (84Hu7 G-200)
❹	14431-Z0J-000	1	Rocker Arm-Valve, Intake
❺	14441-Z0J-000	1	Rocker Arm-Valve, Exhaust
❻	14461-ZL8-000	2	Shaft-Arm, Rocker
❼	14711-Z0J-000	1	Valve-Intake
❽	14721-ZL8-000	1	Valve-Exhaust
❾	14751-ZL8-000	2	Spring-Valve
❿	14771-Z0J-000	2	Retainer-Spring, Valve
⓫	90012-333-000	2	Screw-Tappet, Adj.
⓬	90206-001-000	2	Nut-Tappet, Adj.
⓭	91301-ZM0-V31	1	O-Ring (6.8X1.9)

Ref	Part No.	Qty.	Description
⓮	12209-ZM0-003	1	Seal-Stem, Valve

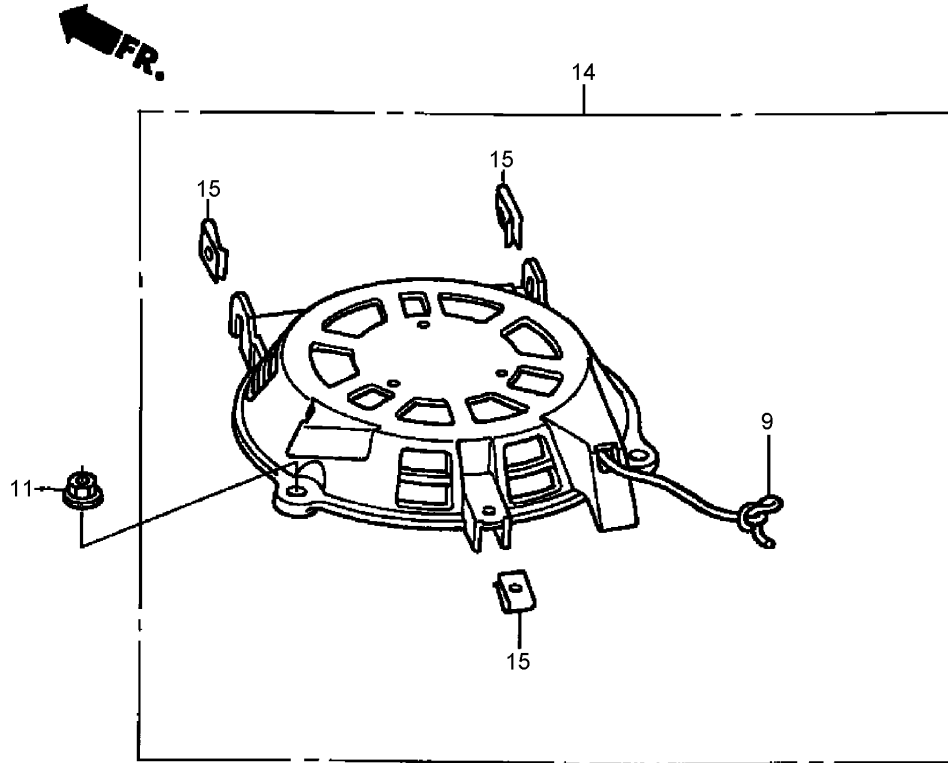

Recoil Starter Assembly Honda GCV160A STL1

Ref	Part No.	Qty.	Description				
9	28462-Z0L-V71	1	Rope-Starter, Recoil				
11	90201-ZM0-000	3	Nut-Flange (6Mm)				
14	28400-Z0L-V72	1	Recoil Starter ASM				
15	66871-KY2-700	3	Nut-Cowl				

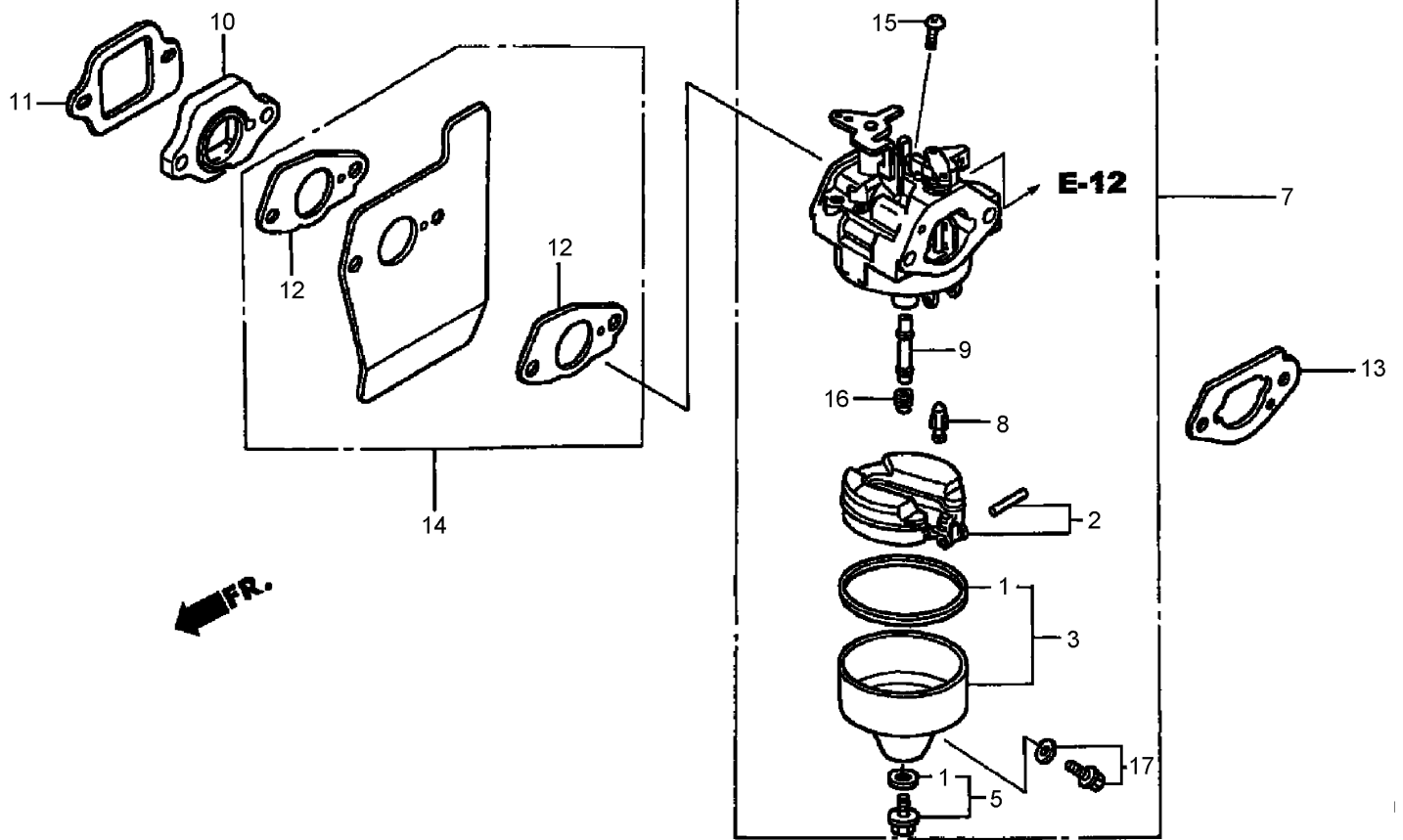

Carburetor Assembly Honda GCV160A STL1

Ref	Part No.	Qty.	Description
●1	16010-883-015	1	Gasket Set
●2	16013-ZL1-003	1	Float Set
●3	16015-887-782	1	Chamber Set-Float
●5	16028-ZE0-005	1	Screw-Set
●7	16100-Z0L-802	1	Carburetor ASM (Bb62G B)
●8	16155-ZM0-013	1	Valve-Float (Carburetor No.)
●9	16166-ZM0-003	1	Nozzle-Main
●10	16211-ZL8-000	1	Insulator-Carburetor
●11	16212-ZL8-000	1	Gasket-Insulator
●12	16221-883-800	2	Gasket-Carburetor
●13	16228-ZL8-000	1	Gasket-Carburetor (Choke Side)
●14	19650-ZM0-000	1	Guide-Air
●15	93500-05006-0H	1	Screw-Pan (5X6)

Ref	Part No.	Qty.	Description
●16	99101-124-0600	1	Jet-Main (#60)
●16	99101-124-0620	1	Jet-Main (#62)
●16	99101-124-0650	1	Jet-Main (#65)
●17	16024-ZE1-811	1	Screw Set-Drain

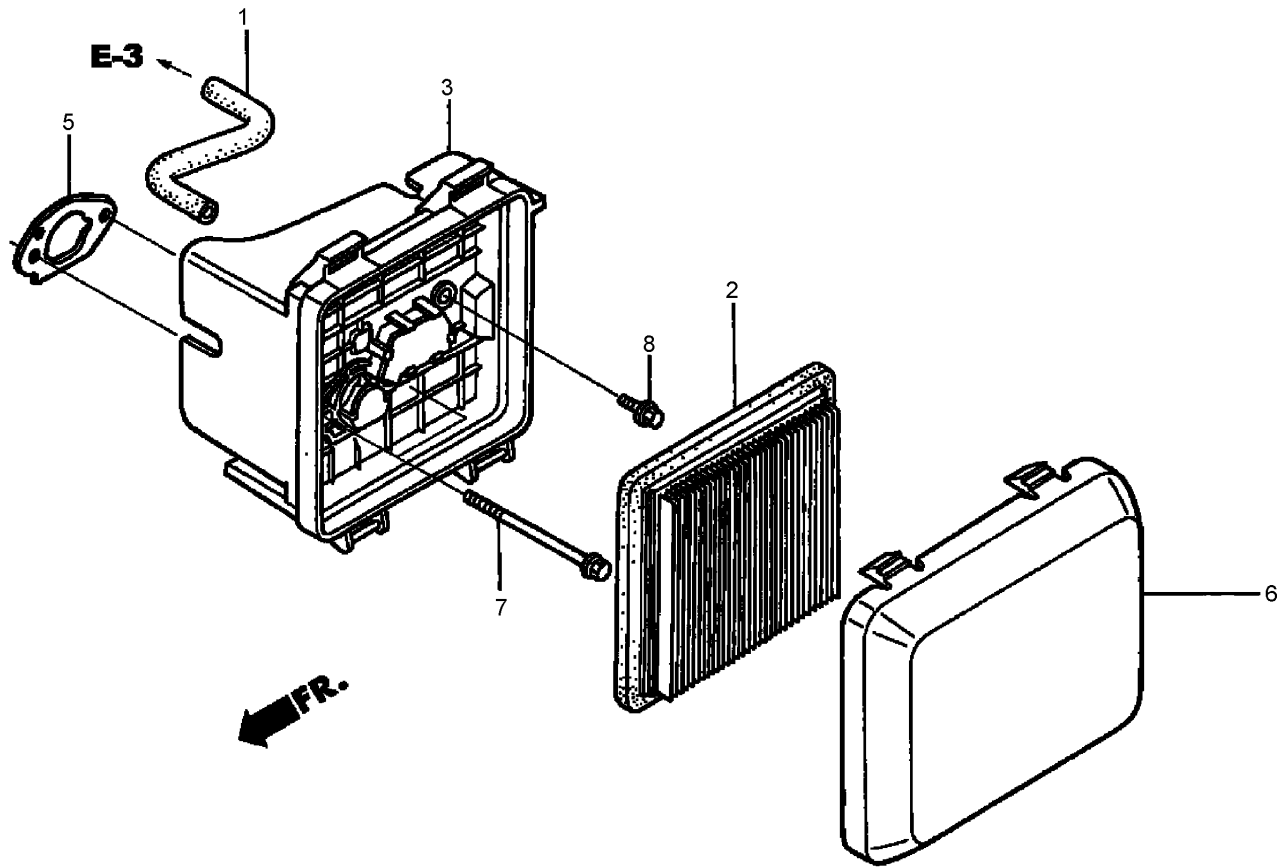

Air Cleaner Assembly Honda GCV160A STL1

Ref	Part No.	Qty.	Description
❶	15721-ZM0-000	1	Tube-Breather
❷	17211-ZL8-013	1	Element-Cleaner, Air
❸	17220-ZM0-000	1	Air Cleaner Case ASM
❺	17228-ZM0-000	1	Gasket-Cleaner, Air
❻	17231-Z0L-030	1	Cover-Cleaner, Air
❼	90003-ZM0-000	2	Bolt-Flange (6X86) (Ct200)
❽	95701-06014-08	1	Bolt-Flange (6X14)

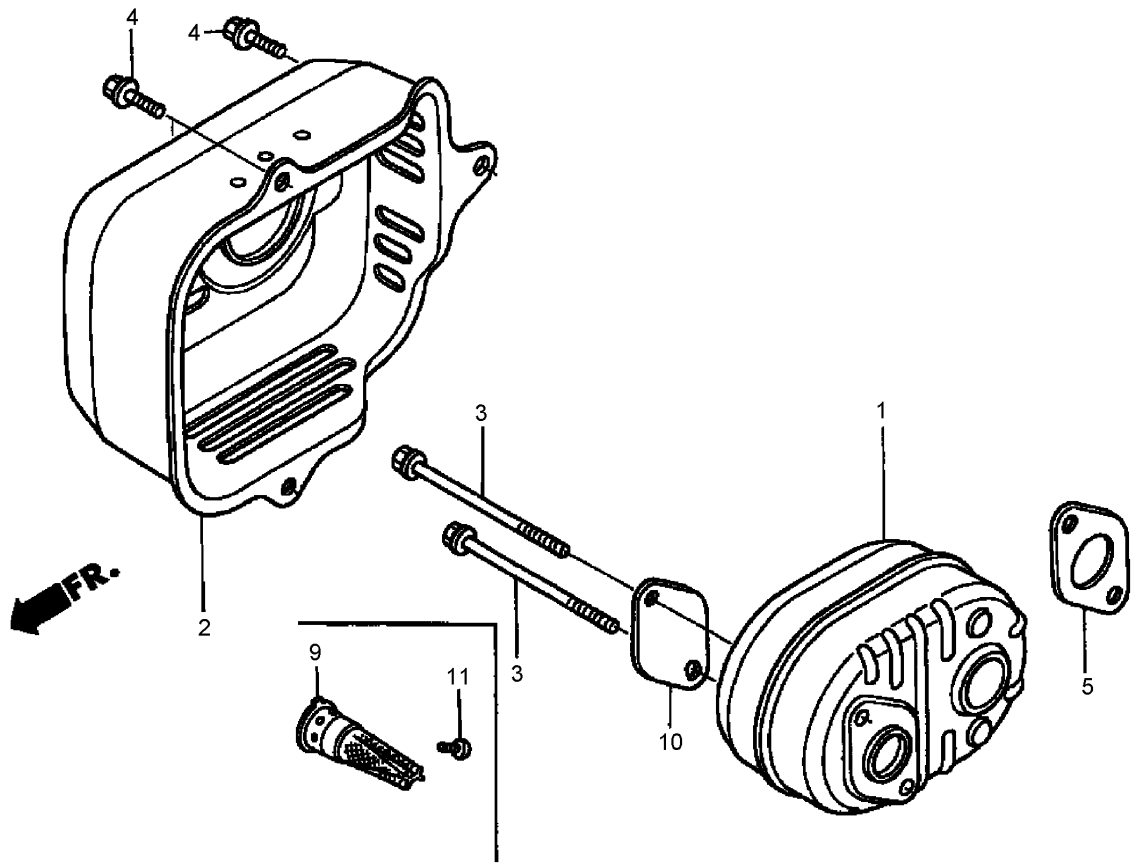

Muffler Assembly Honda GCV160A STL1

Ref	Part No.	Qty.	Description
❶	18310-ZM0-000	1	Muffler
❷	18321-Z0L-J00	1	Protector-Muffler (Cbu)
❸	90004-ZL8-000	2	Bolt-Flange (6X79) (Ct200)
❹	90013-883-000	3	Bolt-Flange (6X12) (Ct200)
❺	18381-ZL8-305	1	Gasket-Muffler
❾	18350-ZL8-000	1	Arrester-Spark
❿	18356-ZL8-000	1	Plate-Number, Arrester
⓫	90055-ZE1-000	1	Screw-Tapping (4X6)

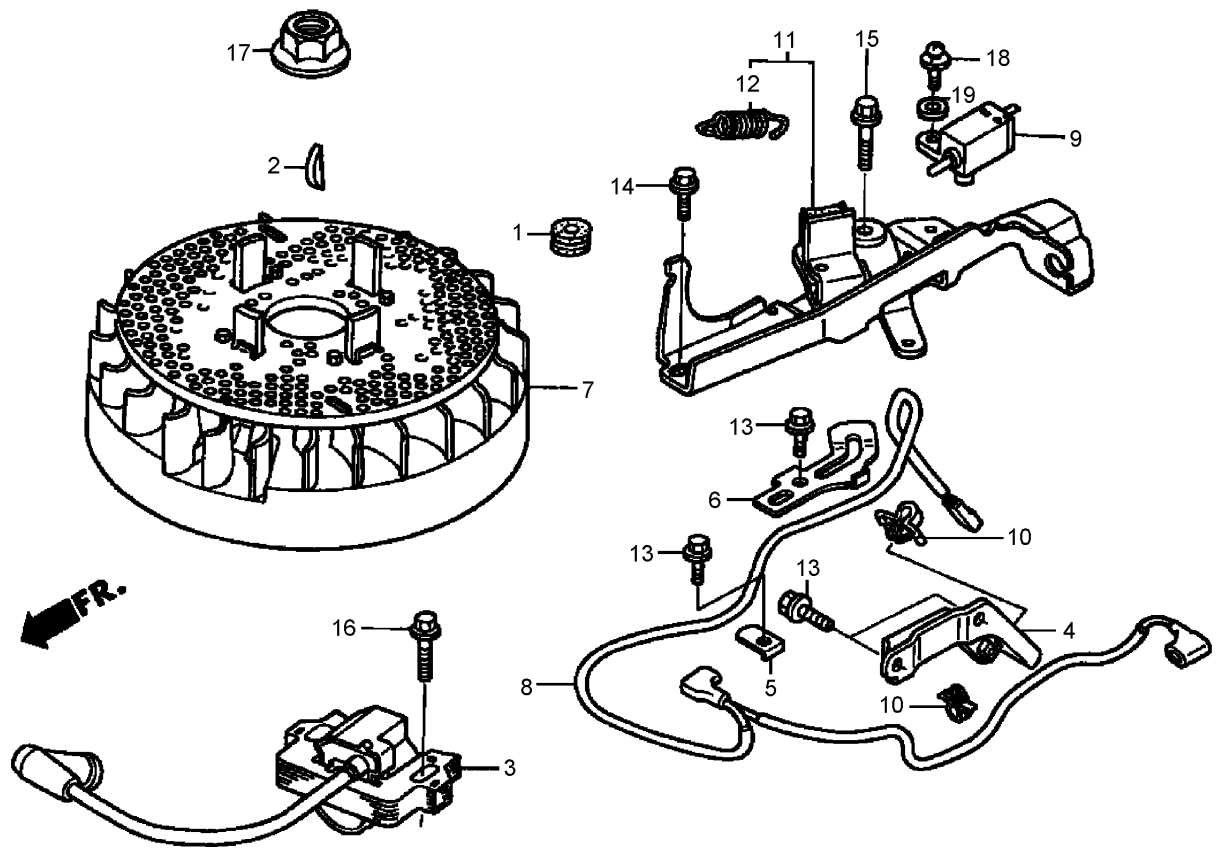

Flywheel Assembly Honda GCV160A STL1

Ref	Part No.	Qty.	Description
❶	11344-MB0-000	1	Grommet-Cover, A-Rr
❷	13331-357-000	1	Key-Woodruff (25X18)
❸	30500-ZL8-004	1	Ignition Coil ASM
❹	30547-Z0L-S00	1	Clamp-Wire, Stop Switch
❺	30548-ZL8-000	1	Clamp-Wire, Stop Switch
❻	30549-ZL8-000	1	Clamp-Wire
❼	31105-ZM0-000	1	Flywheel ASM
❽	32195-Z0L-S00	1	Wire-Switch, Stop
❾	35120-ZM0-003	1	Engine Stop Switch ASM
❿	51125-Z0L-003	2	Holder-Wire
❿	90681-959-003	2	Clip-Cable (A)
⓫	75110-Z0L-800	1	Brake Sub ASM
⓬	75113-ZM0-000	1	Spring-Lever, Brake

Ref	Part No.	Qty.	Description
⓭	90013-883-000	4	Bolt-Flange (6X12) (Ct200)
⓮	90014-952-000	1	Bolt-Flange (6X14)
⓯	90018-ZE1-000	1	Bolt-Flange
⓰	90022-888-010	1	Bolt-Flange (6X20)
⓱	90201-878-003	1	Nut (14Mm)
⓲	93892-04012-00	1	Screw-Washer
⓳	94103-04000	1	Washer-Plain

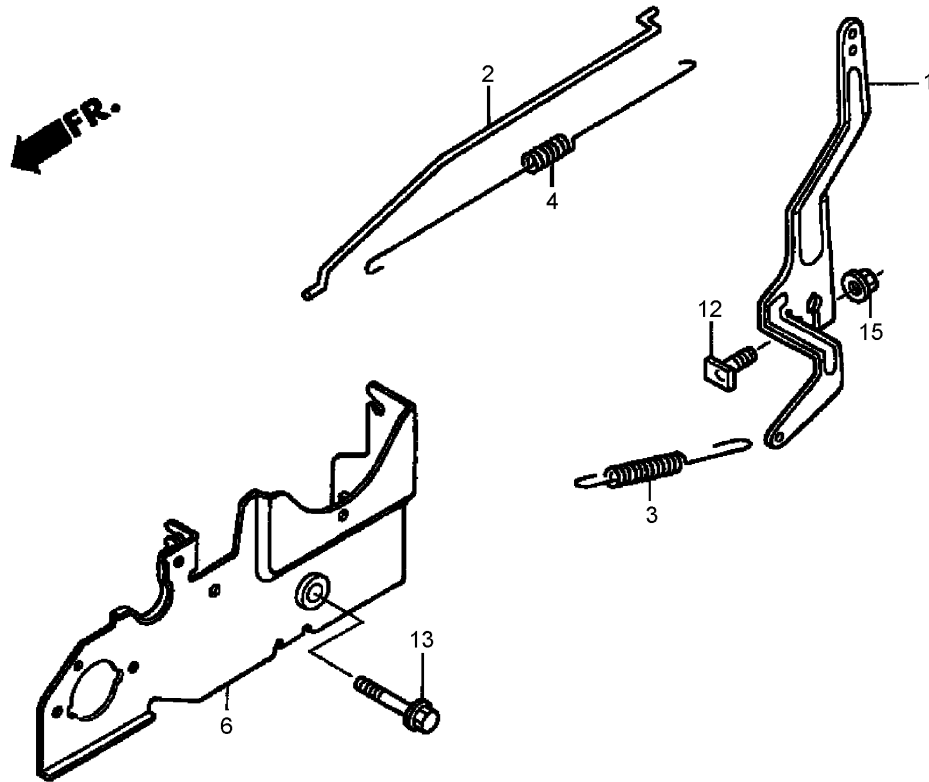

Control Assembly Honda GCV160A STL1

Ref	Part No.	Qty.	Description
❶	16551-ZM0-010	1	Arm-Governor
❷	16555-Z0L-800	1	Rod-Governor
❸	16561-Z0L-000	1	Spring-Governor
❹	16562-ZM0-000	1	Spring-Return, Throttle
❻	16580-Z0L-810	1	Base-Control
❸❷	90015-ZE5-010	1	Bolt-Arm, Governor
❸❸	90016-ZE8-000	1	Bolt-Flange (6X45)
❸❹	94050-06000	1	Nut-Flange (6Mm)

--	--	--	--

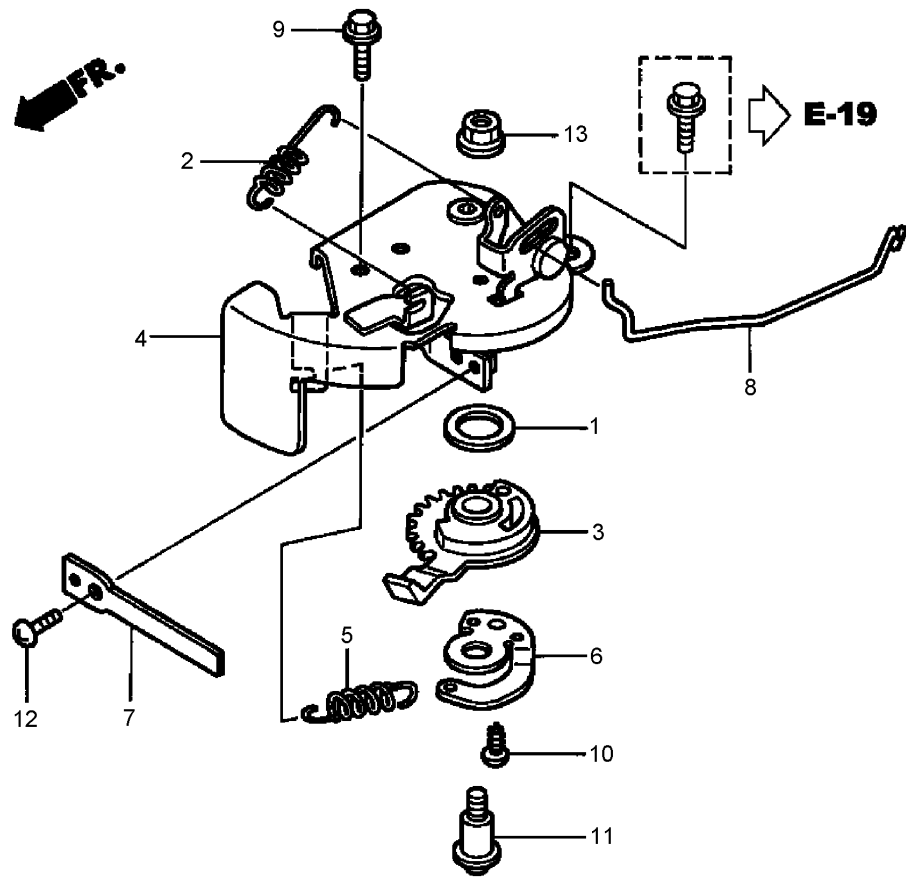

Choke Base Assembly Honda GCV160A STL1

Ref	Part No.	Qty.	Description				
❶	16251-Z0L-800	1	Seal-Lever, Choke				
❷	16592-ZJ1-000	1	Spring-Return, Cable				
❸	16612-Z0L-800	1	Lever-Choke				
❹	16613-Z0L-800	1	Base-Choke				
❺	16614-Z0L-800	1	Spring-Lever, Choke				
❻	16616-Z0L-800	1	Hook-Spring, Choke				
❼	16619-Z0L-800	1	Plate-Choke				
❽	16632-Z0L-800	1	Rod-Stop				
❾	90029-888-000	1	Bolt-Flange (6X16)				
❿	90102-SP1-003	1	Screw-Tapping (4X8) (Po)				
⓫	90141-KT8-000	1	Screw-Pan (5X19)				
⓬	93500-04008-0H	1	Screw-Pan (4X8)				
⓭	94050-05000	1	Nut-Flange (5Mm)				

Attachments and Accessories

For 10695 - Insight Gold Lawn Mower

Product Name	Model/Part
Loose Parts Kit	108-9355
Replacement Bag	89815
Rear Bag Kit	89913
21 In Blade	89914
Cruise Control Kit	89919
Air Filter	89928
Spark Plug	89947

NOTES

NOTES

NOTES

