

LAWN-BOY®

Gold-Series

Walk-Behind Power Mower

Model No. 10415 – 5900001 & Up

Model No. 10420 – 5900001 & Up

Model No. 10515 – 5900001 & Up

Model No. 10520 – 5900001 & Up

Operator's Manual

IMPORTANT: Read this manual carefully. It contains information about your safety and the safety of others. Also become familiar with the controls and their proper use before you operate the product.

Introduction

Thank you for purchasing a Lawn-Boy product.

All of us at Lawn-Boy want you to be completely satisfied with your new product, so feel free to contact your local Authorized Service Dealer for help with service, genuine Lawn-Boy parts, or other information you may require.

Whenever you contact your Authorized Service Dealer or the factory, always know the model and serial numbers of your product. These numbers will help the Service Dealer or Service Representative provide exact information about your specific product. You will find the model and serial number decal located in a unique place on the product as shown below.

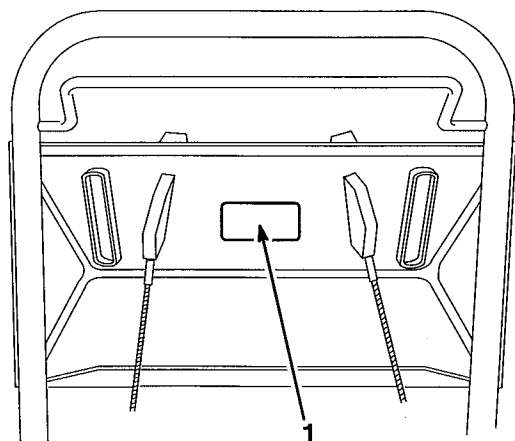

1. Model and Serial Number Decal

For your convenience, write the product model and serial numbers in the space below.

Model No. _____
Serial No. _____

Read this manual carefully to learn how to operate and maintain your product correctly. Reading this manual will help you and others avoid personal injury and damage to the product. Although Lawn-Boy designs, produces and markets safe, state-of-the-art products, you are responsible for using the product properly and safely. You are also responsible for training persons who you allow to use the product about safe operation.

The Lawn-Boy warning system in this manual identifies potential hazards and has special safety messages that help you and others avoid personal injury, even death. **DANGER**, **WARNING** and **CAUTION** are signal words used to identify the level of hazard. However, regardless of the hazard, be extremely careful.

DANGER signals an extreme hazard that will cause serious injury or death if the recommended precautions are not followed.

WARNING signals a hazard that may cause serious injury or death if the recommended precautions are not followed.

CAUTION signals a hazard that may cause minor or moderate injury if the recommended precautions are not followed.

Two other words are also used to highlight information. "Important" calls attention to special mechanical information and "Note" emphasizes general information worthy of special attention.

The left and right side of the machine is determined by standing behind the handle in the normal operator's position.

Contents

	Page		Page
Safety	2	Maintenance	15
Safe Operating Practices	2	Recommended Maintenance Schedule ...	15
Safety and Instruction Decals	5	Air Filter	16
Assembly	6	Spark Plug	17
Handle	6	Clean Mower Housing	17
Cover Plate	7	Blade	18
Before Starting	8	Lubrication	20
Oil Mix Ratio	8	Self-propelled Cable	20
Mixing Gasoline And Oil	9	Exhaust Ports	21
Lawn Preparation And Mowing	10	Troubleshooting	23
Operation	11	Accessories	25
Starting Engine	11	Rear Grass Catcher	25
Stopping Engine	12	Mulch Plate	27
Self-propelled Drive	12	Storage	29
Adjusting Cutting Height	13	Fuel	29
Mulching Tips	13	Engine	29
		Folding Handle	30
		Removing From Storage	31
		Maintenance Record	32
		Warranty	Back Cover

Safety

This machine meets or exceeds CPSC blade safety requirements for walk-behind rotary mowers and the B71.1 specifications of the American National Standards Institute, in effect at time of production. However, improper use or maintenance by the operator or owner can result in injury. To reduce the potential for injury, comply with these safety instructions and always pay attention to the safety alert  symbol which means CAUTION, WARNING or DANGER—"personal safety instruction." Failure to comply with the instruction may result in personal injury.

Safe Operating Practices

This product is capable of amputating hands and feet and throwing objects. Always follow all safety instructions to avoid serious injury or death.

 WARNING
POTENTIAL HAZARD <ul style="list-style-type: none">• Engine exhaust contains carbon monoxide, which is an odorless, deadly poison.
WHAT CAN HAPPEN <ul style="list-style-type: none">• Carbon monoxide can kill you and is also known to the State of California to cause birth defects.
HOW TO AVOID THE HAZARD <ul style="list-style-type: none">• Do not run engine indoors or in an enclosed area.

This mower is designed for cutting and mulching grass or, when equipped with a grass bag, for catching cut grass. Any use for purposes other than these could prove dangerous to user or bystanders.

Note: This engine is NOT equipped with a spark arrester muffler. Use or operation of this mower in the State of California on any forest-covered, brush-covered or unimproved grass-covered land, without an approved spark arrester muffler, is a violation of the law. Other states may have similar laws.

General Operation

1. Read this manual carefully before operating the mower. Become familiar with the controls and proper use of the mower. Never allow children under 16 years of age to operate the mower. Never allow adults to operate mower without proper instructions.
2. The operator of the mower is responsible for keeping everyone, especially children and pets, away from area of operation. The operator is responsible for accidents or hazards occurring to other people or their property.
3. Thoroughly inspect area where mower will be used and remove sticks, stones, wire, and debris. Watch for foreign objects while mowing.
4. Wear long pants and substantial shoes. Do not operate mower while wearing open-toed shoes, jewelry, loose clothing or when barefoot.
5. Check fuel level before starting engine. Do not fill fuel tank indoors, when the engine is running, or until engine cools for several minutes after running. Do not smoke while refueling. Wipe up spilled gasoline before starting engine.
6. Keep all guards, shields, grass catchers and safety devices in place. Repair or replace damaged parts, including decals. Check all safety devices before each use.

7. Engine, blade and self-propelled drive are designed to stop when control bails are released. Ensure control and brake function properly before each use of mower.
8. Because fuel is highly flammable, handle it carefully.
 - A. Use an approved container.
 - B. Fill fuel tank outdoors, not indoors.
NEVER ADD FUEL TO AN ENGINE THAT IS RUNNING OR HOT.
 - C. Install gas cap on fuel container and gas tank, and wipe up any spilled gasoline before starting engine.
9. Before using, always visually inspect to see that the blades, blade bolts and cutter assembly are not worn or damaged. Replace worn or damaged blades and bolts in sets to preserve balance.
7. Keep face, hands, and feet away from the mower housing and cutter blade when the engine is running. Blade can cause injury to hands and feet.
8. Use extreme caution when reversing or pulling the mower towards you.
9. Stay behind the handle until the engine stops and keep clear of discharge opening at all times.
10. When bagging grass, stop engine and stay behind handle until all moving parts stop before removing and emptying bag.
11. When mowing, ensure grass bag or mulch plate is installed over discharge opening.
12. Shut engine off and stay behind handle until all moving parts stop before unclogging chute.
13. Since the blade rotates for a few seconds after the blade control bail is released, stay behind the handle until all moving parts stop.

While Operating

1. Do not run engine indoors.
2. Do not upend mower when starting engine. If necessary, tilt mower so that blade points away from operator and bystanders.
3. Start the engine carefully according to instructions and with feet well away from the blade.
4. Always maintain secure footing. Keep a firm grip on the handle and walk; never run. Never operate mower in wet grass. Mow only in daylight or in good artificial light.
5. Mow across the face of slopes; never up and down. Use extreme caution when changing direction on slopes. Do not mow excessively steep slopes. Wear skid resistant shoes on slopes.
6. Always wear safety glasses or eye shields during operation to protect eyes from foreign objects that may be thrown from the machine.
14. After striking a foreign object or if mower vibrates abnormally, stop engine and remove wire from spark plug. Check mower for damage and make all repairs before using mower again. If major repairs are ever needed or if assistance is desired, contact your local Authorized Lawn-Boy Service Dealer.
15. Stop the engine and wait for all moving parts to stop before adjusting the height-of-cut.
16. Stop the blade when pushing the mower outside the lawn area.
17. Stop engine before leaving the operator's position – behind the handle. Disconnect wire from spark plug if mower will be unattended.
18. Do not touch engine while it is running or shortly after it is stopped because engine will be hot enough to cause a burn.
19. If mower must be lifted to be transported, turn off engine and stay behind the handle until all moving parts stop.

Maintenance

1. Perform only those maintenance instructions described in this manual. If major repairs are ever needed or if assistance is desired, contact your local Authorized Lawn-Boy Service Dealer.
2. Before mower is cleaned, inspected, serviced, or adjusted, stop engine and disconnect wire from spark plug. Keep wire away from plug to prevent accidental starting.
3. To assure the mower is in safe operating condition, frequently check and keep all nuts, bolts, and screws tight. Assure blade nut is tightened to 560 in.-lbs. (47 ft.-lbs.) (63 N·m).
4. When servicing blade, refer to blade maintenance section for correct installation and servicing procedures.
5. To reduce fire hazard, keep engine free of excessive grease, grass, leaves, and accumulations of dirt.
6. Do not overspeed the engine by changing governor settings.
7. Check grass catcher bag frequently for wear or deterioration. Replace with a new bag when worn or damaged for your protection.
8. Allow engine to cool before storing mower in any enclosure. Do not store mower near any open flame or where gasoline fumes may be ignited by a spark.
9. At the time of manufacture, the mower conformed to the safety standards in effect for rotary mowers. To ensure best performance and continued safety certification of the mower, use genuine Lawn-Boy replacement parts and accessories. Replacement parts and accessories made by other manufacturers may result in nonconformance with the safety standards, and that could be dangerous.

Safety and Instruction Decals



Safety decals and instructions are easily visible to the operator and are located near any area of potential danger. Replace any decal that is damaged or lost.



ON MOWER HOUSING
(Part No. 39-5770)

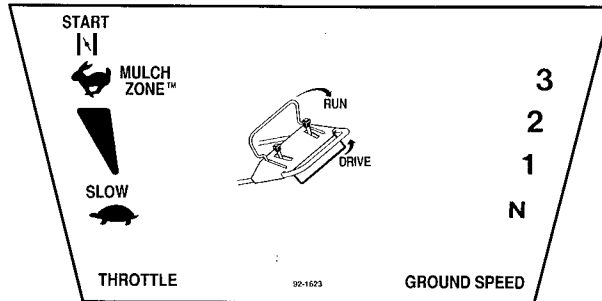

ON CONSOLE
(Part No. 92-1623 Model 10520 only)
(Part No. 92-2902 Models 10415, 10420 and 10515 only)



ON REAR OF CONTROL PANEL
(Part No. 92-2940)



ON MOWER HOUSING
(Part No. 71-1280)

Assembly

Handle

Assembly

1. Loosen handle knobs and lift top handle half in an arc until handle halves are in line and nest together (Fig. 1).

Note: Use care to prevent pinching or stretching of cables.

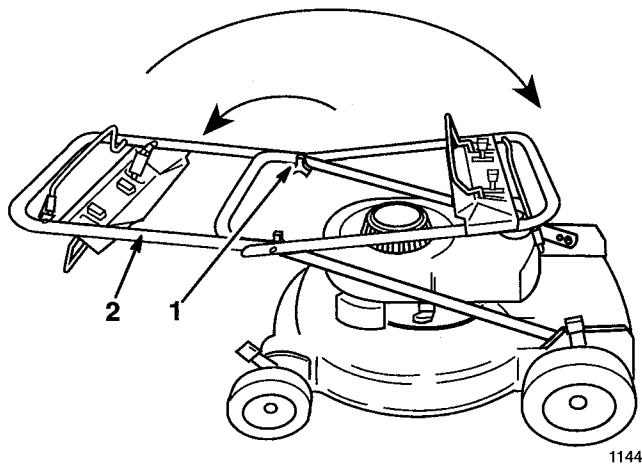

Figure 1

1. Knob
2. Top handle half

2. Tighten knobs securely.
3. Rotate handle toward rear of mower.

Handle Height

Handle may be placed in three (3) operating positions, high, medium or low (Fig. 2). Select a handle height position that is most comfortable for you.

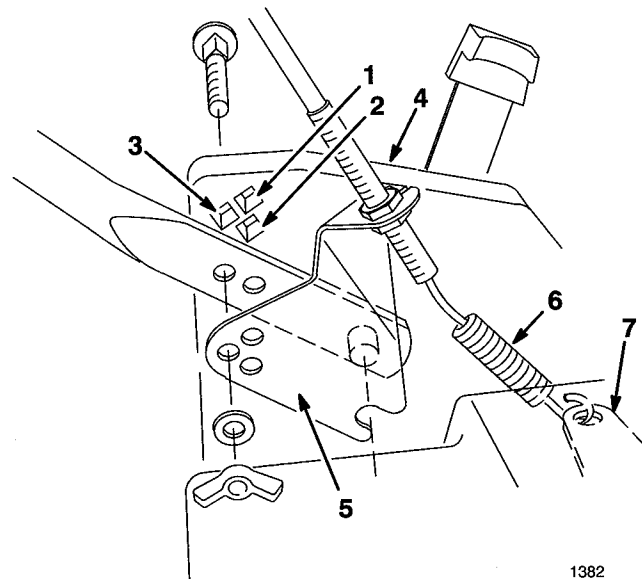

Figure 2

1. High setting
2. Medium setting
3. Low setting
4. Mower housing
5. Traction cable bracket
6. Traction cable spring
7. Actuator bracket

1. Align holes in lower handle section with holes in mower housing. Using hardware shown in Figure 2, secure handle to mower housing.

(Self-propelled Models Only)

1. Hook traction cable spring into actuator bracket as shown in Figure 2.
2. Match three (3) holes in traction cable bracket to three (3) holes in left side of mower housing. Secure bracket with handle hardware (Fig. 2).

Cover Plate

Your mower was shipped with a cover plate (Fig. 4). For side discharge operation the plate must be installed into deck opening.

WARNING

POTENTIAL HAZARD

- An uncovered discharge opening will allow objects to be thrown in operator's or bystander's direction. Also, contact with blade could occur.

WHAT CAN HAPPEN

- Thrown objects or blade contact can cause serious injury.

HOW TO AVOID THE HAZARD

- Never operate mower unless cover plate, mulch plate or grass chute and catcher are installed.

1. Stop engine and disconnect spark plug wire (Fig. 3) before installing or removing cover plate.

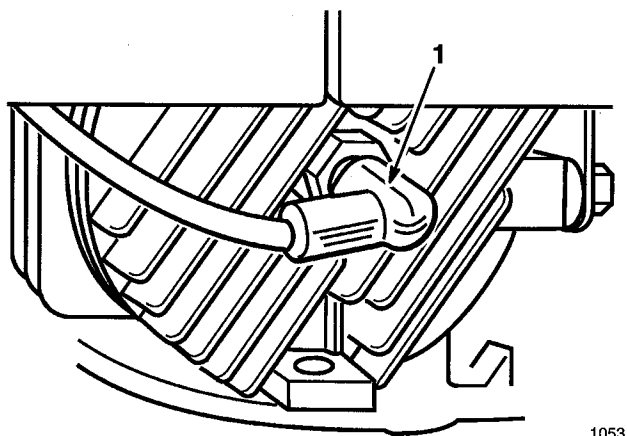

Figure 3

1053

1. Spark plug wire
2. Remove wing screw that fastens cover plate to the housing (Fig. 4).

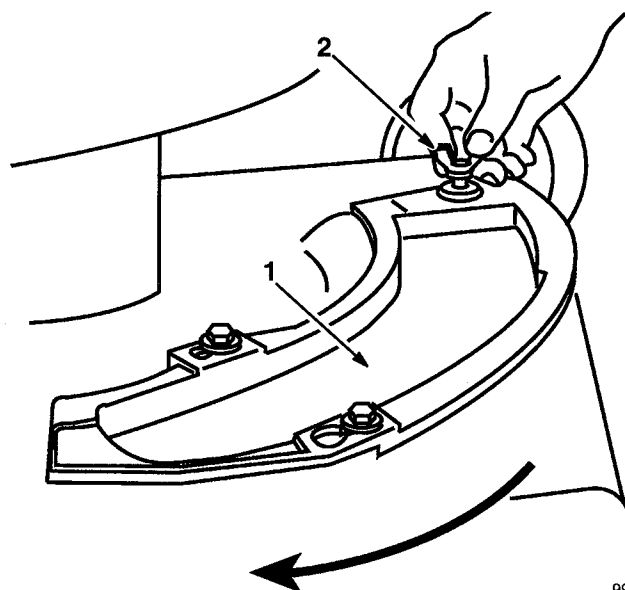

Figure 4

996

1. Cover plate
2. Wing screw

3. Two shoulder bolts on the housing protrude through slotted holes in the cover plate and do not have to be loosened or removed. Cover plate moves over the shoulder bolt heads (Fig. 5).

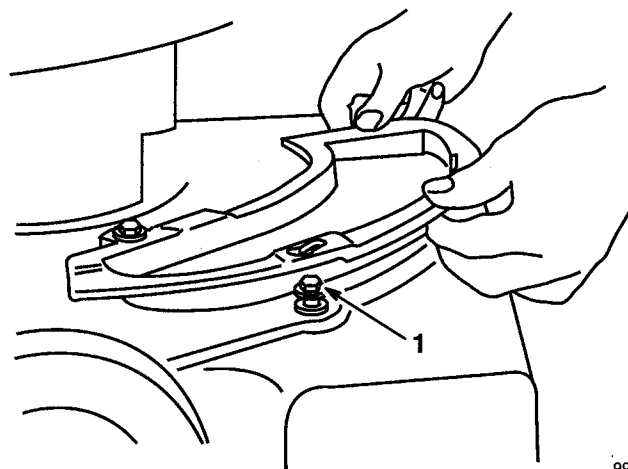

Figure 5

995

1. Shoulder bolt
4. Slide cover plate clockwise to install or counterclockwise to remove.
5. Secure with wing screw.
6. Connect spark plug wire (Fig. 3).

Before Starting

Oil Mix Ratio

Your Lawn-Boy mower is powered by a 2-cycle engine which requires a mixture of gasoline and oil; **32:1 with Lawn-Boy® 2-CYCLE ASHLESS OIL.** Failure to use the right mixture will result in serious engine damage.

Use Lawn-Boy 2-CYCLE ASHLESS OIL (Fig. 6), which is formulated specifically for Lawn-Boy and is available from your Lawn-Boy retailer. Regular use of Lawn-Boy 2-CYCLE ASHLESS OIL will help keep your engine clean, reduce spark plug fouling, piston ring sticking and pre-ignition. Lawn-Boy 2-CYCLE ASHLESS OIL will also minimize varnish build-up, combustion chamber deposits and exhaust port blockage.

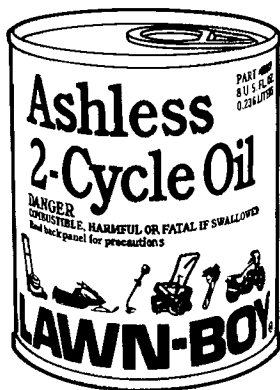

Figure 6

1057

If Lawn-Boy 2-CYCLE ASHLESS OIL is not available, other premium grade 2-CYCLE ASHLESS OILS can be substituted. Substitute oils may produce more exhaust smoke and require increased engine service including more frequent spark plug changes, exhaust port/cylinder decarbonizing and could reduce engine life.

Note: NEVER USE AUTOMOTIVE OIL (i.e. SAE 30, 10W30 etc.), OR THE WRONG MIX RATIO BECAUSE ENGINE DAMAGE MAY OCCUR. If engine failure occurs and it has been determined that Lawn-Boy 2-CYCLE ASHLESS OIL was not used, the failure may not be covered by the Lawn-Boy warranty.

DANGER

POTENTIAL HAZARD

- In certain conditions gasoline is extremely flammable and highly explosive.

WHAT CAN HAPPEN

- A fire or explosion from gasoline can burn you, others, and cause property damage.

HOW TO AVOID THE HAZARD

- Use a funnel and fill the fuel tank outdoors, in an open area, when the engine is cold. Wipe up any gasoline that spills.
- Do not fill the fuel tank completely full. Add gasoline to the fuel tank until the level is 1/4" to 1/2" (6 mm to 13 mm) below the bottom of the filler neck. This empty space in the tank allows gasoline to expand.
- Never smoke when handling gasoline, and stay away from an open flame or where gasoline fumes may be ignited by a spark.
- Store gasoline in an approved container and keep it out of the reach of children.
- Never buy more than a 30-day supply of gasoline.

Mixing Gasoline And Oil

For simplicity and best engine performance, mix 8 ounces of Lawn-Boy 2-CYCLE ASHLESS OIL with two gallons of fresh, unleaded regular gasoline. Pour one gallon of gasoline into an approved gasoline container and add the correct amount of 2-cycle oil. Install cap on gasoline container and shake to mix oil and gasoline thoroughly (Fig. 7). Slowly remove cap and add remaining gasoline.

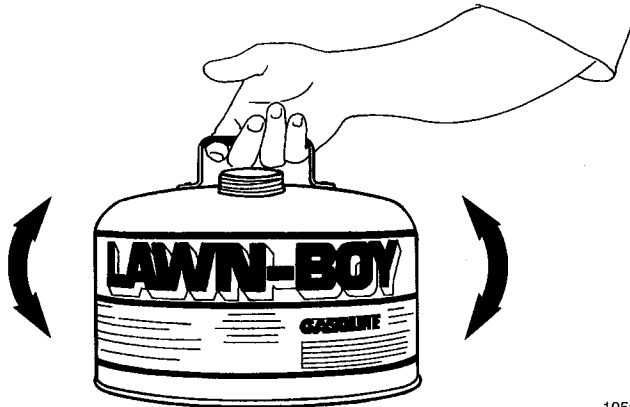

Figure 7

1056

Note: Do not mix gasoline and oil in the product fuel tank. Oil that is at room temperature mixes easily and more thoroughly than cold oil.

Use clean, fresh lead-free gasoline with an octane rating of 85 or higher. Purchase only the quantity of gasoline that can be used in 30 days to assure freshness. Use of lead-free gasoline results in fewer combustion chamber deposits and longer spark plug life. Leaded gasoline may be used if lead-free is not available.

Note: NEVER USE METHANOL, GASOLINE CONTAINING METHANOL, GASOHOL CONTAINING MORE THAN 10% ETHANOL, PREMIUM GASOLINE OR WHITE GAS BECAUSE ENGINE FUEL SYSTEM COULD BE DAMAGED.

1. Clean around fuel cap before removing (Fig. 8). Fill fuel tank with gasoline/oil mix to within 1/4 inch (6.5 mm) of top of tank, not into filler neck. DO NOT OVER-FILL TANK. Replace fuel cap securely and wipe up any spilled fuel.

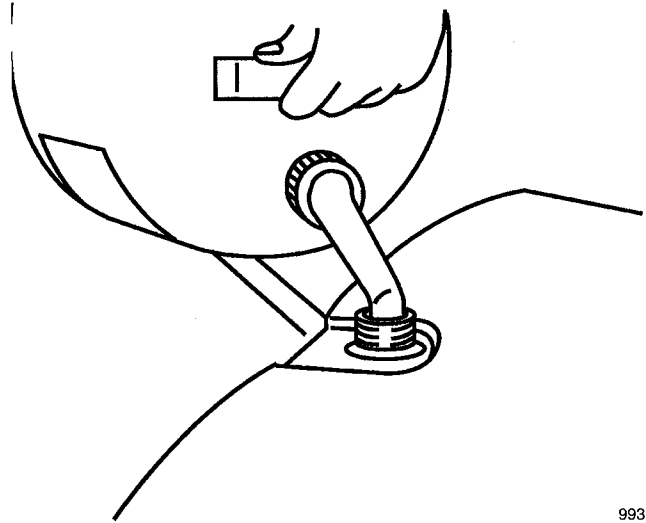

Figure 8

993

Lawn-Boy recommends that Lawn-Boy 2+4® Fuel Conditioner (Fig. 9) be used regularly during operation and storage. Lawn-Boy 2+4® Fuel Conditioner cleans the engine during operation and prevents gum-like varnish deposits from forming in the engine during storage.

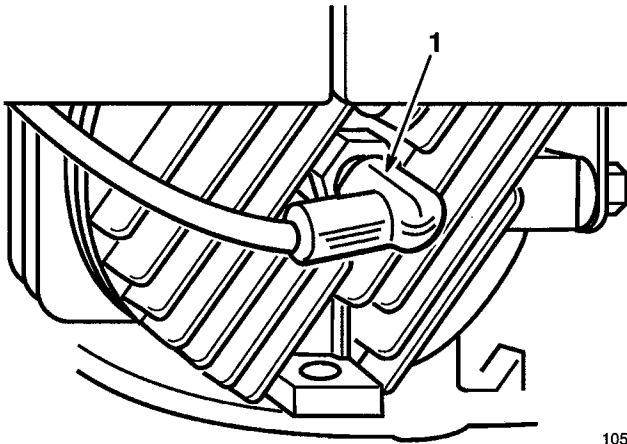

Figure 9

1058

DO NOT USE FUEL ADDITIVES OTHER THAN THOSE MANUFACTURED FOR FUEL STABILIZATION DURING STORAGE, SUCH AS LAWN-BOY 2+4® FUEL CONDITIONER. LAWN-BOY DOES NOT RECOMMEND STABILIZERS WITH AN ALCOHOL BASE SUCH AS ETHANOL OR METHANOL. STABILIZERS SHOULD NOT BE USED TO TRY TO ENHANCE THE POWER OR PERFORMANCE OF MACHINE.

2. Connect spark plug wire (if disconnected) (Fig. 10).



1053

Figure 10

1. Spark plug wire
-

Lawn Preparation And Mowing

1. Review SAFETY INSTRUCTIONS and read this manual carefully before operating mower.
2. Clear area of sticks, stones, wire, branches and other debris which could be picked up or hit by cutting blade and become thrown objects.
3. Keep everyone, especially children and pets, away from area of operation.
4. Avoid striking trees, walls, curbs or other solid objects. Never deliberately mow over any object.
5. If an object is struck, or mower starts to vibrate, immediately stop engine, disconnect spark plug wire and examine mower for damage.
6. Replace blade when necessary with an original Lawn-Boy replacement blade.

Operation

Starting Engine

Note: Follow steps in BEFORE STARTING section.

1. Open fuel shut off valve (Fig. 11).

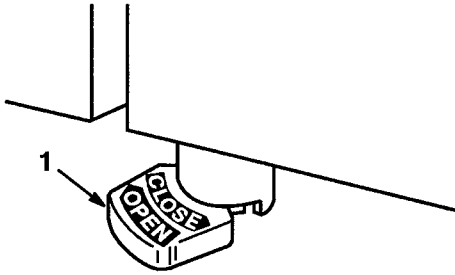



Figure 11

1. Fuel shut off valve

2. Move throttle lever to FAST  position (Fig. 12).

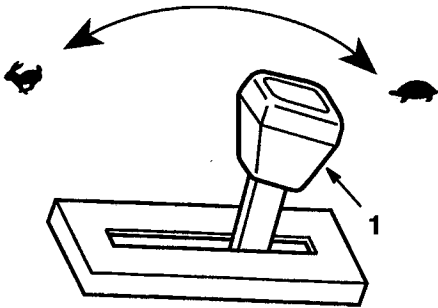

Figure 12

1. Throttle lever

3. Push primer three (3) times (Fig. 13). Wait about two (2) seconds between each push.

Note: Do not use primer to restart a warm engine after a short shutdown.

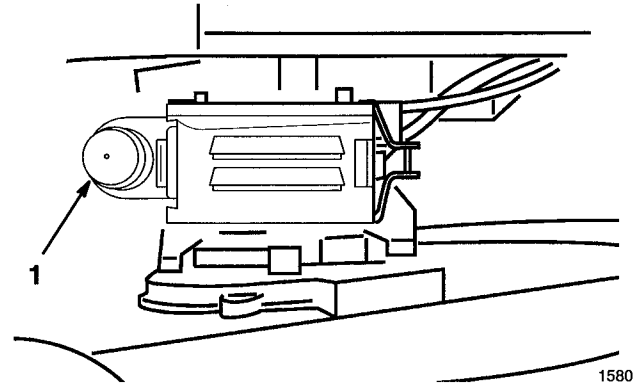

Figure 13

1. Primer

4. Hold blade control bail against upper handle (Fig. 14).

5. Pull starter handle (Fig. 14) lightly until resistance is felt, then pull sharply. Let rope return to handle slowly.

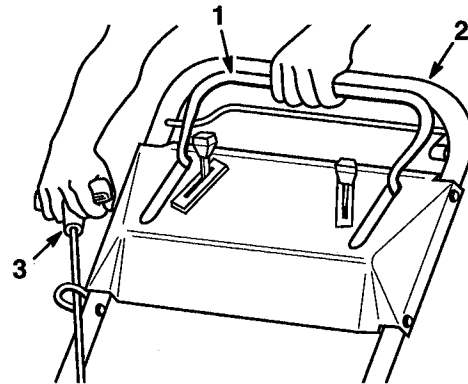

Figure 14

1. Blade control bail
2. Upper handle
3. Starter handle

Note: If engine fails to start after three (3) pulls, repeat steps 2-5.

Stopping Engine

1. Release blade control bail (Fig. 15). Both the engine and blade will stop. See your dealer immediately if they do not.

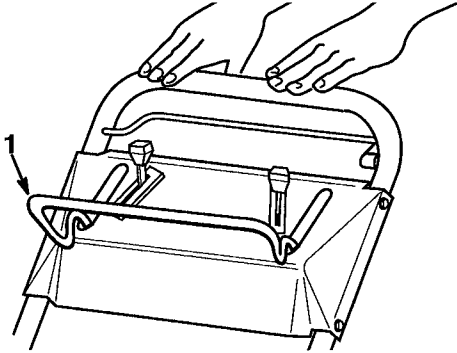



Figure 15

1046

1. Blade control bail

To Restart Engine

1. Move throttle lever to FAST  position and repeat steps 4 and 5 in STARTING ENGINE procedure.
2. If engine does not start after two attempts, repeat steps 3–5 in STARTING ENGINE procedure.

Note: Do not use primer to restart a warm engine after a short shutdown.

Self-propelled Drive

(self-propelled models only)

1. Move ground speed lever to one (1) of three (3) ground speeds, **1** – slow, **2** – medium or **3** – fast. Select a speed that is comfortable to walk and not too fast for grass length.

Note: Do not change ground speeds with self-propelled drive engaged. Stop mower, place ground speed lever in desired position, then continue mowing.

2. Move ground speed lever to **N** – neutral when trimming or leaving mower.
3. To operate self-propelled drive squeeze self-propelled bail against handle and hold (Fig. 16).

Note: Slight variations in ground speed can be made by increasing space between self-propelled bail and handle.

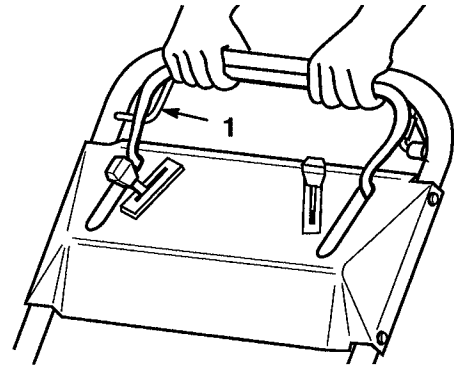

Figure 16

1048

1. Self-propelled bail

4. To disengage self-propelled drive, release self-propelled bail (Fig. 17).

Note: Mower is equipped with free-wheeling clutches which make it easier to pull the mower rearward. To disengage clutches mower may need to be pushed forward one inch or more after self-propelled bail has been released.

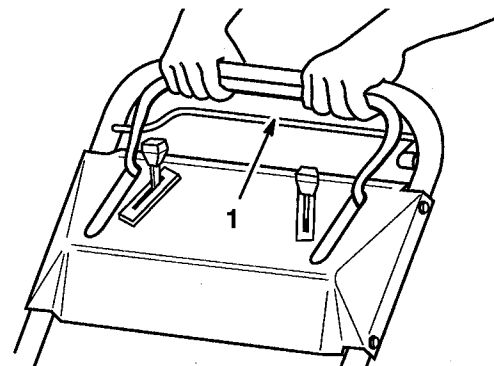

Figure 17

1047

1. Self-propelled bail

Adjusting Cutting Height

Each wheel is adjusted individually with a wheel height adjustment lever. Cutting heights are 1", 1-1/2", 2", 2-1/2", 3" and 3-1/2 inches (25, 38, 51, 64, 74 and 86 mm).

DANGER

POTENTIAL HAZARD

- Adjusting height-of-cut levers could bring hands into contact with moving blade.

WHAT CAN HAPPEN

- Contact with rotating blade can cause serious injury.

HOW TO AVOID THE HAZARD

- Stop engine and wait for all movement to stop before adjusting cutting height.
- Do not put fingers under housing when adjusting height-of-cut.

1. To change cutting height pull wheel height adjustment lever toward wheel and move to the desired position (Fig. 18).

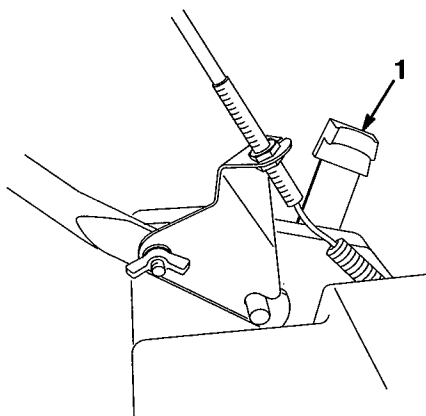

Figure 18

1. Wheel height adjustment lever

2. Release wheel height adjustment lever and seat securely in notch.

Note: Set all four (4) wheels at the same height.

Mulching Tips

General Tips

Follow these instructions whether cutting grass or leaves for the best cutting results and lawn appearance:

- Maintain a **sharp blade** throughout the cutting season. Periodically file down nicks on blade.
- Only mow dry grass or leaves. Wet grass and leaves tend to clump on yard and may cause mower to plug or engine to stall. They may also be slippery to walk on and could cause you to slip and fall.

WARNING

POTENTIAL HAZARD

- Wet grass or leaves can cause you to slip and contact blade.

WHAT CAN HAPPEN

- Blade contact can seriously injure you.

HOW TO AVOID THE HAZARD

- Mow only in dry conditions.

- Set engine speed to fastest position. Maximum horsepower provides best cutting results.
- Clean clippings or leaves from underside of mower deck after each mowing.
- Keep engine in good running condition. Cutting and recutting requires more horsepower.
- Clean air filter more frequently. Cutting and recutting stirs up more clippings and dust which clogs the air filter and reduces engine performance.

Cutting Grass

- Grass grows at different rates at different times of the year. In the heat of summer, it is generally best to cut grass at the 2, 2.5 or 3 inch height-of-cut settings. Only about $\frac{1}{3}$ of the grass blade should be cut off. Cutting below the 2 inch setting is not recommended unless grass is sparse or it is late fall when grass growth begins to slow down.
- When cutting grass over six inches tall, you may want to first mow using the highest height-of-cut setting and a slower walking speed; then mow again at a lower setting for best lawn appearance. If grass is too long and leaves clumps on top of lawn, mower may plug and cause engine to stall.
- Alternate mowing direction. This helps disperse clippings over lawn for even fertilization.

If the finished cut lawn appearance is unsatisfactory, try one or more of the following:

- Sharpen the blade.
- Walk at a slower pace while mowing.
- Raise the height-of-cut setting on your mower.
- Cut grass more frequently.
- Overlap cutting swaths instead of cutting a full swath with each pass.

Cutting Leaves

- When cutting is complete, always be sure that 50% of the lawn shows through the cut leaf cover. This may require one or more passes over the leaves.
- Walk at a slower mowing speed if leaves are not being cut up finely enough to be hidden down in the grass.
- If you cut up a lot of oak leaves, you might want to add lime to your grass in the spring. Lime reduces the acidity of oak leaves.

Maintenance

Continued safe and dependable operation requires routine maintenance.

Recommended Maintenance Schedule

Service Item	Service Operation	After every use	5 Hours	25 Hours	50 Hours	100 Hours
Housing	Clean built-up grass clippings and dirt.	X				
Fasteners	Check blade and engine mounting fasteners frequently. Keep all nuts, bolts and screws tight to ensure safe operation.		X			
Air Filter	Remove and clean each mowing season or every 25 hours. Clean more frequently if operating conditions are dusty.			X		
Spark Plug	Clean, inspect and gap. Replace if necessary.			X		
Blade	Sharpen or replace; maintain more frequently if edge is dulled quickly in rough or sandy conditions.				X	
Blade Brake	Check stopping time every 50 hours or at start of each mowing season. Blade must stop within 3 seconds of releasing bail; if not see your Authorized Lawn-Boy Service Dealer for repair.				X	
Exhaust Ports	Clean every 50 hours or at least once each mowing season.				X	
Fuel System	Check for leakage and/or deterioration of fuel hose. Replace if necessary.				X	
Cooling System	Clean grass clippings, debris or dirt that clog engine air cooling fins and starter. Clean more frequently under dirty or high chaff conditions.					X

⚠ CAUTION

POTENTIAL HAZARD

- If you leave the wire on the spark plug, someone could start the engine.

WHAT CAN HAPPEN

- Accidental starting of engine could seriously injure you or other bystanders.

HOW TO AVOID THE HAZARD

- Pull wire off spark plug before you do any maintenance. Also push wire aside so it does not accidentally contact spark plug.

Air Filter

Clean air filter once every season or every 25 hours; clean more frequently under dusty conditions.

Note: Do not operate engine without air filter element; extreme engine wear or damage will occur.

1. To remove air filter, snap cover latch open, swing to side and unhook (Fig. 19).

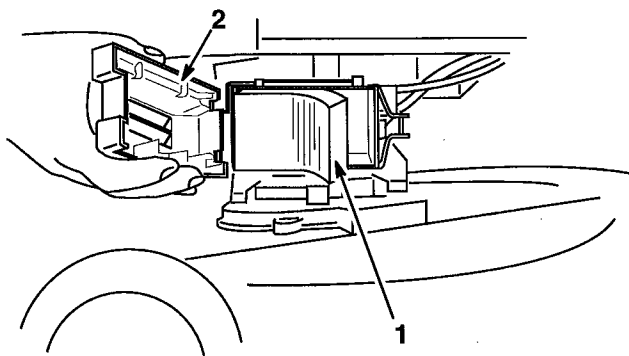

Figure 19

1. Filter
2. Cover

1579

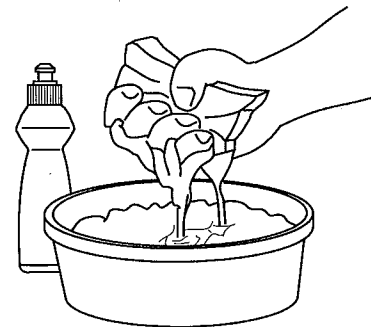

Figure 20

988

5. Apply one tablespoon of SAE 30W oil to the air filter (Fig. 21).

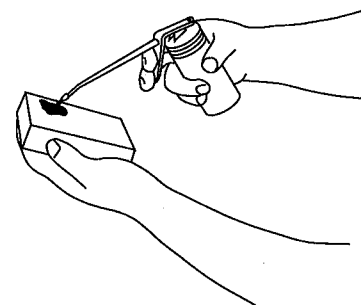

Figure 21

989

2. Remove cover and air filter.
3. Wash air filter in laundry detergent or kerosene (Fig. 20).
4. Squeeze filter to remove excess liquid and blot dry with a paper towel or rag.

6. Squeeze until oil is distributed evenly throughout filter. Blot lightly with paper towel to remove excess oil.
7. Replace filter with cleaner side facing carburetor.

Note: Be sure filter is fully seated in air box and does not pucker, allowing direct passage of air and dirt.

Spark Plug

A spark plug that is dirty, pitted, carbon-covered or has worn electrodes may cause hard starting and poor operation.

Replace spark plug once a season or clean every 25 hours, whichever occurs first. Use a Champion RJ12C spark plug or equivalent.

1. Pull wire off spark plug. Remove spark plug and clean with a wire brush, removing carbon build-up. **DO NOT SAND BLAST.** Check condition of plug for cracks and damaged or worn electrodes. Replace if necessary.
2. Set spark plug gap at .035 inch (.85 mm) (Fig. 22).

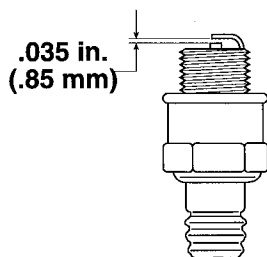

Figure 22

3. Install spark plug by hand, then torque to 180 in.-lbs. (15 ft.-lbs.) (20 N·m) (Fig. 23).

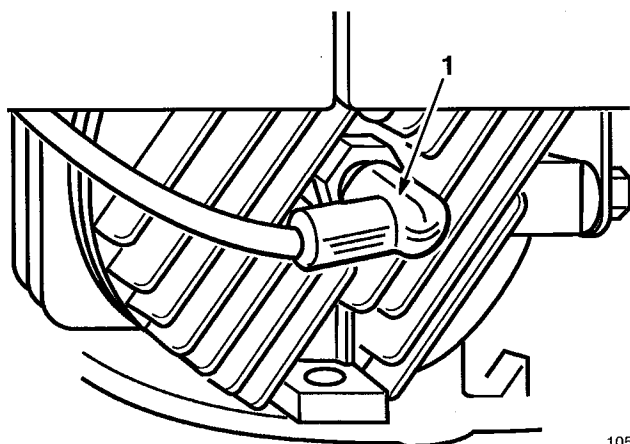

Figure 23

1. Spark plug wire

4. Reconnect spark plug wire when maintenance is completed (Fig. 23).

Clean Mower Housing

A clean mower housing provides the best cutting performance. Check for grass build-up and clean after each use.

1. Disconnect spark plug wire (Fig. 23).
2. Tip mower onto right side (Fig. 24).

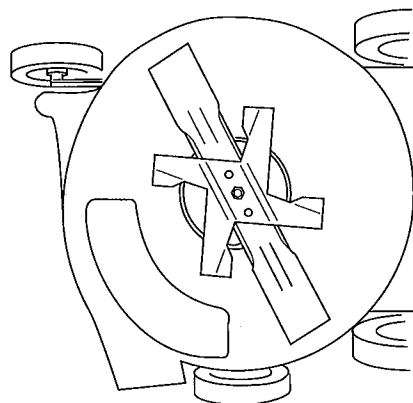

Figure 24

1036

WARNING

POTENTIAL HAZARD

- Gasoline is extremely flammable, highly explosive and under certain conditions can cause personal injury or property damage.

WHAT CAN HAPPEN

- Tipping mower may cause fuel leakage from carburetor or fuel tank.

HOW TO AVOID THE HAZARD

- Avoid fuel spills by running engine dry or remove gas with hand pump, never siphon.

3. Scrape built-up grass clippings and dirt from mower housing with a hardwood scraper.
4. Reconnect spark plug wire when maintenance is completed.

Blade

A straight, sharp blade provides maximum cutting performance. Regularly inspect and sharpen blade.

WARNING

POTENTIAL HAZARD

- Blade is sharp.

WHAT CAN HAPPEN

- Contact with sharp blade can cause serious personal injury.

HOW TO AVOID THE HAZARD

- Wear gloves or wrap sharp edges of the blade with a rag.

Blade Straightness

1. Disconnect spark plug wire (Fig. 23).
2. Measure the distance from the bottom edge of the mower housing to the blade tip (Fig. 25). Rotate the blade 180° and measure to other blade tip.

Note: If measurements are not within 1/8 inch (3.2 mm), blade should be replaced. If, after blade replacement, the measurements are still not within 1/8 inch (3.2 mm), the crankshaft should be checked for straightness by your Authorized Lawn-Boy Service Dealer.

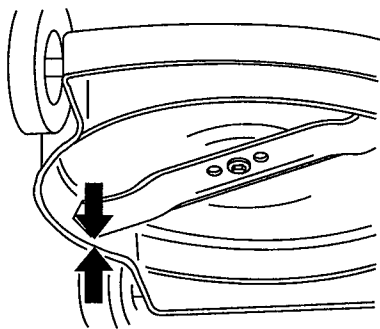

Figure 25

1005

Blade Removal

1. Remove blade nut and mulching fan (Fig. 26).

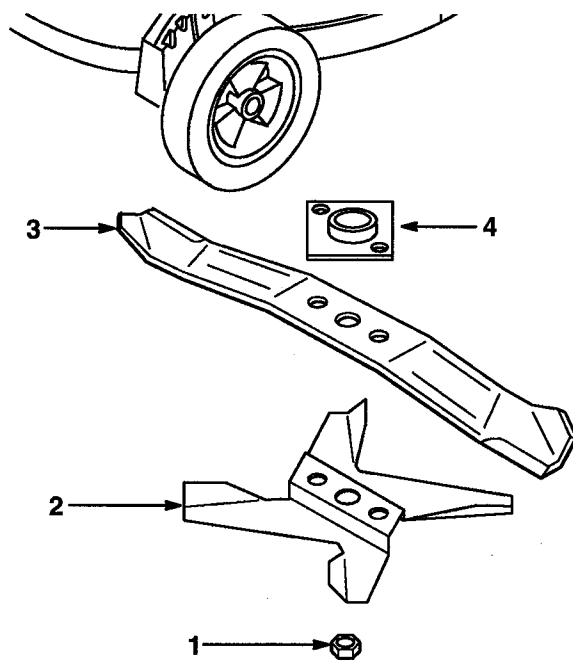

Figure 26

1022

- | | |
|-----------------|-----------------|
| 1. Blade nut | 3. Blade |
| 2. Mulching fan | 4. Blade driver |

2. Remove blade from blade driver (Fig. 26).
3. Examine blade cutting edges for nicks, cutting angle and sharpness. Sharpen or replace if necessary.
4. Examine mulch fan for worn or bent blades. Replace if necessary.
5. Examine blade driver for bent or sheared drive lugs. Replace if necessary.

Blade Sharpening

WARNING

POTENTIAL HAZARD

- When sharpening blade, pieces of blade could be accidentally thrown.

WHAT CAN HAPPEN

- Thrown objects can cause serious eye injury.

HOW TO AVOID THE HAZARD

- Wear proper eye protection when sharpening blade.

1. Sharpen only the leading edge of blade with a file or grinder. Do not sharpen beyond the recommended area.

Note: Blade should not be ground more than 5 inches (127 mm) from outside ends and no less than 2 inches (51 mm) from trailing edge (Fig. 27).

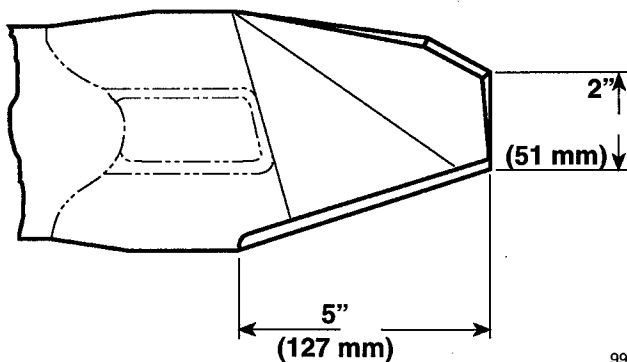

990

Figure 27

Blade Balancing

1. Check the balance of blade by placing the center hole of blade over a nail or screwdriver shank clamped horizontally in a vise (Fig. 28).
2. If either end of blade rotates downward, grind or file that end (not the cutting edge). Blade is properly balanced when neither end drops.

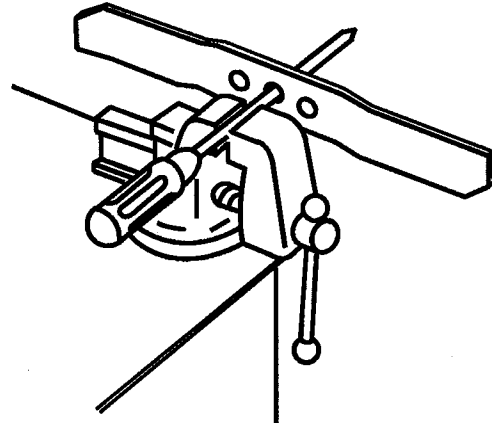

1007

Figure 28

Blade Installation

1. Install blade driver onto crankshaft (if removed) (Fig. 26).
2. Locate blade over lugs of blade driver with curved ends toward mower housing.
3. Install mulch fan into blade recess and secure with blade nut (Fig. 29).

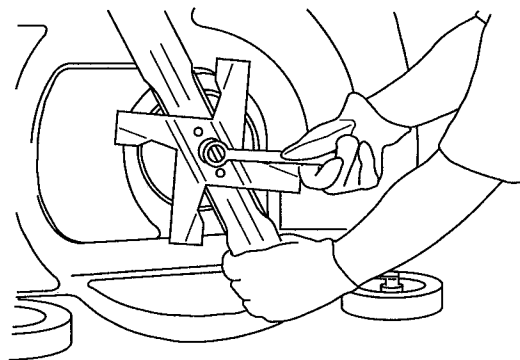

1024

Figure 29

- Torque blade nut to 560 in.-lbs. (47 ft.-lbs.) (63 N·m).

Note: Blade nut must be replaced after installing and removing four (4) times. Locking feature will decrease and nut could loosen if not replaced.

- Connect spark plug wire when maintenance is completed (Fig. 23).

Lubrication

Rear Height Adjusters

(self-propelled models only)

- Wipe grease fittings on rear height-of-cut adjusters (Fig. 30) with a clean rag.
- Install grease gun onto fitting and gently apply 1 or 2 pumps of #2 multi-purpose lithium grease. Excess grease may damage seals and prevent proper wheel clutch operation.

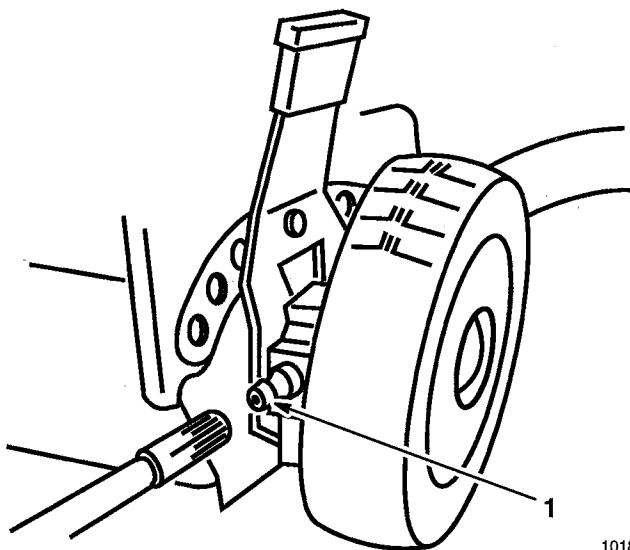

Figure 30

- Grease fitting

1018

Self-propelled Cable

(self-propelled models only)

Whenever handle height is changed, a new self-propelled cable is installed or traction drive belt slips, adjustment is required.

Self-propelled cable is adjusted at the left handle bracket by moving cable jacket held by jam nuts.

- Hold self-propelled bail 1 to 1 1/2 in. (25 to 38 mm) from handle (Fig. 31).

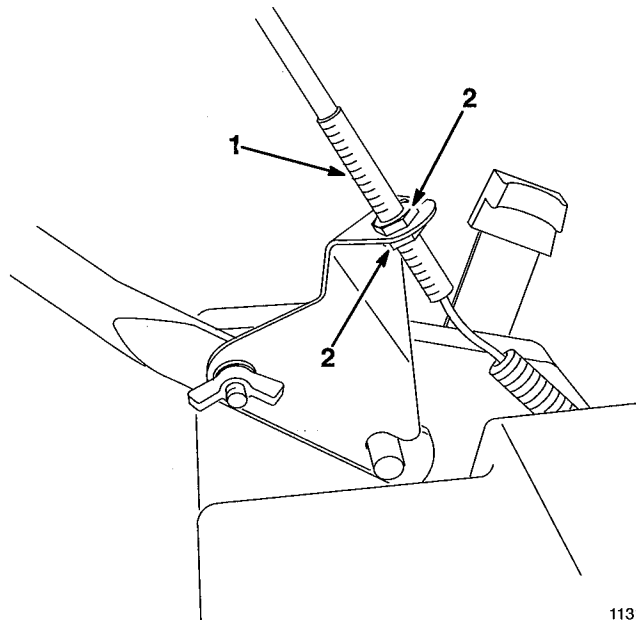

1131

Figure 31

- Cable jacket
- Jam nut

- Adjust jam nuts, at handle bracket, so cable is tight, but spring is not stretched.
- Tighten jam nuts securely.
- Release bail and check to see that cable is loose.

Note: Cable must be loose with bail in released position or mower may creep when bail is disengaged.

Exhaust Ports

Carbon deposit build-up causes excessive wear and loss of power. Check and clean if necessary.

1. Remove spark plug and tip mower on its right side. See SPARK PLUG.
2. Remove blade nut, mulch fan and blade. See BLADE REMOVAL.
3. Remove blade driver by tapping with plastic or fiber hammer in the direction of rotation (Fig. 32). This will loosen the blade driver from taper on crankshaft.

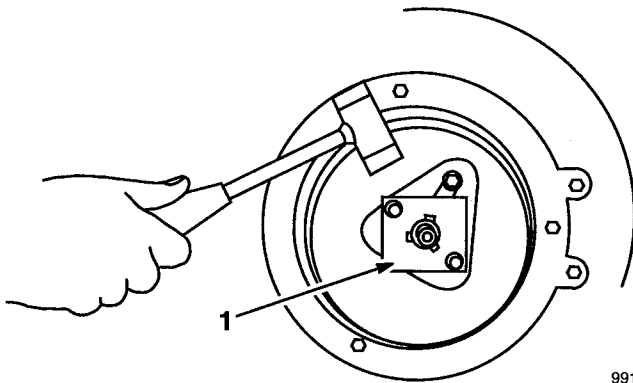

Figure 32

1. Blade driver

4. Remove bolts attaching muffler and crankshaft support (Fig. 33).

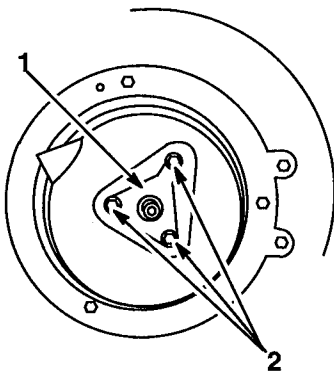

Figure 33

1. Crankshaft support
2. Bolts

5. Rotate crankshaft slowly until piston covers exhaust ports (Fig. 34).

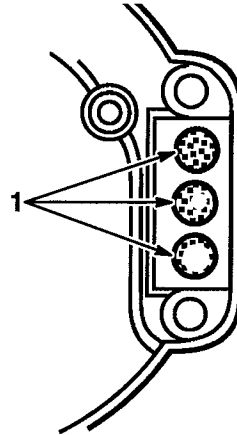

Figure 34

1. Exhaust ports

6. Using a 3/8 inch wooden dowel loosen carbon deposits by inserting dowel into ports.

Note: Do not use metal tools; they could scratch piston.

7. Set mower upright.
8. Holding blade control bail against handle pull starter rope several times to blow out loose carbon (Fig. 35).

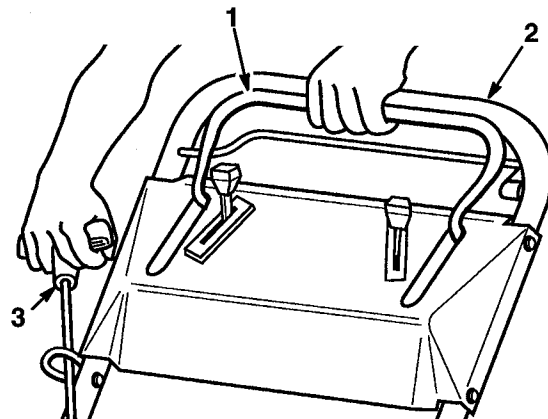

Figure 35

1. Blade control bail
2. Upper handle
3. Starter handle

9. Clean carbon deposits from muffler and tube with wire brush and wood dowel (Fig. 36). Wipe muffler clean with paper towel or rag.

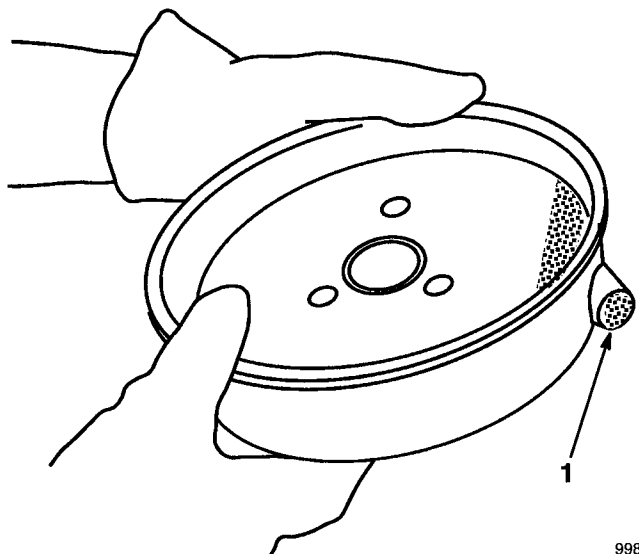

Figure 36

1. Tube

10. Install muffler and crankshaft support to engine mounting plate (Fig. 37).

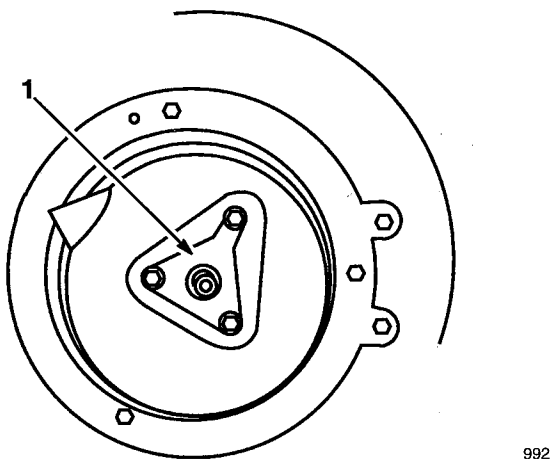

Figure 37

1. Crankshaft support

11. Torque muffler bolts to 155 in.-lbs. (13 ft.-lbs.) (18 Nm).
12. Attach blade driver, blade and mulch fan with blade nut. See BLADE INSTALLATION.
13. Torque blade nut to 560 in.-lbs. (47 ft.-lbs.) (63 N·m).
14. Connect spark plug wire when maintenance is completed.

Note: Crankshaft support must have equal clearance around crankshaft circumference to prevent contact with crankshaft.

Troubleshooting

Your mower was designed and built for trouble-free operation. Check the following components and items carefully. If a problem continues, see your Authorized Lawn-Boy Service Dealer.

PROBLEM	CORRECTIVE ACTION
Engine will not start	<ol style="list-style-type: none"> 1. Fill fuel tank with fresh gasoline/oil mix 2. Move throttle lever to the START position 3. Press primer three (3) times 4. Spark plug <ul style="list-style-type: none"> • Connect spark plug wire • Clean spark plug, check spark plug gap, replace if damaged
Engine starts hard or loses power	<ol style="list-style-type: none"> 1. Drain and refill fuel tank with fresh gasoline/oil mix 2. Clean gas cap vent hole 3. Clean or replace air filter element 4. Clean mower discharge chute 5. Clean underside of mower deck 6. Clean spark plug, check spark plug gap, replace if damaged
Engine runs rough	<ol style="list-style-type: none"> 1. Connect spark plug wire 2. Clean spark plug, check spark plug gap, replace if damaged 3. Move throttle lever from SLOW to FAST position 4. Clean or replace air filter element
Mower or engine vibrates excessively	<ol style="list-style-type: none"> 1. Balance blade 2. Tighten blade mounting nut 3. Clean mower discharge chute 4. Clean underside of mower deck 5. Tighten engine mounting bolts
Uneven cutting pattern	<ol style="list-style-type: none"> 1. Place all four (4) wheels at same height 2. Sharpen and balance blade 3. Change mowing pattern 4. Clean underside of mower deck

PROBLEM	CORRECTIVE ACTION
Discharge chute plugs	<ol style="list-style-type: none">1. Move throttle lever from SLOW to FAST position2. Raise cutting height3. Allow grass to dry before mowing4. Clean underside of mower deck
Will not self-propel	<ol style="list-style-type: none">1. Adjust self-propelled cable

Accessories

Optional accessories may have been shipped with your mower or are available from your Authorized Lawn-Boy Dealer. For proper installation follow these instructions.

Rear Grass Catcher

WARNING

POTENTIAL HAZARD

- An uncovered discharge opening will allow objects to be thrown in operator's or bystander's direction. Also, contact with blade could occur.

WHAT CAN HAPPEN

- Thrown objects or blade contact can cause serious injury.

HOW TO AVOID THE HAZARD

- Never operate mower unless cover plate, mulch plate or grass chute and catcher are installed.

1. Stop engine and disconnect spark plug wire (Fig. 38) before installing or removing grass chute.

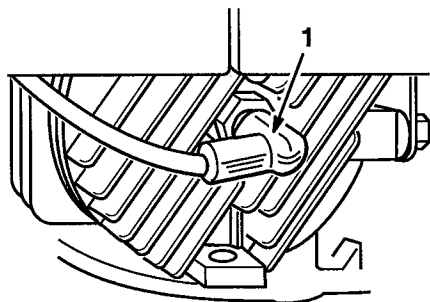

Figure 38

1053

1. Spark plug wire
2. Place chute assembly into housing opening (Fig. 39).

Two shoulder bolts on the mower housing protrude through slotted holes in the chute assembly and do not have to be loosened or removed. Chute assembly moves over the shoulder bolts.

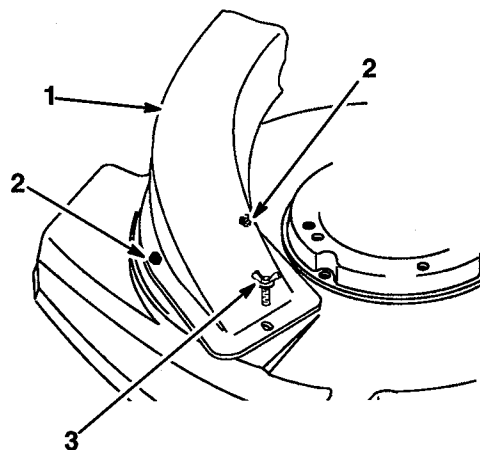

Figure 39

1014

1. Chute assembly
2. Shoulder bolts
3. Wing screw

3. Insert chute support rod through hole at right rear of deck (Fig. 40).

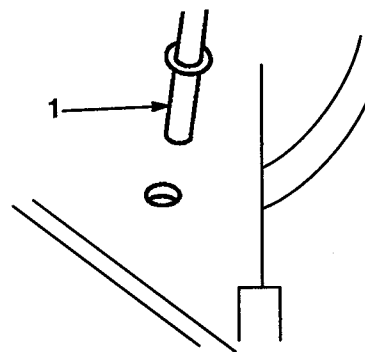
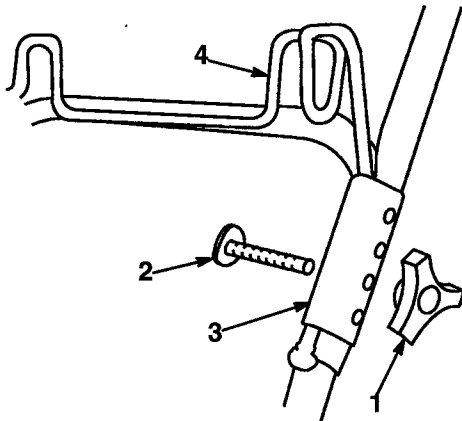

Figure 40

1145

1. Chute support rod
4. Slide chute assembly in a clockwise direction to install or counterclockwise to remove.
5. Secure chute assembly to housing with a wing screw (Fig. 39).

- Remove knob and bolt securing left side upper and lower handle sections (Fig. 41).



1011

Figure 41

- | | |
|---------|-----------------|
| 1. Knob | 3. Hanger clamp |
| 2. Bolt | 4. Bag hanger |

- Hold hanger clamp on outside of handle sections. Insert handle bolt from inside of handle sections through holes in hanger clamp.
- Position bag hanger leg into hanger clamp groove and secure with knob. Repeat steps and assemble clamp and hanger to right side handle sections.
- Close rear of bag by folding sides in and pressing interlocking rear handle halves together (Fig. 42).

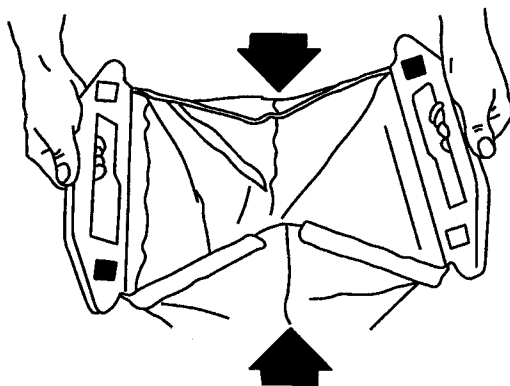

1012

Figure 42

- Position rear bag handles into bag hanger on handle.
- Grasp bag assembly handle and slide over flange of grass chute (Fig. 43). Push downward on handle until it seats into position.

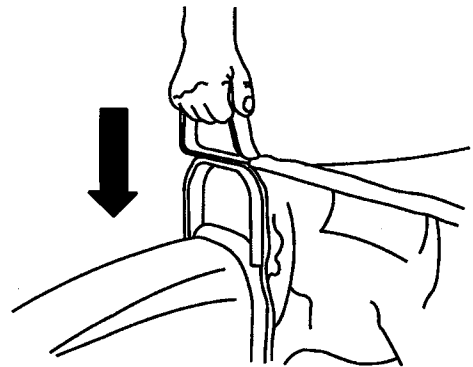

1010

Figure 43

Bag Adjustment

When handle height is changed bag adjustment may be required. A properly adjusted bag should be taut on top cloth area between front bag handle and rear bag hanger handles. If bag is too tight or too loose, adjust as follows:

- Remove bag from rear bag hanger. Remove bolt(s) and knob(s) securing hanger clamps to handle sections (Fig. 44). Hanger clamps have four adjustment holes.

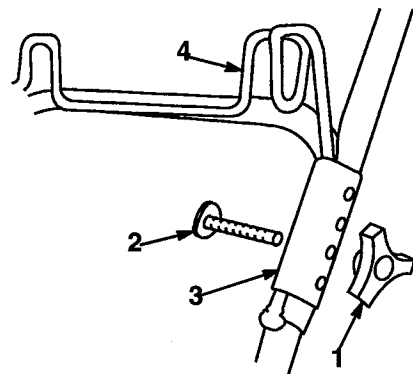

1011

Figure 44

- | | |
|---------|-----------------|
| 1. Knob | 3. Hanger clamp |
| 2. Bolt | 4. Bag hanger |

2. Reassemble hanger clamps to handle sections using whichever set of holes best holds bag taut. Using lower holes in hanger clamps tighten bag assembly and upper holes in hanger clamps loosen bag assembly.

Note: Under normal use, bag materials are subject to deterioration and wear. Check grass bag often and replace when necessary with an original equipment replacement bag. A weakened or inferior bag may let objects pass through, causing injury.

! WARNING

POTENTIAL HAZARD

- Keep hands, sticks or other objects out of grass chute while blade is turning.

WHAT CAN HAPPEN

- Thrown objects or blade contact can cause serious injury.

HOW TO AVOID THE HAZARD

- Always stop engine when emptying grass bag and disconnect spark plug wire before cleaning a clogged chute, bag tunnel or underside of mower housing.

3. Reconnect spark plug wire.

Mulch Plate

! WARNING

POTENTIAL HAZARD

- An uncovered discharge opening will allow objects to be thrown in operator's or bystander's direction. Also, contact with blade could occur.

WHAT CAN HAPPEN

- Thrown objects or blade contact can cause serious injury.

HOW TO AVOID THE HAZARD

- Never operate mower unless cover plate, mulch plate or grass chute and catcher are installed.

1. Stop engine and disconnect spark plug wire (Fig. 38) before installing or removing mulch plate.
2. Insert mulch plate into housing opening (Fig. 45).

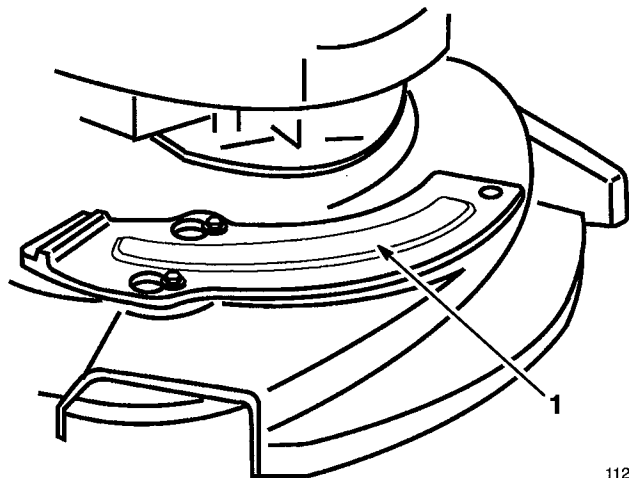

Figure 45

1. Mulch plate

1123

- Two shoulder bolts on the housing protrude through slotted holes in the mulch plate and do not have to be loosened or removed (Fig. 46). Mulch plate moves over the shoulder bolt heads.

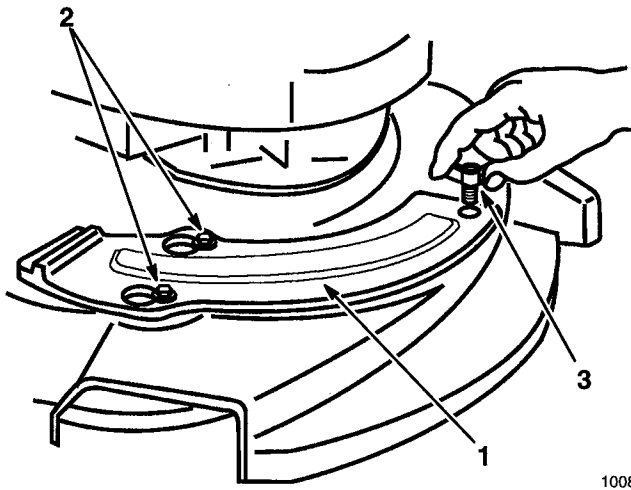



Figure 46

- Mulch plate
- Shoulder bolts
- Wing screw

- Slide mulch plate clockwise to install or counterclockwise to remove.
- Secure with wing screw (Fig. 46).
- Reconnect spark plug wire.

Note: Use only Lawn-Boy original equipment or Lawn-Boy replacement cutting blade. Other blades may strike mulch plate when engine is started and run.

Mulching Operation

Set engine speed control to MULCH ZONE . Full RPM provides the best possible mulching of grass and leaves.

To achieve the best mulching action set mower height of cut so no more than 1/3 of grass stem is cut off; maximum of 1 inch (25 mm) long clippings. If you attempt to mulch more or if grass is very lush, mulching action will be poor. Under these conditions it may be beneficial to use side discharge or catch grass clippings instead of mulching. A few days later a pass with the mulch plate installed will put you back on schedule.

Storage

To prepare lawn mower for off-season storage perform recommended maintenance procedures. See MAINTENANCE section.

Store mower in a cool place.

Fuel

WARNING

POTENTIAL HAZARD

- In certain conditions gasoline is extremely flammable and highly explosive.

WHAT CAN HAPPEN

- A fire or explosion from gasoline can burn you, others, and cause property damage.

HOW TO AVOID THE HAZARD

- Do not store gasoline (fuel) over long periods of time.
- To prevent possible explosion of vaporized fuel, do not store mower with fuel in the tank or carburetor in an enclosure with an open flame. (Example: furnace or water heater pilot light.)
- Allow the engine to cool before storing in any enclosure.

We recommend Lawn-Boy 2 + 4 Fuel Conditioner to stabilize fuel for storage (Fig. 47). If possible, the last fuel fill of the year should be treated with Lawn-Boy 2 + 4 Fuel Conditioner.



Figure 47

1058

Plan ahead and try to run the fuel tank empty when mowing the last time prior to storage. The smaller the amount of fuel in the tank, the shorter the time required to run the fuel system dry. Run mower until engine stops from lack of fuel.

Engine

1. Remove spark plug. Using an oil can, squirt about one tablespoon of oil through spark plug hole (Fig. 48).

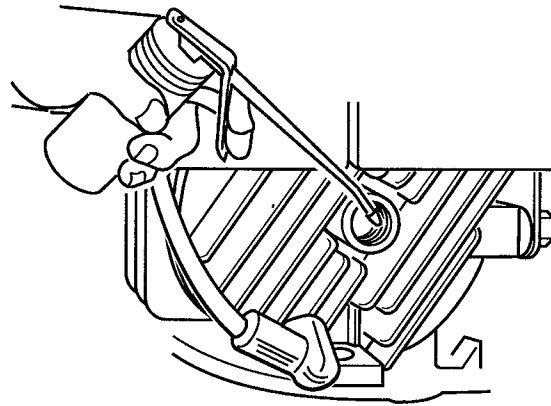

Figure 48

1054

2. Slowly rotate engine several times, using starter rope, to distribute oil (Fig. 49).

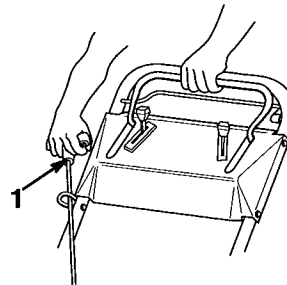

Figure 49

1049

1. Starter rope

3. Replace spark plug but DO NOT connect spark plug wire.

Folding Handle

1. Remove handle mounting hardware from handle brackets (Fig. 50).

Note: Save handle mounting hardware, replace in handle bracket holes.

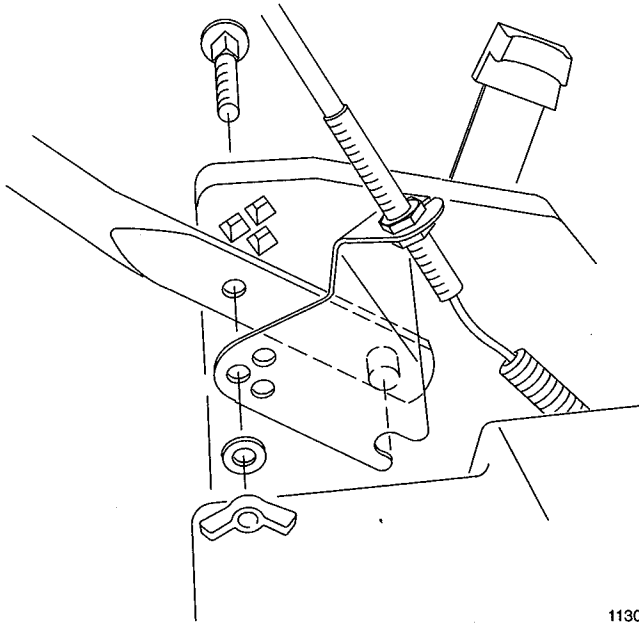

Figure 50

2. Rotate handle toward front of mower (Fig. 51).

Note: Fold handle only as illustrated. If handle is folded in opposite direction damage will occur to control cables.

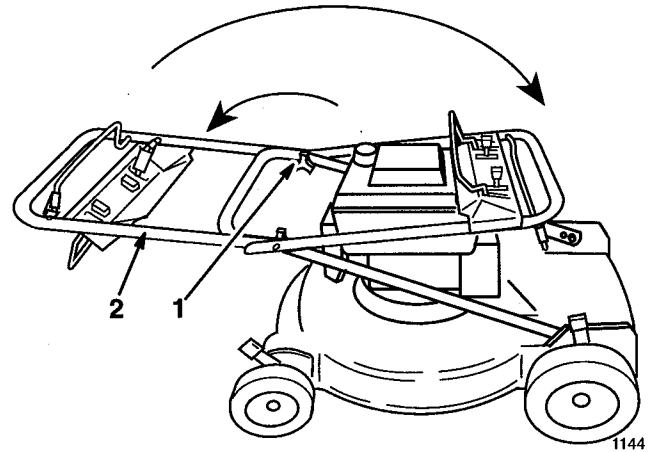

Figure 51

1. Knob
2. Top handle half

3. Loosen knobs securing top handle section to bottom section and fold top handle section back towards rear of mower into storage position.

Removing From Storage

1. Unfold handle. See ASSEMBLY chapter, Handle section.
2. Check and tighten all fasteners.
3. Remove spark plug (Fig. 52) and spin engine rapidly using starter to blow excess oil from the cylinder. Clean spark plug or replace if cracked, broken or electrodes are worn.

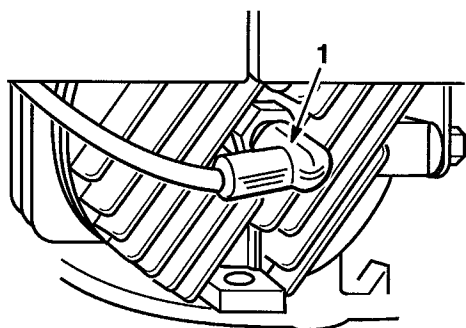

1053

Figure 52

1. Spark plug wire

4. Install spark plug and torque to 180 in.-lbs. (15 ft.-lbs.) (20 N·m).
5. Perform recommended maintenance procedures. See MAINTENANCE section.
6. Fill fuel tank (Fig. 53) with fresh, clean gasoline/oil mix.

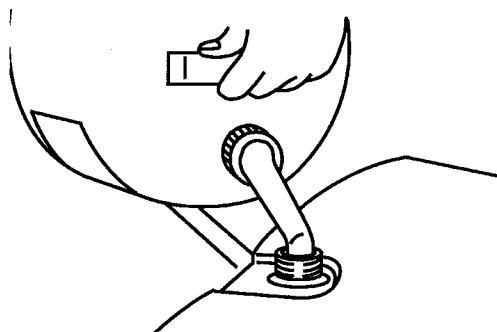

993

Figure 53

7. Reconnect spark plug wire (Fig. 52).

Maintenance Record

Date	Hours Used	Oil Change <small>Doesn't apply to 2-cycle</small>	Air Cleaner Service	Lubrication	Sharpen Blade	Winter Storage	Spring Service	Spark Plug Gap

LAWN-BOY®



Gold Series WPM
Silver Series WPM
Medallion Series WPM

THE LAWN-BOY CONSUMER COVERAGE

WARRANTY

A Full Warranty (Limited Warranty for Commercial Use)

What Is Covered By This Express Warranty?

Lawn-Boy promises to repair any LAWN-BOY Product used for normal residential purposes* if defective in materials or workmanship or if it stops functioning due to the failure of a component. The following time periods apply from the date of purchase:

- Medallion Series Mowers . . . 5 year full warranty
- Gold Series Mowers 4 year full warranty
- Silver Series Mower 2 year full warranty
- Ignition Module 5 years

The cost of parts and labor is included, but the customer pays the transportation costs.

What Products Are Covered By This Warranty?

This warranty applies to all Gold, Silver and Medallion Series Walk Power Mowers. Commercial mowers, M-Series Mowers, riding products and gas trimmers are covered by separate warranty statements.

How About Commercial Use?

LAWN-BOY Consumer Products used for commercial, institutional or rental use are warranted against defects in material or workmanship for 45 days from date of purchase. Components failing due to normal wear are not covered by this warranty.

How Do You Get Warranty Service?

Should you feel your LAWN-BOY Product requires warranty service, contact the dealer who sold you the product or any Authorized LAWN-BOY Service Dealer. The Yellow Pages of your telephone directory is a good reference source. The dealer will either arrange service at his/her dealership or recommend another Authorized Service Dealer who may be more convenient. You may need proof of purchase (copy of registration card, sales receipt, etc.) for warranty validation.

If for any reason you are dissatisfied with the Service Dealer's analysis of the defect in materials or workmanship or if you need a referral to a LAWN-BOY Service Dealer, please feel free to contact us at the following address:

Lawn-Boy Customer Service Department
8111 Lyndale Avenue South
Bloomington, MN 55420-1196
612-888-8801
800-526-6937

What Must You Do To Keep The Warranty In Effect?

You must maintain your LAWN-BOY Product by following the maintenance procedures described in the operator's manual. Such routine maintenance, whether performed by a dealer or by you, is at your expense.

What Does This Warranty Not Cover? and

How Does Your State Law Relate To This Warranty?

There is no other express warranty. This express warranty does not cover:

- Cost of regular maintenance service or parts, such as filters, fuel, lubricants, oil changes, spark plugs, blade sharpening, blade worn out, cable/linkage adjustments or brake and clutch adjustments.
- Any product or part which has been altered or misused or required replacement or repair due to accidents or lack of proper maintenance.
- Repairs necessary due to improper fuel, contaminants in the fuel system, or failure to properly prepare the fuel system prior to any period of non-use over three months.
- Pickup and delivery charges.

All repairs covered by this warranty must be performed by an Authorized LAWN-BOY Service Dealer using Lawn-Boy approved replacement parts.

Repair by an Authorized LAWN-BOY Service Dealer is your sole remedy under this warranty.

Lawn-Boy is not liable for indirect, incidental or consequential damages in connection with the use of the LAWN-BOY Products covered by this warranty, including any cost or expense of providing substitute equipment or service during reasonable periods of malfunction or non-use pending completion of repairs under this warranty. Some states do not allow exclusions of incidental or consequential damages, so the above exclusion may not apply to you.

This warranty gives you specific legal rights, and you may also have other rights which vary from state to state.

* Normal residential purposes means mowing the lawn on the same lot as your home. Use at more than one location is considered commercial use and the commercial use warranty would apply.

COUNTRIES OTHER THAN THE UNITED STATES OR CANADA

Customers who have purchased LAWN-BOY Products exported from the United States or Canada should contact their LAWN-BOY Distributor (Dealer) to obtain guarantee policies for your country, province, or state. If for any reason you are dissatisfied with your Distributor's service or have difficulty obtaining guarantee information, contact the LAWN-BOY importer. If all other remedies fail, you may contact us at Lawn-Boy.