

LAWN-BOY®

Gold Pro Series™

Walk-Behind Mower

Model No. 10548 – 8900001 & Up

Model No. 10547 – 8900001 & Up

Parts Catalog

ORDERING REPLACEMENT PARTS

To order replacement parts, please supply: the part number, the quantity, and the description of each part desired.

Contents

Description	Page	Description	Page
Housing Assembly	1	Short Block Assembly	7
Engine & Blade Assembly	2	Gear Case Assembly	8
Rear Axle Assembly	3	Carburetor Assembly	9
Handle Assembly	4	Lawn-Boy Part Number Index	10-14
Engine Assembly	5	Maintenance	15-17
Engine Assembly (cont.)	6		

Note:

Accessories

Description	Model / Parts No.	Description	Model / Parts No.
Side Bagging Kit	Model No. 89814	Leaf Bag	Model No. 89804
Rear Bagging Kit	Model No. 89800	Leaf Shredder Kit	Model No. 89860

Part Description Abbreviations

Part descriptions in this catalog may include the following abbreviations.

Abbreviation	Meaning	Abbreviation	Meaning
AR	as required	HWHTF	hex washer head thread forming
ASM	assembly	INC	incorporated
CARR	carriage	LH	left hand
DEG	degrees	PH	pan head
FH	flat head	PPH	Phillips pan head
GA	gauge	PTO	power take off
HF	hex flange	RH	right hand
HFV	hex flange washer	SFH	slotted fillister head
HH	hex head	SH	square head
HHF	hex head flange	SHWH	slotted hex washer head
HHST	hex head self tapping	SPH	slotted pan head
HJ	hex jam	STD	standard
HOC	height-of-cut	TAP	self tapping
HS	hex socket	TH	truss head
HSBH	hex socket button head	TTH	Torx truss head
HSFH	hex socket flat head	WH	wing head
HSH	hex socket head		
HWH	hex washer head		

Important Format Explanations

This catalog uses special formats to convey information in illustrations and parts lists. Specifically, one format is used in conjunction with service assemblies and another with quantities associated with reference numbers.

Service Assemblies

Parts within service assemblies have reference numbers in the form $X:Y$. X is the reference number of the service assembly and Y is a sequential number unique to each part within the service assembly.

For example, a wheel assembly might be identified by reference number 6, the tire by 6:1, the valve by 6:2, and the wheel by 6:3. When you order the assembly identified by reference number 6, you receive all parts identified by reference numbers 6:1, 6:2, and 6:3. However, you may also order any part individually.

Reference numbers of this type appear in part lists and as callouts in illustrations.

Reference Numbers with Quantities

Illustrations may have a quantity in parentheses next to a reference number, in the form $X (Y)$. X is the reference number. Y in parentheses is the quantity of the part identified by the reference number.

For example, the illustration callout 4 (2) indicates that two parts are used in that instance.

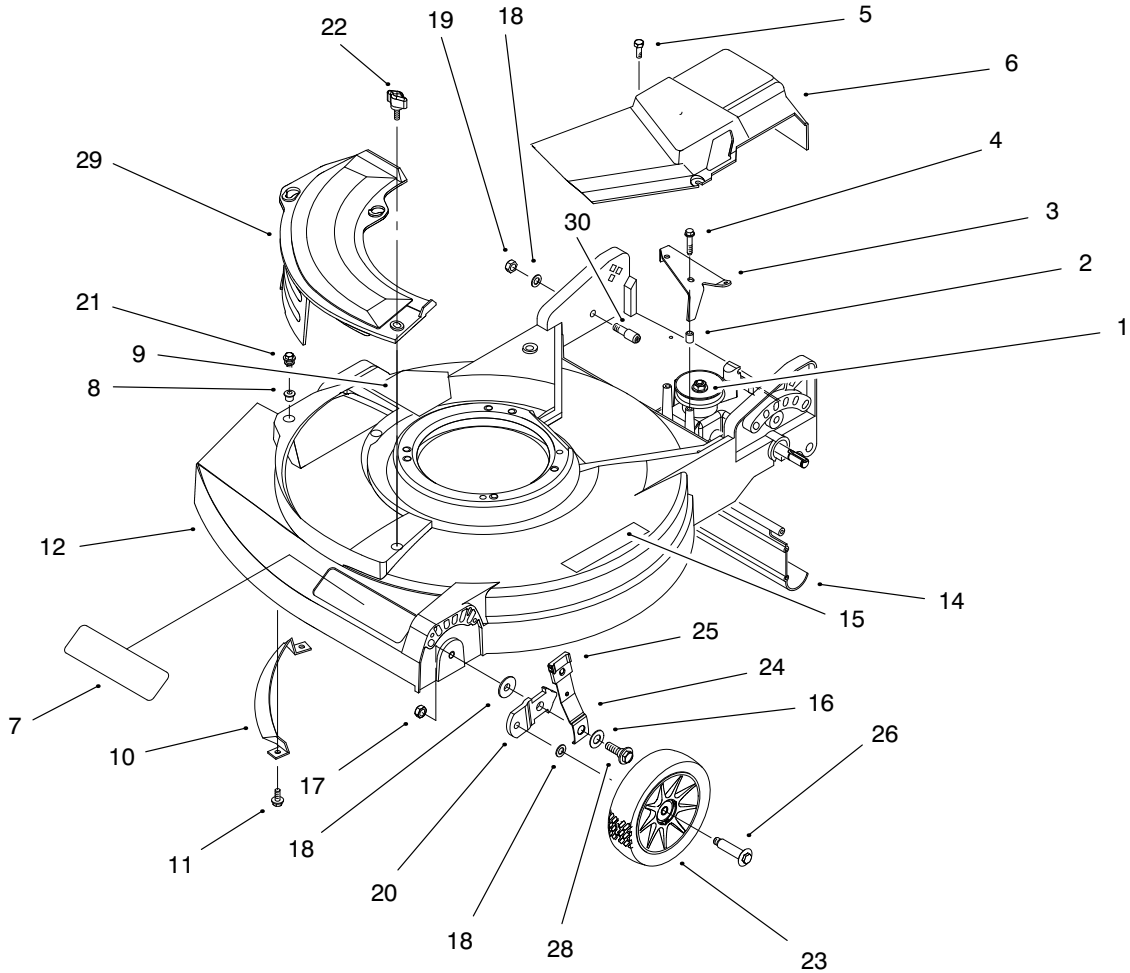

Sheet No.:2

Housing Assembly

Ref. No.	Part No.	Qty.	Description
1	92-7869	1	ASM-Gear Case
2	46-5551	2	Bushing-Spacer
3	92-7699	1	Bracket-Actuator
4	92-7748	2	Screw
5	12-5450	2	Screw-Thread Forming
6	98-4493	1	Cover-Drive
7	95-7421	1	Decal-Deck
8	94-1610	3	Grommet-Plastic
9	39-5770	1	Decal-Danger
10	608175	1	Toe Bar 21
11	46-6811	2	Screw-HWH
12	99-1565	1	Housing
14	92-7736	1	Shield-Trailing
15	93-7250	1	Decal-Warning
16	3290-413	2	Washer-Spring
17	610358	2	Nut-Lock
18	40-1940	4	Washer
19	3296-39	2	Nut-Lock
20	614637	2	Bracket-Wheel Height Adj
21	614677	2	Screw-Sems
22	98-8332	1	Knob-Cover Plate
23	684776	2	ASM-Wheel & Tire 6"
24	92-1006	2	ASM-Spring Arm
25	92-1008	4	Knob-Height Adjust

Ref. No.	Part No.	Qty.	Description
26	92-1099	2	Bolt-Shoulder
28	92-4856	2	Bolt-Shoulder
29	92-8630	1	Mulch Plate-21"
30	92-9673	2	Bolt-Shoulder
*32	95-7052	1	Plate-Chute Opening

* Not illustrated

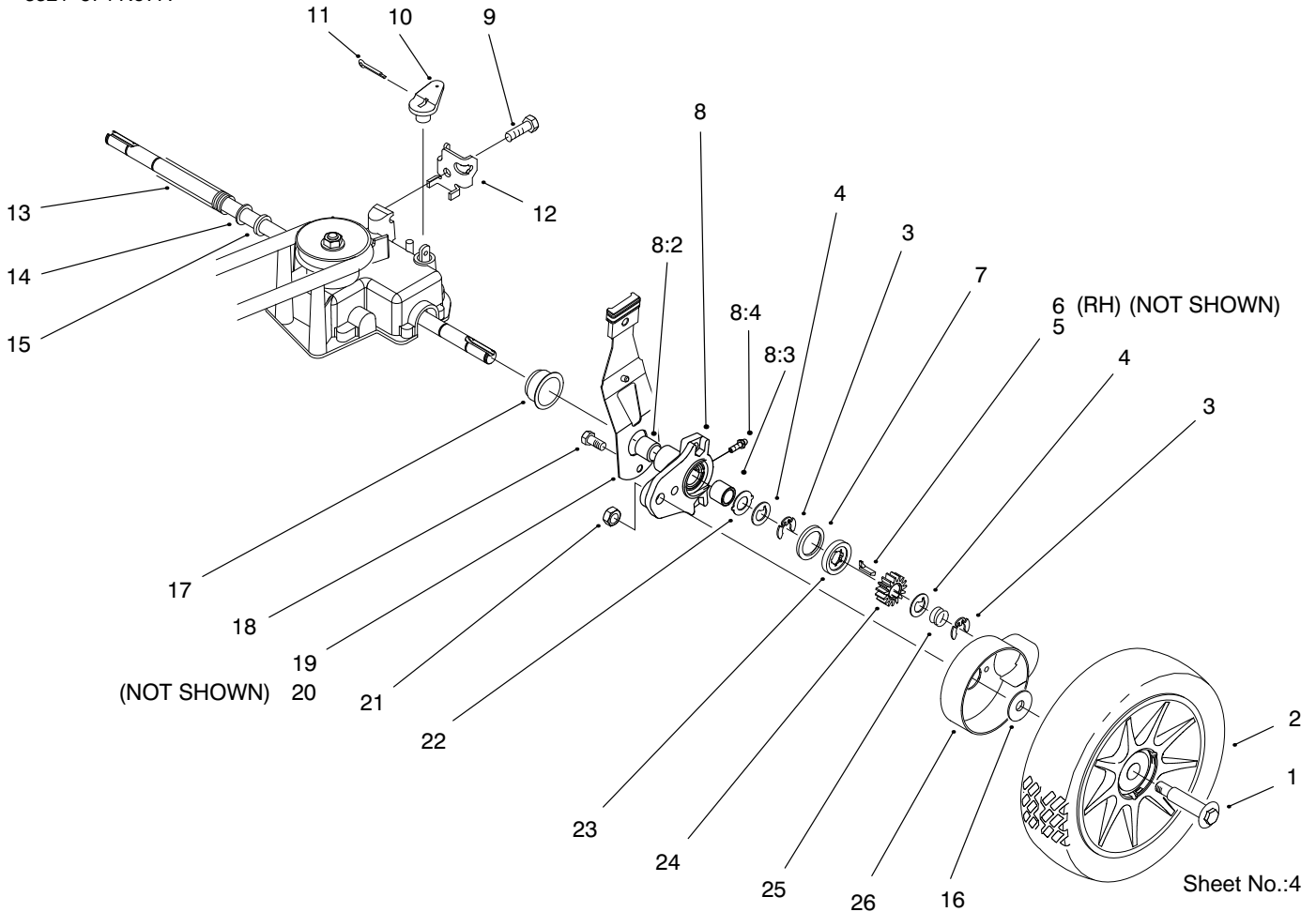

Sheet No.:4

Rear Axle Assembly

Ref. No.	Part No.	Qty.	Description
1	92-1057	2	Bolt-Shoulder
2	92-1042	2	ASM-Whl
3	65-2720	4	Ring-Retaining
4	65-4740	4	Washer-Thrust
5	66-6050	1	Key-Rocking LH
6	66-6040	1	Key-Locking RH
7	65-4710	2	Ring-Friction
8	92-7746	2	ASM-Hgt Adj Arm
8:2	70-9760	2	Bushing
8:3	47-2900	2	Bushing
8:4	302-56	2	Fitting-Grease
9	32144-70	1	Screw-TAP
10	60-8821	1	Lever-Shift
11	3272-10	1	Pin-Cotter
12	82-8780	1	Retainer-Cable
13	24-7920	1	Cover-Drive Shaft
14	303259	1	Washer
15	605255	1	Washer-Flat
16	614426	2	Washer-Stepped
17	92-6535	2	Cap-End
18	32144-85	2	Screw-HH
19	92-6540	1	ASM-Spring Arm
20	92-6539	1	ASM-Spring Arm
21	610358	2	Nut-Lock
22	65-4730	2	Washer-Thrust
23	65-4760	2	Washer

Ref. No.	Part No.	Qty.	Description
24	65-4750	2	Gear-Pinion
25	65-4720	2	Spring-Compression
26	94-1609	2	Cover-Wheel

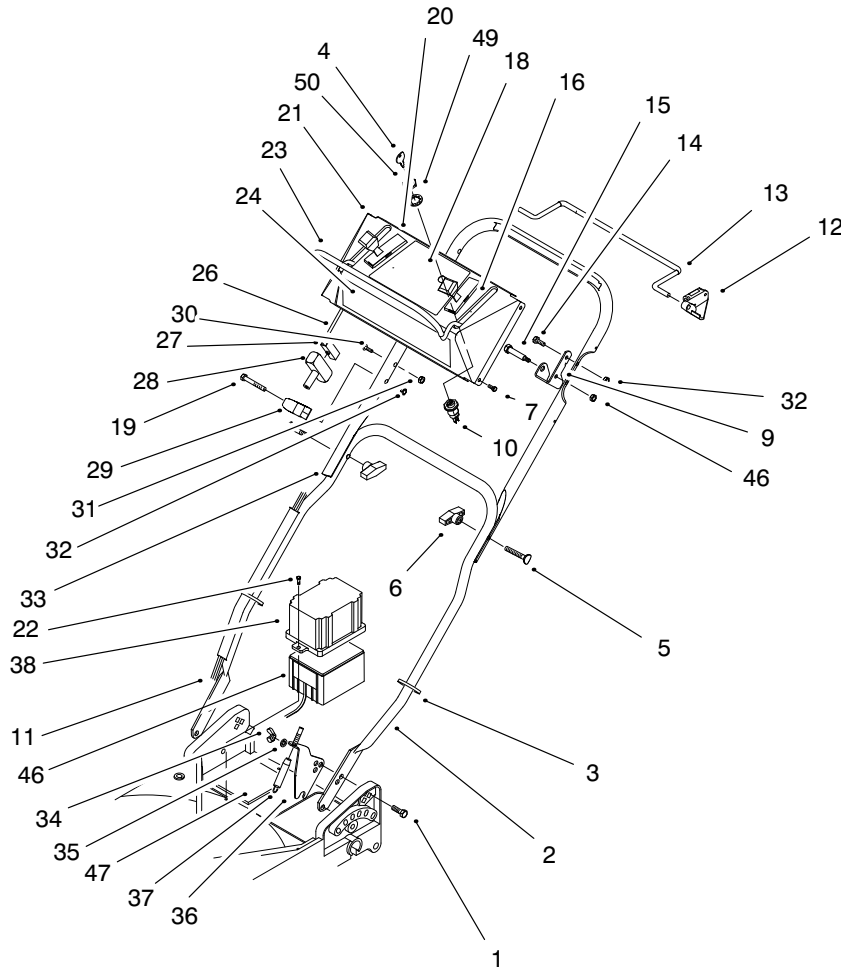

Sheet No.:5

Handle Assembly

Ref. No.	Part No.	Qty.	Description
1	3230-29	2	Bolt-CARR
2	92-6537	1	Handle Section-Lower
3	614249	2	Tie Strap
4	98-4486	1	Key-Ignition
5	614697	2	Screw-Handle
6	98-7134	2	Knob
7	92-9665	4	Screw-Phil
8	3296-56	1	Nut-Lock
9	92-1094	1	Bail Stop Bracket
10	46-5780	1	Switch-Starter
11	94-6059	1	ASM-Wire
12	92-5412	1	Stop-Pivot
13	92-1001	1	Bail-Sp Control
14	321-4	1	Screw-HH
15	613050	1	Bolt
16	95-7410	1	Throttle Cable
18	98-4468	1	Decal-Control Panel
19	321-51	1	Bolt-Hex
20	92-8926	1	Control-Speed
21	99-5200	1	Control- Console
22	12-5450	2	Screw-Thread Forming
23	92-1093	1	Engine Control Bail
24	98-1569	1	Decal-Console
26	95-7438	1	Cable-Control
27	612824	1	Clip-Rope

Ref. No.	Part No.	Qty.	Description
28	612825	1	Handle-Starter
29	93-7383	1	Guide-Rope
30	92-2268	1	Handle Screw
31	92-2928	1	Bracket-Cable Anchor
32	3296-73	3	Nut-Lock
33	92-1092	1	Handle-Upper
34	32103-29	2	Nut-Wing
35	3253-33	2	Washer-Lock
36	92-7899	1	Bracket-Traction Cable
37	92-6518	1	Cable
38	98-4498	1	Case-Battery
46	55-7520	1	Battery Pack
47	612510	1	Pad Battery
48	94-9164	1	Charger-Battery
49	3254-5	1	Washer-Lock
50	218-461	1	Nut-HH (F/W Sw)

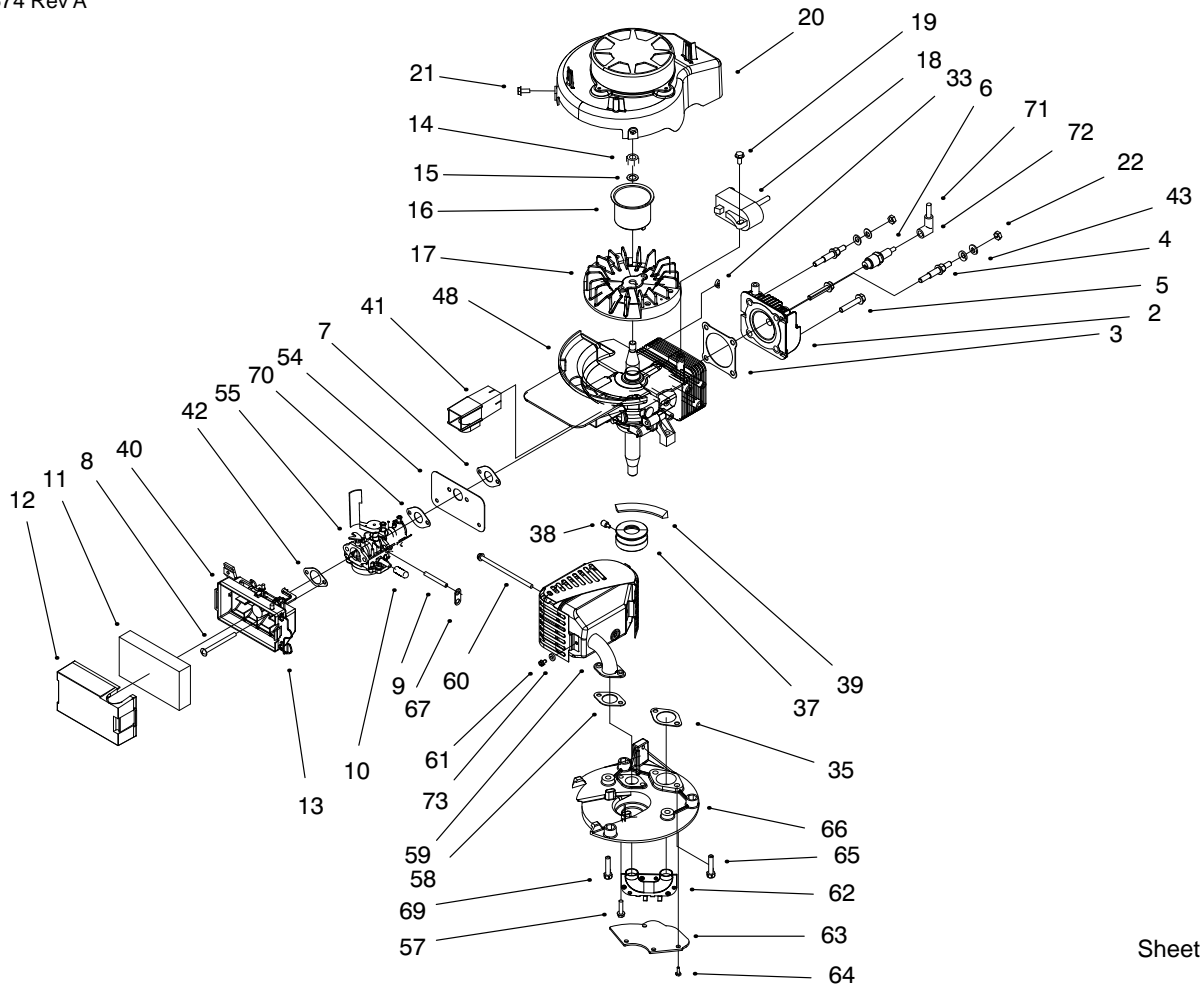

Sheet No.:100

Engine Assembly

Ref. No.	Part No.	Qty.	Description
2	94-5776	1	Head
3	94-5778	1	Gasket-Head
4	94-5779	2	Stud
5	94-5780	2	Bolt
6	50-1170	1	Spark Plug
7	94-5795	2	Intake Gasket
8	612507	2	Screw
9	95-1861	1	Primer Hose
11	95-5574	1	Element-Air Filter
12	95-5577	1	Cover-Air Filter
13	610383	1	Retainer-Filter
14	130743	1	Nut
15	316959	1	Washer-Lock
16	95-1786	1	Cup-Starter
17	95-1882	1	Flywheel Machined Recoil
18	92-1152	1	Ignition ASM
19	613208	2	Screw-HWH
20	95-1880	1	Shroud & Recoil ASM
21	700094	2	Screw
22	146501	2	Nut-Lock
33	607199	1	Key
35	95-1778	1	Gasket-Exhaust
37	95-1878	1	Pulley Engine
38	613227	1	Screw-Set
39	92-1043	1	V-Belt

Ref. No.	Part No.	Qty.	Description
40	95-5588	1	Air Filter Base ASM
41	95-5578	1	Tunnel
42	95-7613	1	Gasket-Filter Base
43	3290-456	4	Washer-Lock
48	95-7637	A/R	Short Block ASM Service
54	98-1388	1	Heat Shield
55	98-7042	1	Carburetor ASM
57	613208	2	Screw-HWH
58	98-1392	1	Gasket
59	99-2904	1	Muffler & Guard
60	611228	1	Bolt
61	98-1394	2	Screw
62	98-1557	1	Transfer Tube
63	98-1591	1	Cover Plate
64	700822	4	Screw
65	322-17	2	Screw-HH
66	98-1563	1	Muffler Plate Machining
67	95-7615	1	Retainer Hose
69	613233	2	Screw-Hhd Washer
70	98-7012	2	Retainer Wire
71	681678	1	High Tension Lead & Cover
72	684698	1	Cover & Terminal
73	3254-1	2	Lockwasher

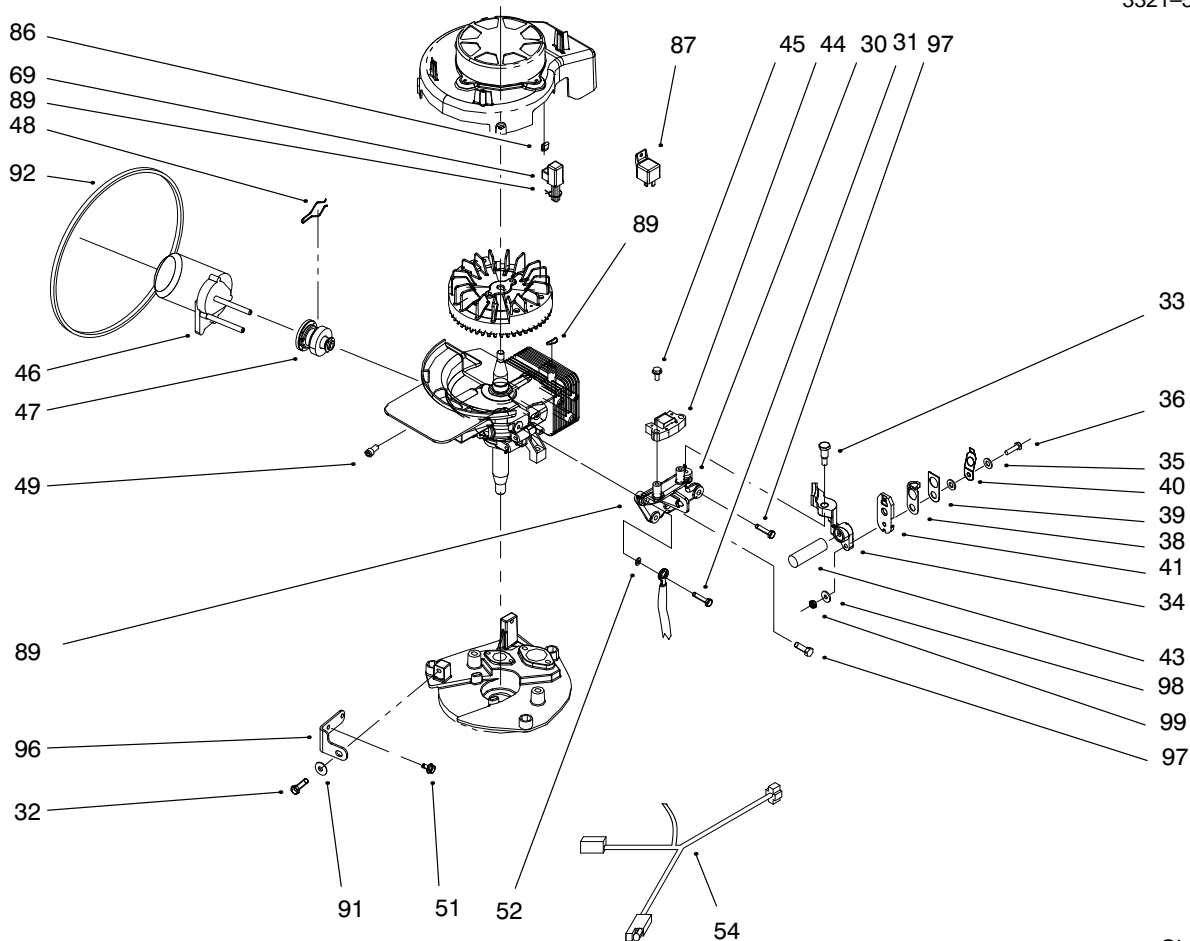

Sheet No.:21

Engine Assembly (cont.)

Ref. No.	Part No.	Qty.	Description
30	95-1884	1	Bracket Alt & Brake Mtg
31	321-7	1	Screw-Cap
32	3234-29	1	Screw-HHF
33	613529	1	Bolt
34	98-7008	1	Assy-Brake w/ Pad
35	306407	2	Washer
36	321-6	1	Screw-HH
38	612841	1	Plate-Contact
39	612842	1	Shield
40	93-1239	1	Spring
41	93-4301	1	ASM-Case
42	95-1886	1	Wire Lead
43	611211	1	Spring-Brake
44	684115	1	Alternator Assembly
45	613208	2	Screw-HWH
46	98-1370	1	ASM-Starter
47	98-1371	1	Pinion-Spring & Clutch
48	613297	1	Spring-Drag
49	611073	1	Screw-Socket Head
51	700094	2	Screw
52	306992	2	Washer-Lock
54	98-1550	1	Wire Harness
68	609790	A/R	Sealer-Loctite
69	684246	1	Cup Assembly

Ref. No.	Part No.	Qty.	Description
86	98-7003	1	Clip
87	116397	1	Relay
89	317893	3	Tie Strap
91	99-2900	1	Washer-Lock
92	3290-379	1	Tie-Cable
96	98-1390	1	Bracket-Elect.
97	322-5	2	Screw-HH
98	3255-7	1	Washer-Lk
99	602315	1	Locknut

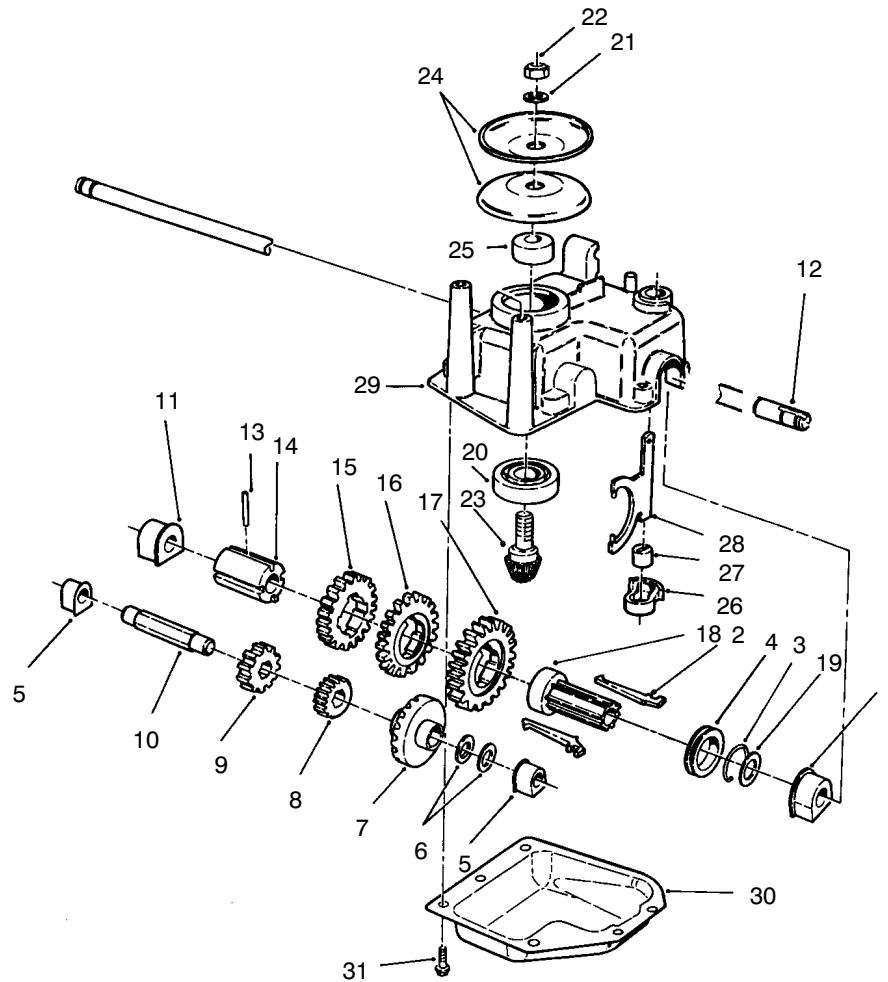

Sheet No.:300

Gear Case Assembly

Ref. No.	Part No.	Qty.	Description	Ref. No.	Part No.	Qty.	Description
2	76-0760	2	Key-Shift	28	60-8870	1	Yoke-Shift
3	65-5250	1	Clip-Spring	29	60-8710	1	Gearcase-Upper 3 Sp
4	76-0770	1	Collar-Shift	30	60-8730	1	Cover-Gearcase
5	60-8750	2	Bushing	31	49-2040	6	Screw-HH
6	36-4791	2	Washer-Thrust				
7	55-3760	1	15 T Pinion				
8	55-3780	1	Pinion 20t 2nd Gear				
9	55-3800	1	Pinion 25t 3rd Gear				
10	60-8800	1	Shaft-Intermediate				
11	60-8850	1	Bushing-Output				
12	65-4770	1	Shaft-Output				
13	3285-19	1	Pin-Spirol				
14	60-8790	1	Sleeve-Gear				
15	55-3810	1	Gear 39t 3rd Gear				
16	55-3790	1	Gear 44t 2nd Gear				
17	55-3770	1	Gear 49t 1st Gear				
18	76-0780	1	Sleeve-Shift Key				
19	36-4780	1	Washer-Thrust				
20	38-7820	1	Bearing-Ball				
21	3256-24	1	Washer-Flat				
22	3296-5	1	Nut-Lock				
23	92-5790	1	Pinion-Bevel				
24	60-8840	2	Pulley-Half				
25	92-5791	1	Spacer-Pulley				
26	60-8810	1	Retainer-Shift-Fork				
27	29-9570	1	Bushing-Yoke				

Lawn-Boy Part Number Index

Part No.	Page No.	Ref. No.	Qty.	Description
116397	6	87	1	Relay
130743	5	14	1	Nut
146501	5	22	2	Nut-Lock
303259	3	14	1	Washer
303712	7	16	2	Ring-Retaining
306407	6	35	2	Washer
306531	2	23	1	Nut-Throttle Cable
306992	6	52	2	Washer-Lock
314576	2	22	1	Screw-Throttle Cable
316959	5	15	1	Washer-Lock
317893	6	89	3	Tie Strap
602315	6	99	1	Locknut
603164	2	1	1	Nut-Blade
605255	3	15	1	Washer-Flat
607199	5	33	1	Key
608175	1	10	1	Toe Bar 21
608850	9	13	4	Screw
609790	7		A/R	Sealant
609790	6	68	A/R	Sealer-Loctite
610358	1	17	2	Nut-Lock
610358	3	21	2	Nut-Lock
610372	7		A/R	Sealant
610383	5	13	1	Retainer-Filter
610834	9	19	1	Collar Adjustment
611073	6	49	1	Screw-Socket Head
611211	6	43	1	Spring-Brake
611213	2	26	1	Retainer
611228	5	60	1	Bolt
611393	7	3	2	Screw
611396	7	4	1	Oil Seal
612383	9	6	1	Washer
612507	5	8	2	Screw
612510	4	47	1	Pad Battery
612543	2	16	1	Blade-21" Whirl
612782	2	4	1	Gas Line
612824	4	27	1	Clip-Rope
612825	4	28	1	Handle-Starter
612841	6	38	1	Plate-Contact
612842	6	39	1	Shield
613050	4	15	1	Bolt
613208	5	19	2	Screw-HWH
613208	5	57	2	Screw-HWH
613208	6	45	2	Screw-HWH
613227	5	38	1	Screw-Set
613233	5	69	2	Screw-Hhd Washer
613297	6	48	1	Spring-Drag
613529	6	33	1	Bolt
614249	4	3	2	Tie Strap
614426	3	16	2	Washer-Stepped
614637	1	20	2	Bracket-Wheel Height Adj
614677	1	21	2	Screw-Sems
614697	4	5	2	Screw-Handle
677525	2	2	1	ASM-Plate & Collar
677982	7	1	2	Liner ASM
681678	5	71	1	High Tension Lead & Cover
683911	7	5	1	Needle Bearing
684115	6	44	1	Alternator Assembly
684246	6	69	1	Cup Assembly
684698	5	72	1	Cover & Terminal
684776	1	23	2	ASM-Wheel & Tire 6"
700094	5	21	2	Screw
700094	6	51	2	Screw

*Not Illustrated

Lawn–Boy Part Number Index (cont.)

Part No.	Page No.	Ref. No.	Qty.	Description
700822	5	64	4	Screw
12–5450	1	5	2	Screw–Thread Forming
12–5450	4	22	2	Screw–Thread Forming
24–7920	3	13	1	Cover–Drive Shaft
29–9570	8	27	1	Bushing–Yoke
36–4780	8	19	1	Washer–Thrust
36–4791	8	6	2	Washer–Thrust
38–7820	8	20	1	Bearing–Ball
39–5770	1	9	1	Decal–Danger
40–1940	1	18	4	Washer
44–2750	2	20	1	Body–Primer
46–5551	1	2	2	Bushing–Spacer
46–5780	4	10	1	Switch–Starter
46–6811	1	11	2	Screw–HWH
47–2480	2	7	1	Rope Stop
47–2900	3	8:3	2	Bushing
49–2040	8	31	6	Screw–HH
50–1170	5	6	1	Spark Plug
55–3760	8	7	1	15 T Pinion
55–3770	8	17	1	Gear 49t 1st Gear
55–3780	8	8	1	Pinion 20t 2nd Gear
55–3790	8	16	1	Gear 44t 2nd Gear
55–3800	8	9	1	Pinion 25t 3rd Gear
55–3810	8	15	1	Gear 39t 3rd Gear
55–7520	4	46	1	Battery Pack
60–8710	8	29	1	Gearcase–Upper 3 Sp
60–8730	8	30	1	Cover–Gearcase
60–8750	8	5	2	Bushing
60–8790	8	14	1	Sleeve–Gear
60–8800	8	10	1	Shaft–Intermediate
60–8810	8	26	1	Retainer–Shift–Fork
60–8821	3	10	1	Lever–Shift
60–8840	8	24	2	Pulley–Half
60–8850	8	11	1	Bushing–Output
60–8870	8	28	1	Yoke–Shift
65–2720	3	3	4	Ring–Retaining
65–4710	3	7	2	Ring–Friction
65–4720	3	25	2	Spring–Compression
65–4730	3	22	2	Washer–Thrust
65–4740	3	4	4	Washer–Thrust
65–4750	3	24	2	Gear–Pinion
65–4760	3	23	2	Washer
65–4770	8	12	1	Shaft–Output
65–5250	8	3	1	Clip–Spring
66–6040	3	6	1	Key–Locking RH
66–6050	3	5	1	Key–Rocking LH
66–7460	2	19	1	Bulb–Primer
70–9760	3	8:2	2	Bushing
76–0760	8	2	2	Key–Shift
76–0770	8	4	1	Collar–Shift
76–0780	8	18	1	Sleeve–Shift Key
82–8780	3	12	1	Retainer–Cable
92–1001	4	13	1	Bail–Sp Control
92–1006	1	24	2	ASM–Spring Arm
92–1008	1	25	4	Knob–Height Adjust
92–1042	3	2	2	ASM–Whl
92–1043	5	39	1	V–Belt
92–1057	3	1	2	Bolt–Shoulder
92–1092	4	33	1	Handle–Upper
92–1093	4	23	1	Engine Control Bail
92–1094	4	9	1	Bail Stop Bracket
92–1099	1	26	2	Bolt–Shoulder

*Not Illustrated

Lawn-Boy Part Number Index (cont.)

Part No.	Page No.	Ref. No.	Qty.	Description
92-1152	5	18	1	Ignition ASM
92-1630	2	17	1	Fan-Mulching
92-2268	4	30	1	Handle Screw
92-2928	4	31	1	Bracket-Cable Anchor
92-4856	1	28	2	Bolt-Shoulder
92-5412	4	12	1	Stop-Pivot
92-5790	8	23	1	Pinion-Bevel
92-5791	8	25	1	Spacer-Pulley
92-6376	9	21	1	Air Vane & Shaft
92-6389	9	14	1	Pin
92-6518	4	37	1	Cable
92-6535	3	17	2	Cap-End
92-6537	4	2	1	Handle Section-Lower
92-6539	3	20	1	ASM-Spring Arm
92-6540	3	19	1	ASM-Spring Arm
92-7699	1	3	1	Bracket-Actuator
92-7736	1	14	1	Shield-Trailing
92-7746	3	8	2	ASM-Hgt Adj Arm
92-7748	1	4	2	Screw
92-7869	1	1	1	ASM-Gear Case
92-7899	4	36	1	Bracket-Traction Cable
92-8615	2	13	1	Applique-Shroud
92-8630	1	29	1	Mulch Plate-21"
92-8926	4	20	1	Control-Speed
92-9665	4	7	4	Screw-Phil
92-9673	1	30	2	Bolt-Shoulder
92-9691	9	12	1	Float Chamber
92-9697	9	16	1	Float & Seat
93-1239	6	40	1	Spring
93-4301	6	41	1	ASM-Case
93-7250	1	15	1	Decal-Warning
93-7383	4	29	1	Guide-Rope
94-1609	3	26	2	Cover-Wheel
94-1610	1	8	3	Grommet-Plastic
94-5764	7	9	1	Oil Seal
94-5765	7	10	1	Ring Retaining
94-5776	5	2	1	Head
94-5778	5	3	1	Gasket-Head
94-5779	5	4	2	Stud
94-5780	5	5	2	Bolt
94-5781	7	14	6	Screw-HWH
94-5787	9	9	1	Filter-Fuel
94-5788	9	2	1	Disc-Choke
94-5795	5	7	2	Intake Gasket
94-6059	4	11	1	ASM-Wire
94-9164	4	48	1	Charger-Battery
95-1778	5	35	1	Gasket-Exhaust
95-1786	5	16	1	Cup-Starter
95-1861	5	9	1	Primer Hose
95-1878	5	37	1	Pulley Engine
95-1880	5	20	1	Shroud & Recoil ASM
95-1882	5	17	1	Flywheel Machined Recoil
95-1884	6	30	1	Bracket Alt & Brake Mtg
95-1886	6	42	1	Wire Lead
95-1897	2	5	1	Gas Tank
95-1899	9	10	1	Float & Arm ASM
95-5574	5	11	1	Element-Air Filter
95-5577	5	12	1	Cover-Air Filter
95-5578	5	41	1	Tunnel
95-5581	9	1	1	Shaft-Choke
95-5583	9	3	1	Spring-Choke Return
95-5588	5	40	1	Air Filter Base ASM

*Not Illustrated

Lawn-Boy Part Number Index (cont.)

Part No.	Page No.	Ref. No.	Qty.	Description
95-7052	1	32	1	Plate-Chute Opening
95-7410	4	16	1	Throttle Cable
95-7420	2	10	1	Decal-Recoil
95-7421	1	7	1	Decal-Deck
95-7438	4	26	1	Cable-Control
95-7613	5	42	1	Gasket-Filter Base
95-7615	5	67	1	Retainer Hose
95-7621	2	9	3	Screw-Tf Acorn Hd
95-7626	7	12	1	Ring Set
95-7628	7	11	1	Piston & Rod ASM
95-7629	7	17	1	Connecting Rod
95-7633	7	6	1	Cylinder & Ccase ASM w/S
95-7637	5	48	A/R	Short Block ASM Service
98-1357	9	8	1	Mainjet 77.5
98-1362	9	11	1	Gasket-Float Chamber
98-1370	6	46	1	ASM-Starter
98-1371	6	47	1	Pinion-Spring & Clutch
98-1386	2	24	1	Foam Pad
98-1388	5	54	1	Heat Shield
98-1390	6	96	1	Bracket-Elect.
98-1392	5	58	1	Gasket
98-1394	5	61	2	Screw
98-1550	6	54	1	Wire Harness
98-1557	5	62	1	Transfer Tube
98-1563	5	66	1	Muffler Plate Machining
98-1569	4	24	1	Decal-Console
98-1591	5	63	1	Cover Plate
98-4468	4	18	1	Decal-Control Panel
98-4480	2	3	3	Screw-Sems
98-4486	4	4	1	Key-Ignition
98-4493	1	6	1	Cover-Drive
98-4498	4	38	1	Case-Battery
98-7001	9	7	1	Nozzle
98-7003	6	86	1	Clip
98-7008	6	34	1	Assy-Brake w/ Pad
98-7011	9	18	1	Spring-Throttle
98-7012	5	70	2	Retainer Wire
98-7042	9	4	1	Carb w/Gaskets
98-7042	5	55	1	Carburetor ASM
98-7046	7	15	1	Ring-Retaining
98-7047	9	20	1	Disc-Throttle
98-7134	4	6	2	Knob
98-8332	1	22	1	Knob-Cover Plate
98-8344	2	6	1	ASM-Fuel/Oil Cap
98-8346	2	12	1	ASM-Shroud Electric
99-1521	2	27	1	Foam Strip
99-1522	2	28	2	Foam Strip
99-1565	1	12	1	Housing
99-2900	6	91	1	Washer-Lock
99-2904	5	59	1	Muffler & Guard
99-2920	7	7	1	Crankshaft & Bearing ASM
99-5200	4	21	1	Control- Console
218-461	4	50	1	Nut-HH (F/W Sw)
302-56	3	8:4	2	Fitting-Grease
321-4	4	14	1	Screw-HH
321-6	6	36	1	Screw-HH
321-7	6	31	1	Screw-Cap
321-51	4	19	1	Bolt-Hex
322-5	6	97	2	Screw-HH
322-17	5	65	2	Screw-HH
3230-29	4	1	2	Bolt-CARR
3234-29	6	32	1	Screw-HHF

*Not Illustrated

Lawn-Boy Part Number Index (cont.)

Part No.	Page No.	Ref. No.	Qty.	Description
3253-33	4	35	2	Washer-Lock
3254-1	5	73	2	Lockwasher
3254-5	4	49	1	Washer-Lock
3255-7	6	98	1	Washer-Lk
3256-24	8	21	1	Washer-Flat
3272-10	3	11	1	Pin-Cotter
3285-19	8	13	1	Pin-Spirol
3290-379	6	92	1	Tie-Cable
3290-413	1	16	2	Washer-Spring
3290-443	2	8	1	Staple
3290-456	5	43	4	Washer-Lock
3296-5	8	22	1	Nut-Lock
3296-39	1	19	2	Nut-Lock
3296-56	4	8	1	Nut-Lock
3296-73	4	32	3	Nut-Lock
32103-29	4	34	2	Nut-Wing
32144-70	3	9	1	Screw-TAP
32144-85	3	18	2	Screw-HH

