

# **LAWN-BOY®**

## **Silver Series®**

### **Walk-Behind Mower**

**Model No. 10330 – 8900001 & Up**

---

## **Parts Catalog**

## ORDERING REPLACEMENT PARTS

To order replacement parts, please supply: the part number, the quantity, and the description of each part desired.

## Contents

Description	Page	Description	Page
Mulch Plate & Wheel Assembly .....	1	Engine LEV100-345001B .....	8-10
Housing Assembly .....	2	Recoil Starter Assembly 590694 .....	11
Engine & Blade Assembly .....	3	Recoil Starter Assembly 590737 (Optional) ....	12
Rear Axle Assembly .....	4	Lawn-Boy Part Number Index .....	13-14
Handle Assembly .....	5	Maintenance .....	15-17
Gear Case Assembly .....	6		
Carburetor No. 640118 .....	7	<b>Note:</b>	

## Accessories

Description	Model / Parts No.	Description	Model / Parts No.
Rear Bagging Kit .....	Model No. 89800	Mow & Feed	
Side Bagging Kit .....	Model No. 89814	Fertilizer Spreader .....	Model No. 52070
Leaf Bag .....	Model No. 89804	Mulch Plate .....	Model No. 89864
Leaf Shredder Kit .....	Model No. 89860		
Leaf Bag Kit w/Chute .....	Model No. 89811		

## Part Description Abbreviations

Part descriptions in this catalog may include the following abbreviations.

Abbreviation	Meaning	Abbreviation	Meaning
AR .....	as required	HWHTF .....	hex washer head
ASM .....	assembly		thread forming
CARR .....	carriage	INC .....	incorporated
DEG .....	degrees	LH .....	left hand
FH .....	flat head	PH .....	pan head
GA .....	gauge	PPH .....	Phillips pan head
HF .....	hex flange	PTO .....	power take off
HFW .....	hex flange washer	RH .....	right hand
HH .....	hex head	SFH .....	slotted fillister head
HHF .....	hex head flange	SH .....	square head
HHST .....	hex head self tapping	SHWH .....	slotted hex washer head
HJ .....	hex jam	SPH .....	slotted pan head
HOC .....	height-of-cut	STD .....	standard
HS .....	hex socket	TAP .....	self tapping
HSBH .....	hex socket button head	TH .....	truss head
HSFH .....	hex socket flat head	TTH .....	Torx truss head
HSH .....	hex socket head	WH .....	wing head
HWH .....	hex washer head		

# Important Format Explanations

This catalog uses special formats to convey information in illustrations and parts lists. Specifically, one format is used in conjunction with service assemblies and another with quantities associated with reference numbers.

## Service Assemblies

Parts within service assemblies have reference numbers in the form  $X:Y$ .  $X$  is the reference number of the service assembly and  $Y$  is a sequential number unique to each part within the service assembly.

For example, a wheel assembly might be identified by reference number 6, the tire by 6:1, the valve by 6:2, and the wheel by 6:3. When you order the assembly identified by reference number 6, you receive all parts identified by reference numbers 6:1, 6:2, and 6:3. However, you may also order any part individually.

Reference numbers of this type appear in part lists and as callouts in illustrations.

## Reference Numbers with Quantities

Illustrations may have a quantity in parentheses next to a reference number, in the form  $X (Y)$ .  $X$  is the reference number.  $Y$  in parentheses is the quantity of the part identified by the reference number.

For example, the illustration callout 4 (2) indicates that two parts are used in that instance.















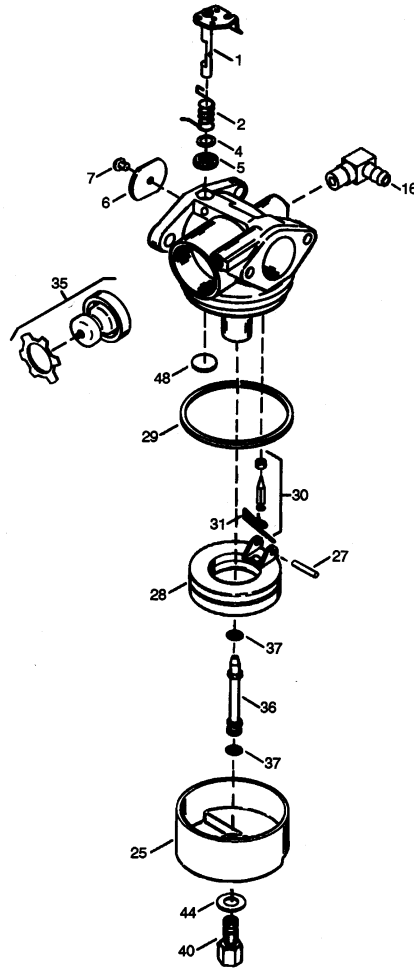

## CARBURETOR No. 640118

Ref. No.	Part No.	Description	No. Used	Ref. No.	Part No.	Description	No. Used
0	640118	Carburetor	1	29	631028	Float Bowl "O" Ring	1
1	631615	Throttle Shaft & Lever Assembly	1	30	631021	Inlet Needle, Seat, & Clip (Incl. 31)	1
2	631767	Throttle Return Spring	1	31	631022	Spring Clip	1
4	631184	Dust Seal Washer	1	35	36045A	Primer Bulb/Retainer Ring	1
5	631183	Dust Seal (Throttle)	1	36	632735	Main Nozzle Tube	1
6	632504	Throttle Shutter	1	37	632547	O-Ring, Main Nozzle Tube	2
7	650506	Shutter Screw	1	40	632743	High Speed Bowl Nut	1
16	631807	Fuel Fitting	1	44	27110	Bowl Nut Washer	1
25	631867	Float Bowl	1	48	631027	Welch Plug, Atmospheric Vent	1
27	631024	Float Shaft	1				
28	632019	Float	1				



**ENGINE LEV100-345001B**

Ref. No.	Part No.	Description	No. Used	Ref. No.	Part No.	Description	No. Used
1	37027	Cylinder (Incl. 2 & 20)	1	125	36780	Exhaust Valve (1/32" OS) (Incl. 151)	1
2	26727	Dowel Pin	2	126	36781	Intake Valve (Std.) (Incl. 151)	1
6	33734	Breather Element	1	126	36782	Intake Valve (1/32" OS) (Incl. 151)	1
7	36557	Breather Body Ass'y. (Incl. 6 & 12A)	1	130	6021A	Screw	6
12A	36558	Breather Cover & Tube (Incl. 12B)	1	135	35395	Resistor Spark Plug (RJ19LM)	1
14	28277	Washer	1	150	35991	Valve Spring	2
15	30589	Governor Rod (Incl. 14)	1	151	31673	Valve Spring Cap	2
16	34839A	Governor Lever	1	151A	40017	Intake Valve Seal	1
17	31335	Governor Lever Clamp	1	169	36783	Valve Cover Gasket	1
18	651018	Screw	1	172	36784	Valve Cover	1
19	36281	Extension Spring	1	174	30200	Screw	2
20	32600	Oil Seal	1	178	29752	Nut & Lock Washer	2
30	37124	Crankshaft	1	182	6201	Screw	2
40	35544A	Piston, Pin & Ring Set (Std.)	1	184	26756	Carburetor To Intake Pipe Gasket	1
40	33545A	Piston, Pin & Ring Set (.010" OS)	1	185	36785	Intake Pipe	1
40	35546	Piston, Pin & Ring Set (.020" OS)	1	186	32653	Governor Link	1
41	35541	Piston & Pin Ass'y. (Std.) (Incl. 43)	1	189	650839	Screw	2
41	35542	Piston & Pin Ass'y. (.010" OS) (Incl. 43)	1	191	36559	S.E. Brake Bracket (Incl. 195)	1
41	35543	Piston & Pin Ass'y. (.020" OS) (Incl. 43)	1	195	610973	Terminal	1
42	35547A	Ring Set (Std.)	1	207	34336	Throttle Link	1
42	35548A	Ring Set (.010" OS)	1	216	33086	R.P.M. Adjusting Lever	1
42	35549	Ring Set (.020" OS)	1	223	650451	Screw	2
43	20381	Piston Pin Retaining Ring	2	224	36786	Intake Pipe Gasket	1
45	36777	Connecting Rod Ass'y. (Incl. 46)	1	238	650806	Screw	2
46	32610A	Connecting Rod Bolt	2	239	34338	Air Cleaner Gasket	1
48	27241	Valve Lifter	2	240	37115	Air Cleaner Body	1
50	37032	Camshaft (MCR)	1	245	37116	Air Cleaner Filter	1
52	29914	Oil Pump Ass'y.	1	245A	37117	Air Cleaner Filter	1
69	35261	Mounting Flange Gasket	1	250	37118	Air Cleaner Cover	1
70	36995	Mounting Flange (Incl. 72 thru 83)	1	260	37125	Blower Housing	1
72	36083	Oil Drain Plug	1	261	30200	Screw	2
75	27897	Oil Seal	1	262	650831	Screw	2
80	30574A	Governor Shaft	1	263A	36758	Starter Grill	1
81	30590A	Washer	1	275	36790	Muffler	1
82	30591	Governor Gear Ass'y. (Incl. 81)	1	277	650988	Screw	2
83	30588A	Governor Spool	1	285	35000A	Starter Cup	1
86	650488	Screw	6	287	650926	Screw	2
89	611004	Flywheel Key	1	290	34357	Fuel Line	1
90	611112	Flywheel	1	292	26460	Fuel Line Clamp	2
92	650815	Belleville Washer	1	300	35586	Fuel Tank (Incl. 292 & 301)	1
93	650816	Flywheel Nut	1	301	36246	Fuel Cap	1
100	34443B	Solid State Ignition	1	305	35577	Oil Fill Tube	1
101	610118	Spark Plug Cover	1	306	36996	"O" - Ring	1
103	651007	Screw, Torx T-15,	2	307	35499	"O" - Ring	1
110	37047	Ground Wire	1	309	650562	Screw	1
119	37028	Cylinder Head Gasket	1	310	36801	Dipstick	1
120	36788	Cylinder Head	1	313	34080	Spacer	1
125	36779	Exhaust Valve (Std.) (Incl. 151)	1	370A	36261	Lubrication Decal	1
				380	640118	Carburetor (Incl. 184)	1

**ENGINE LEV100-345001B**

Ref. No.	Part No.	Description	No. Used
390	590694	Rewind Starter (NOTE: This engine could have been built with 590737 starter.	1
400	37029	Gasket Set (Incl. Items Marked PK in Notes) Incl. part #'s 26756 (1), 28833 (1) 34338 (1), 35261 (1), 36783 (1), 36786 (1) 36832 (1), 37128 (1).	1
416	36085	Spark Arrestor Kit (Incl. 417) (Optional)	1
417	650760	Screw (Optional)	1
420	730225	SAE 30 4-Cycle Engine Oil (Quart)	1

Ref. No.	Part No.	Description	No. Used

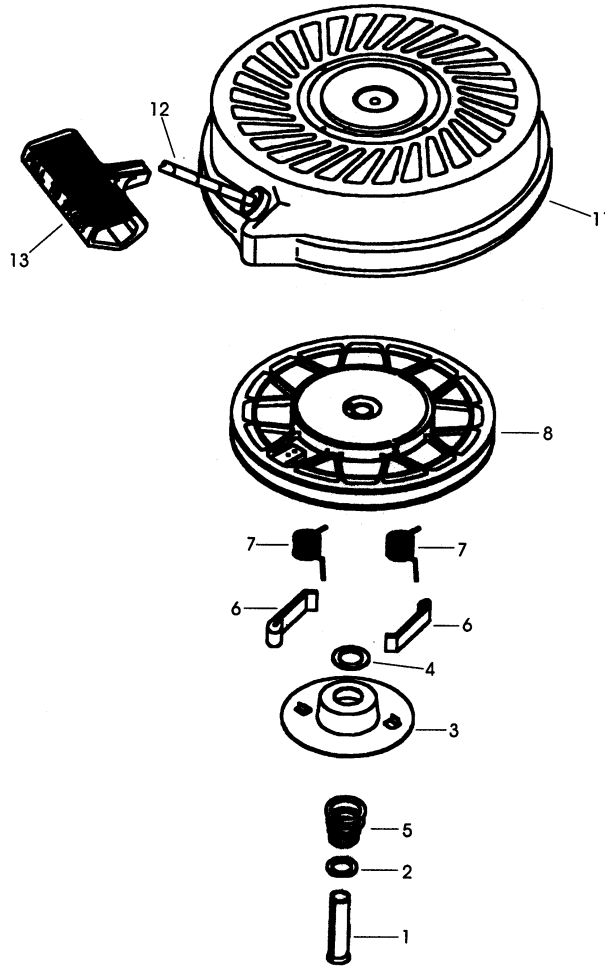

## RECOIL STARTER ASSEMBLY 590694

Ref. No.	Part No.	Description	No. Used
0	590694	Recoil Starter	1
1	590599A	Spring Pin (Incl. 4)	1
2	590600	Washer	1
3	590696	Retainer	1
4	590601	Washer	2
5	590697	Brake Spring	1
6	590698	Starter Dog	2
7	590699	Dog Spring	2

Ref. No.	Part No.	Description	No. Used
8	590700	Pulley & Rewind Spring Ass'y.	1
11	590695	Starter Housing Ass'y (40 degree grommet)	1
12	590535	Starter Rope (98" X 9/64" dia.)	1
13	590701	Starter Handle	1

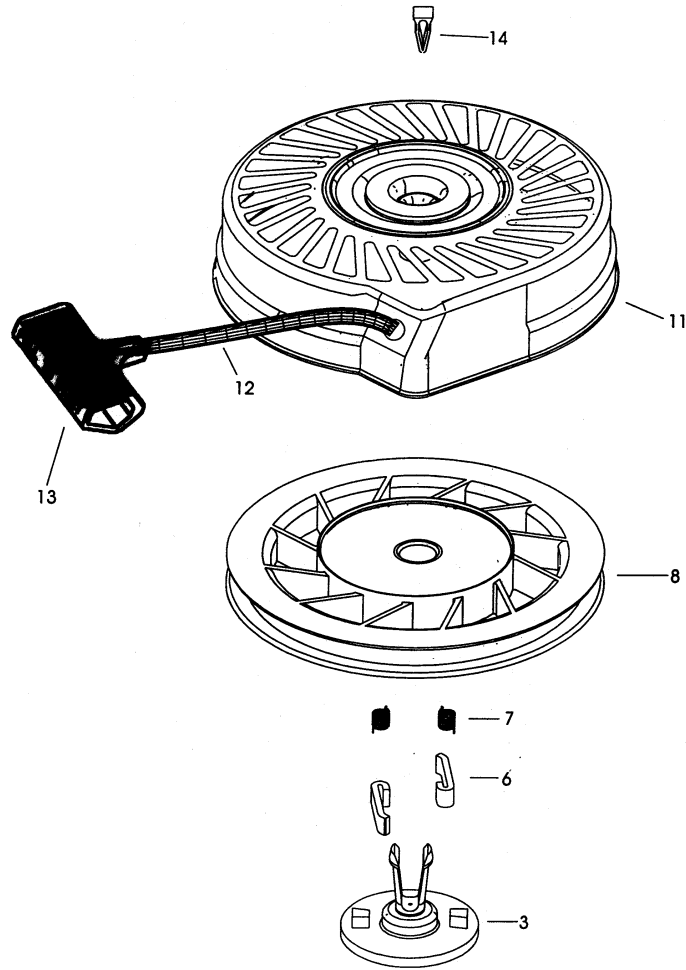

### RECOIL STARTER ASSEMBLY 590737 (Optional)

Ref. No.	Part No.	Description	No. Used	Ref. No.	Part No.	Description	No. Used
0	590737	Rewind Starter	1	11	590637A	Starter Housing Ass'y (40 degree grommet)	1
3	590740	Retainer	1	12	590535	Starter Rope (Length 98" x 9/64" dia.)	1
6	590616	Starter Dog	2	13	590701	Starter Handle	1
7	590617	Dog Spring	2	14	590741	Locking Tab	1
8	590618A	Pulley & Rewind Spring Ass'y	1				

# Lawn-Boy Part Number Index

Part No.	Page No.	Ref. No.	Qty.	Description
603164	3	18	1	Nut-Blade
605120	2	5	1	Grommet
610358	4	13	2	Nut-Lock
612543	3	17	1	Blade-21" Whirl
613227	3	16	1	Screw-Set
613765	1	11	1	Nut-Cage
614249	5	33	4	Tie Strap
614426	4	19	2	Washer-Stepped
614447	4	9	2	Spacer-Axle Shaft
614596	6	5	1	Gear-34t
614643	5	19	1	Handle Section-Lower
614668	6	1	1	Cover-Gear Case
614669	6	17	2	Pulley-Half
614672	1	4	4	Bolt-Shoulder
614677	1	9	2	Screw-Sems
614687	1	3	2	Spring Arm-Front
614696	6	8	1	Shaft-Intermediate
614697	5	2	2	Screw-Handle
677525	3	1	1	ASM-Plate & Collar
684776	1	6	2	ASM-Wheel & Tire 6"
36-4780	6	6	2	Washer-Thrust
36-4791	6	11	2	Washer-Thrust
38-7820	6	13	1	Bearing-Ball
39-5770	2	15	1	Decal-Danger
40-1940	1	18	2	Washer
47-2900	4	8:3	2	Bushing
55-3760	6	10	1	15 T Pinion
60-8750	6	12	2	Bushing
60-8850	6	3	2	Bushing-Output
60-8890	6	15	1	Gear-Pinion
62-6660	6	18	1	Spacer-Pulley
65-2690	3	14	1	Decal-Hot Surface
65-2720	4	3	4	Ring-Retaining
65-4710	4	7	2	Ring-Friction
65-4720	4	17	2	Spring-Compression
65-4730	4	14	2	Washer-Thrust
65-4740	4	4	4	Washer-Thrust
65-4750	4	16	2	Gear-Pinion
65-4760	4	15	2	Washer
65-5221	2	7	2	Screw-Thread Forming
66-6040	4	6	1	Key-Locking RH
66-6050	4	5	1	Key-Rocking LH
70-9760	4	8:2	2	Bushing
92-1001	5	9	1	Bail-Sp Control
92-1004	4	12	2	ASM-Spring Arm
92-1008	1	2	4	Knob-Height Adjust
92-1024	3	4	1	Guide-Belt
92-1042	4	2	2	ASM-Whl
92-1057	4	1	2	Bolt-Shoulder
92-1097	2	16	1	Decal-Discharge
92-1099	1	5	2	Bolt-Shoulder
92-1701	3	7	1	Rope-Stop
92-2266	5	5	1	Screw-Handle
92-2914	2	2	1	Decal-HOC
92-2915	2	1	1	Decal-HOC
92-4853	5	14	1	Handle-Starter
92-4881	1	14	2	Plate-Height Adjust
92-4890	1	15	2	Washer
92-5412	5	8	1	Stop-Pivot
92-5424	5	17	1	Staple-Handle
92-7723	2	12	1	ASM-Handle Bracket

\*Not Illustrated



# Lawn-Boy Part Number Index

Part No.	Page No.	Ref. No.	Qty.	Description
92-7724	2	3	1	ASM-Handle Bracket
92-7726	5	7	1	Cable-Traction
92-7727	6	2	1	Gearcase-Upper Ss
92-7728	2	6	1	Guide-Transmission
92-7729	5	6	1	Anchor-Cable
92-7731	1	16	2	Plate-Baffle
92-7735	2	4	1	ASM-Gear Case
92-7746	4	8	2	ASM-Hgt Adj Arm
92-8630	1	8	1	Mulch Plate-21"
92-8647	2	14	1	Shield-Trailing
92-9575	3	2	1	Pulley-Engine
92-9665	2	8	1	Screw-Phil
93-0239	6	7	1	Shaft-Output
93-3653	5	11	1	Handle-Guard
93-4184	5	12	1	Bail-Flywheel Brake
93-4196	3	10	1	Shield-Grass
93-7250	2	10	1	Decal-Warning
93-7380	5	20	1	Anchor-Cable
93-7381	4	10	1	V-Belt
93-7383	5	16	1	Guide-Rope
94-1609	4	18	2	Cover-Wheel
94-1610	1	10	2	Grommet-Plastic
94-6066	3	15	1	Guard-Muffler
95-1713	5	13	1	Handle Section-Upper
95-1726	3	3	3	Screw-Engine Mount
95-7052	1	19	1	Plate-Cover
95-7068	2	9	1	Cover-Drive
95-7403	1	17	2	Bracket-Wheel Height Adj
95-7448	3	8	1	Decal-Shroud Top
98-1560	5	18	1	ASM-Brake Cable
98-1567	3	11	1	Decal-Deck
98-1593	3	5	1	Applique
98-4477	2	17	1	ASM-Housing & Baffle
98-7134	5	3	2	Knob
98-8332	1	7	1	Knob-Cover Plate
302-56	4	8:4	2	Fitting-Grease
321-50	5	15	1	Screw
322-3	2	13	6	Screw-HH
3256-1	5	10	1	Washer-Flat
3256-24	6	14	1	Washer-Flat
3285-19	6	4	2	Pin-Spirol
3296-5	6	16	1	Nut-Lock
3296-29	2	18	6	Nut-Lock
3296-73	5	4	2	Nut-Lock
32144-4	6	9	4	Screw-TAP
32144-85	3	13	1	Screw-HH
32144-85	4	11	2	Screw-HH

\*Not Illustrated





